

PRODUCT INFORMATION PACKET

marathon[®]
Motors

Model No: 215TTFBD6028
Catalog No: GT1219A
10,1800,TEFC,215TC,3/60/230/460
Totally Enclosed Fan Cooled (TEFC)



Regal and Marathon are trademarks of Regal Beloit Corporation or one of its affiliated companies.
©2018 Regal Beloit Corporation, All Rights Reserved. MC017097E

REGAL[®]



Nameplate Specifications

Output HP	10 Hp	Output KW	7.5 kW
Frequency	60 Hz	Voltage	230/460 V
Current	25.0/12.5 A	Speed	1762 rpm
Service Factor	1.15	Phase	3
Efficiency	92.1 %	Duty	Continuous
Insulation Class	F	Design Code	B
KVA Code	H	Frame	215TC
Enclosure	Totally Enclosed Fan Cooled	Overload Protector	No
Ambient Temperature	40 °C	Drive End Bearing Size	6307
Opp Drive End Bearing Size	6206	UL	Recognized
CSA	Y	CE	Y
IP Code	43		

Technical Specifications

Electrical Type	Squirrel Cage Inverter Rated	Starting Method	Line Or Inverter
Poles	4	Rotation	Reversible
Mounting	Rigid base	Motor Orientation	Horizontal
Drive End Bearing	Ball	Opp Drive End Bearing	Ball
Frame Material	Rolled Steel	Shaft Type	T
Frame Length	21.26 in	Shaft Diameter	1.375 in
Shaft Extension	3.38 in	Assembly/Box Mounting	F1/F2 Capable
Outline Drawing	B-SS620688	Connection Diagram	A-EE7308

This is an uncontrolled document once printed or downloaded and is subject to change without notice. Date Created: 07/02/2018

Uncontrolled Copy

SS620688

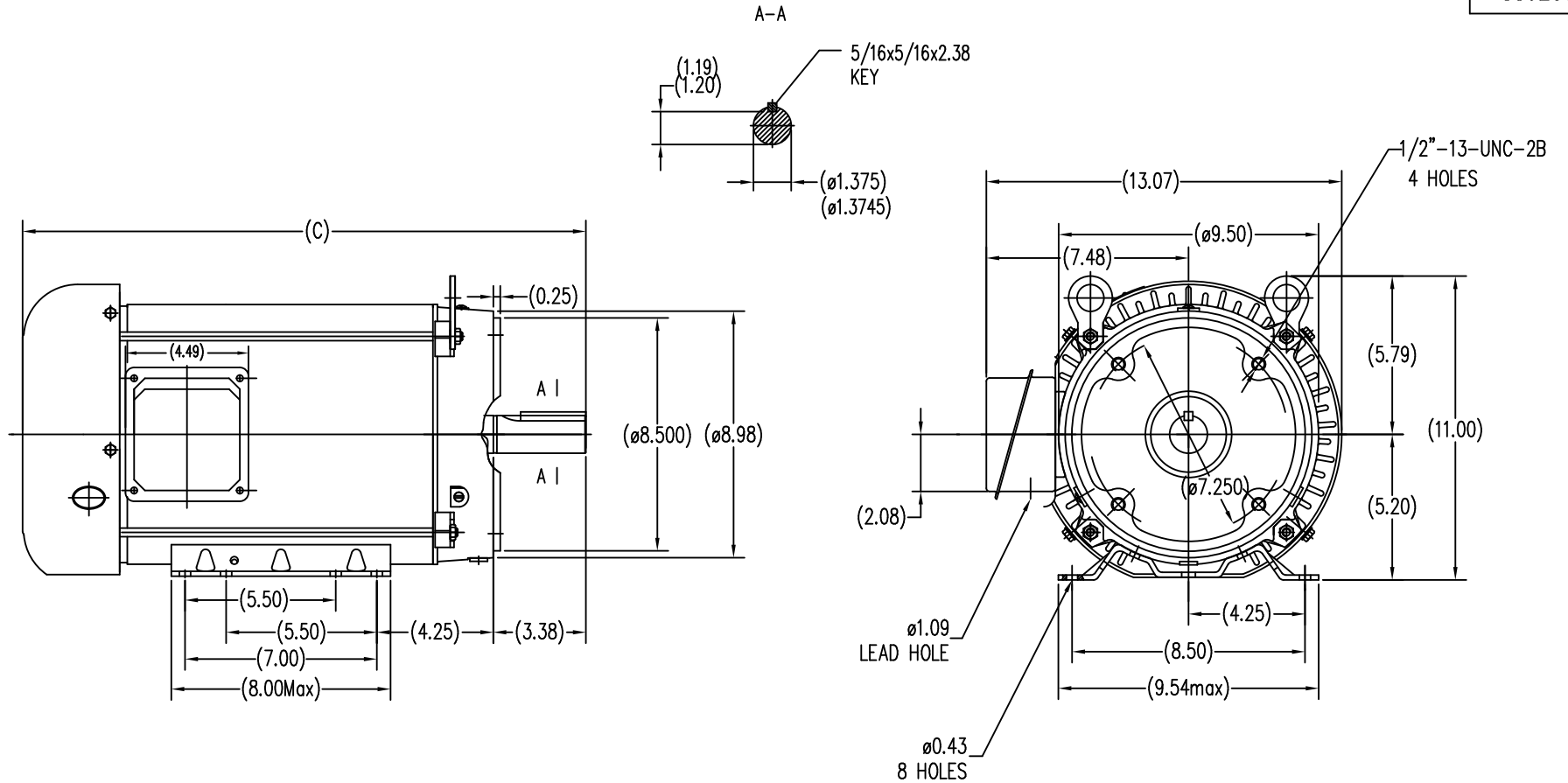

213TC	19.1
215TC	20.7
FRAME	C

		TOLERANCES UNLESS SPECIFIED		REGAL REGAL-BELOIT CORPORATION		DRAWN ZXW 06-03-2015	
		DEC.	INCHES			CHK ZL 06-03-2015	
		.X	±.1			APPD ZYH 06-03-2015	
		.XX	±.03	TITLE		SCALE	
		.XXX	±.005	213/215TC-Face		REF	
		.XXXX	±.0005	MATL.		FMF REGAL-WUXI	
NO.	REVISION	BY & DATE	CHK	ANG	±1/2"	FINISH	PREV
THIS DRAWING IN DESIGN AND DETAIL IS OUR PROPERTY AND MUST NOT BE USED EXCEPT IN CONNECTION WITH OUR WORK ALL RIGHTS OF DESIGN AND INVENTION ARE RESERVED THIS IS AN ELECTRONICALLY GENERATED DOCUMENT - DO NOT SCALE THIS PRINT				RFP	CAD FILE	SS620688	SIZE
				DIST			DRAWING NO.
							B
							SS620688
							REV.
							2

EE7308

THREE PHASE
DUAL VOLTAGE MOTOR



VIEW OF TERMINAL END

REF.
WINDING DIAGRAM

T8Y, T2Y, T2BL, T4BX, T2EC, T2G
T6BZ, T2B, T6BL, T4AV, T6B, T4B

OPTIONAL CORD
CONNECTION

L1 — WHITE
L2 — RED
L3 — BLACK

NO.	REVISION	BY & DATE	CHK	ANG	TOLERANCES UNLESS SPECIFIED		FINISH	DRAWN RM 11/20/1990				
					DEC.	INCHES						
5	CHG TO REGAL LOGO	SL 09/10/2015	AB					CHK ML 11/21/1990				
4	REVISED IEC NOTATIONS	MSG 11/15/2011	CMN	.X	±.1			APPD SAS 04/24/2003				
3	ADDED IEC NOTATIONS... (U1), (V1) ETC. MU95194	MSG 5/10/2010	MJS	.XX	±.02			SCALE 1=1				
2	ADDED THE OPTIONAL CORD CONNECTION MU46318	RDH 04/24/2003	DRS	.XXX	±.005		TITLE CONNECTION DIAGRAM 3Ø - DUAL VOLTAGE MOTOR	REF				
1	REDRAWN	RM 11/20/1990		.XXXX	±.0005		MAT'L.	FMF				
					±7'30"			PREV				
THIS DRAWING IN DESIGN AND DETAIL IS OUR PROPERTY AND MUST NOT BE USED EXCEPT IN CONNECTION WITH OUR WORK ALL RIGHTS OF DESIGN AND INVENTION ARE RESERVED THIS IS AN ELECTRONICALLY GENERATED DOCUMENT - DO NOT SCALE THIS PRINT							RFP	CAD FILE ee7308	SIZE A	DRAWING NO. EE7308	PAGE OF 5	REV. 5
							DIST WP					



Regal Beloit America, Inc.

REGAL™
3Ø - DUAL VOLTAGE MOTOR



**P.O. BOX 8003
WAUSAU, WI 54401-8003
PH. 715-675-3311**

CERTIFICATION DATA SHEET

CUSTOMER: CUSTOMER PO #:
ORDER #: MODEL #: 215TTFBD6028 AA
CONN. DIAGRAM: A-EE7308 CUSTOMER PART #:
OUTLINE: B-SS620688 MOUNTING: F1/F2 CAPABLE
WINDING #: HE31324013 2

TYPICAL MOTOR PERFORMANCE DATA

HP	KW	SYNC. RPM	F.L. RPM	FRAME	ENCLOSURE	KVA CODE	DESIGN
10&7 1/2	7.50&5.60	1800	1762&1465	215TC	TEFC	H	B

PH	HZ	VOLTS	AMPS	START TYPE	DUTY	INSL	S.F.	AMB° C
3	60/50	230/460&190/380	25/12.5&23.2/11.6	LINE OR INVERTER	CONTINUOUS	F7	1.15/1.15	40

FULL LOAD EFF:	92.1&91	3/4 LOAD EFF:	91.6	1/2 LOAD EFF:	90.8	GTD. EFF	ELEC. TYPE
FULL LOAD PF:	81.3&81	3/4 LOAD PF:	76.6	1/2 LOAD PF:	66	91	SQ CAGE INV RATED

F.L. TORQUE	LOCKED ROTOR AMPS	L.R. TORQUE	B.D. TORQUE	F.L. RISE° C
29.8 LB-FT	158 / 79	59 LB-FT 198 %	74 LB-FT 248 %	70

SOUND PRESSURE @ 3 FT.	SOUND POWER	ROTOR WK^2	MAX. WK^2	SAFE STALL TIME	STARTS / HOUR	APPROX. MOTOR WGT
62 DBA	72 DBA	1.1 LB-FT^2	85 LB-FT^2	25 SEC.	2	210 LBS.

***** SUPPLEMENTAL INFORMATION *****

DE BRACKET TYPE	ODE BRACKET TYPE	MOUNT TYPE	ORIENTATION	SEVERE DUTY	HAZARDOUS LOCATION	DRIP COVER	SCREENS	PAINT
C-FACE	STANDARD	RIGID	HORIZONTAL	FALSE	NONE	FALSE	NONE	BLUE (ENAMEL)

BEARINGS	GREASE	SHAFT TYPE	SPECIAL DE	SPECIAL ODE	SHAFT MATERIAL	FRAME MATERIAL
DE ODE BALL BALL	POLYREX EM	T	NONE	NONE	1045 HOT ROLLED (C-204)	ROLLED STEEL

THERMOSTATS	THERMO-PROTECTORS			THERMISTORS	CONTROL	SPACE HEATERS
	PROTECTORS	WDG RTDS	BRG RTDS			
NONE	NOT	NONE	NONE	NONE	FALSE	NONE

INVERTER
 TORQUE: CONSTANT 4:1/VARIABLE 20:1
 INV. HP SPEED RANGE: NONE
ENCODER: NONE
 NONE NONE
 NONE NONE PPR
BRAKE: NONE NONE
 NONE P/N NONE
 NONE NONE
 NONE FT-LB NONE V NONE HZ

*

PREPARED BY: Fareeda Dudekula
DATE: 05/11/2018 07:34:20 AM
FORM 3531 REV.3 02/07/99
 ** Subject to change without notice.

Data Sheet

Date: 5/3/2018

2151TFBD6028

Customer:
 Attention:
 Submitted by: FAREEDA DUDEKULA



Submital
 Data @ 460 V

Load	0%	25%	50%	75%	100%	115%	125%	LR
Current (Amps)	5.6	6.2	7.8	10.0	12.5	14.3	15.5	79.0
Torque (ft-lb)	0.00	7.3	14.7	22.2	29.8	34.4	37.4	59.0
RPM	1800	1792	1782	1772	1762	1,756	1752	0
Efficiency (%)		87.5	91.0	91.7	91.7	91.0	90.2	
P.F. (%)	6.0	43.0	65.5	76.0	81.5	83.0	83.5	44.0

Motor Speed Data

	LR	Pull-Up	BD	Rated	Idle
Speed (RPM)	0	900	1565	1762	1800
Current (Amps)	79.0	73.0	45.0	12.5	5.6
Torque (ft-lb)	59.0	51.0	74.0	29.8	0.00

Information Block

HP	10.0			
Sync. RPM	1800			
Frame	215182TFC6080			
Enclosure	TEFC			
Construction	TFC			
Voltage	230/460#190/380 V			
Frequency	60 Hz			
Design	B			
LR Code letter	H			
Service Factor	1.15			
Temp Rise @ FL	70 °C			
Duty	CONT			
Ambient	40 °C			
Elevation	1,000 feet			
Rotor/Shaft wk²	1.10 Lb-Ft²			
Ref Wdg	HE31324013 NONE			
Sound Pressure @ 1M	62 dbA			
VFD Rating	CONSTANT 10:1			
Outline Dwg	B-SS620688			
Conn. Diag	A-EE7308			
Additional Specifications:				
0				
0				
R1	R2	X1	X2	Xm
0.7410	0.4660	2.1470	2.5790	46.7750
EQUIV/CKT (OHMS/PHASE)				

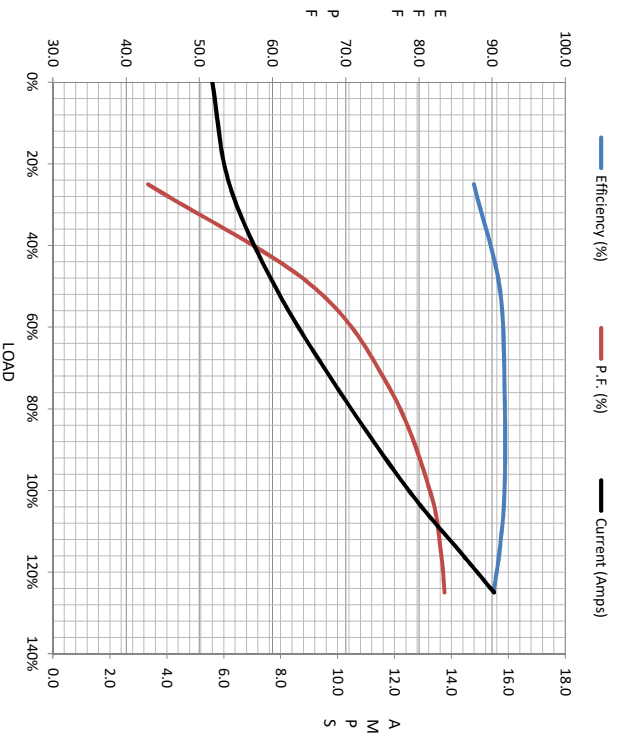

Speed - Torque Curve

