

*Medidas en mm.

CANAL VERTICAL

Longitud (L)		Altura (A)		Canal	Código
mm	pul	mm	pul		
3050	120	18	5/7	POCO PROFUNDO	MCV-01
3050	120	30	1 1/6	PROFUNDO	MCV-02

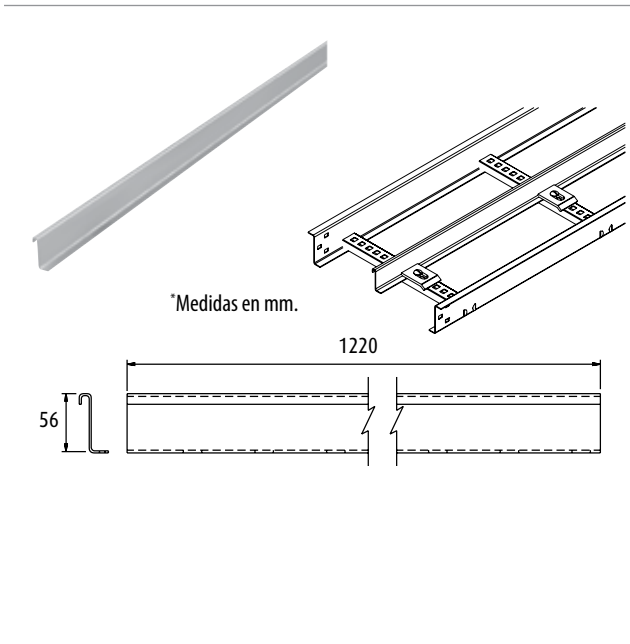

*Medidas en mm.

SEPARADOR PARA TRAMO RECTO

Código

MTR-S-122

Para peraltes 4", 5" y 6" agregar P4, P5 y P6 respectivamente al final de cada código.

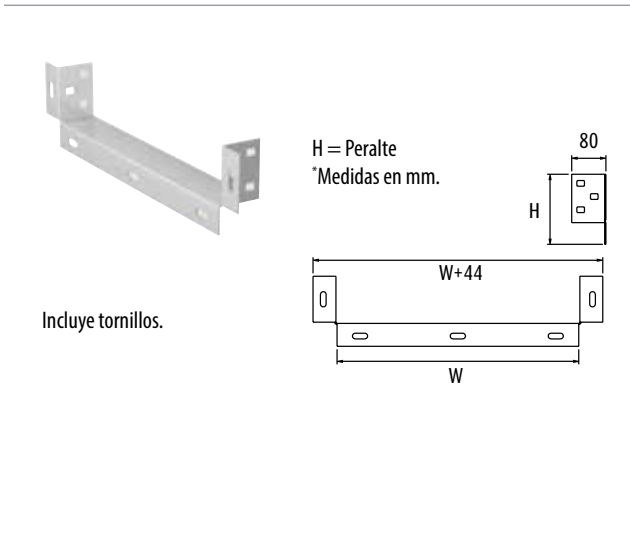

H = Peralte
*Medidas en mm.

Incluye tornillos.

CONECTOR DE ESCALERA A CAJA

Ancho charola (W)		Código
mm	pul	
102	4	MCE-04
152	6	MCE-06
229	9	MCE-09
305	12	MCE-12
406	16	MCE-16
457	18	MCE-18
508	20	MCE-20
610	24	MCE-24
762	30	MCE-30
914	36	MCE-36