

LISTEN.  
THINK.  
SOLVE.®

# Solid-State Pressure Sensors



**USER MANUAL**

**836E**

# Important User Information

Solid-state equipment has operational characteristics differing from those of electromechanical equipment. Safety Guidelines for the Application, Installation and Maintenance of Solid-State Controls (Publication SGI-1.1 available from your local Rockwell Automation sales office or on-line at <http://www.ab.com/manuals/gi>) describes some important differences between solid-state equipment and hard-wired electromechanical devices. Because of this difference, and also because of the wide variety of uses for solid-state equipment, all persons responsible for applying this equipment must satisfy themselves that each intended application of this equipment is acceptable.

In no event will Rockwell Automation, Inc. be responsible or liable for indirect or consequential damages resulting from the use or application of this equipment.

The examples and diagrams in this manual are included solely for illustrative purposes. Because of the many variables and requirements associated with any particular installation, Rockwell Automation, Inc. cannot assume responsibility or liability for actual use based on the examples and diagrams.

No patent liability is assumed by Rockwell Automation, Inc. with respect to use of information, circuits, equipment, or software described in this manual.

Reproduction of the contents of this manual, in whole or in part, without written permission of Rockwell Automation, Inc. is prohibited.

Throughout this manual, when necessary we use notes to make you aware of safety considerations.

---

## WARNING



Identifies information about practices or circumstances that can cause an explosion in a hazardous environment, which may lead to personal injury or death, property damage, or economic loss.

---

## IMPORTANT

Identifies information that is critical for successful application and understanding of the product.

---

## ATTENTION



Identifies information about practices or circumstances that can lead to personal injury or death, property damage, or economic loss. Attentions help you:

- identify a hazard
- avoid a hazard
- recognize the consequence

---

## SHOCK HAZARD



Labels may be located on or inside the equipment (e.g., drive or motor) to alert people that dangerous voltage may be present.

---

## BURN HAZARD



Labels may be located on or inside the equipment (e.g., drive or motor) to alert people that surfaces may be dangerous temperatures.

---

## Table of Contents

<b>1</b>	<b>Safety Instructions</b>	<b>4</b>
1.1	Designated Use	4
1.2	Installation, Commissioning, and Operation	4
1.3	Operational Safety	4
1.4	Return	4
<b>2</b>	<b>Product Identification</b>	<b>5</b>
<b>3</b>	<b>Installation</b>	<b>6</b>
3.1	Dimensions	6
3.2	Process Connection	7
3.3	Installation Instructions	8
3.4	Wiring	9
3.5	Mating Cables	10
<b>4</b>	<b>Operation</b>	<b>11</b>
4.1	On-Site Programming	11
4.2	Programming with Personal Computer and ReadWin 2000	19
<b>5</b>	<b>Accessories</b>	<b>21</b>
5.1	Process Connection	21
5.2	Welding Bosses	24
5.3	Configuration Kit with ReadWin	25
<b>6</b>	<b>Troubleshooting</b>	<b>26</b>
6.1	Error and Warning Codes	26
6.2	Spare Parts	27
6.3	Repair	27
6.4	Change Status	27
<b>7</b>	<b>Technical Data</b>	<b>28</b>
7.1	Display Version	28
7.2	Nondisplay Version	29
7.3	Pressure Conversion Chart	30

## 1 Safety Instructions

### 1.1 Designated Use

The Bulletin 836E is a pressure switch for measuring and monitoring absolute and gauge pressures. The device has been safely built with state-of-the-art technology and meets the applicable requirements and EC Directives. It can, however, be a source of danger if used incorrectly or for anything other than the designated use.

### 1.2 Installation, Commissioning, and Operation

Only personnel familiar with these types of products and associated machinery should plan or implement the installation, start-up, configuration, and subsequent maintenance of the Bulletin 836E pressure switch. Failure to comply may result in personal injury and/or equipment damage.

### 1.3 Operational Safety

- Functional safety  
The Bulletin 836E pressure switches were developed according to the standards IEC 61508 and IEC 61511-1 (FDIS).
- Hazardous areas  
The Bulletin 836E is not approved for use in intrinsic safety (hazardous area) applications.

### 1.4 Return

Before returning a device to Rockwell Automation, be sure to remove all fluid residue. This is particularly important if the fluid is a health hazard, e.g. flammable, toxic, caustic, carcinogenic, etc.



**ATTENTION:** Do not return a measuring device if you are not absolutely certain that all traces of hazardous substances have been removed, e.g. substances which have penetrated crevices or diffused through plastic.

---

## 2 Product Identification

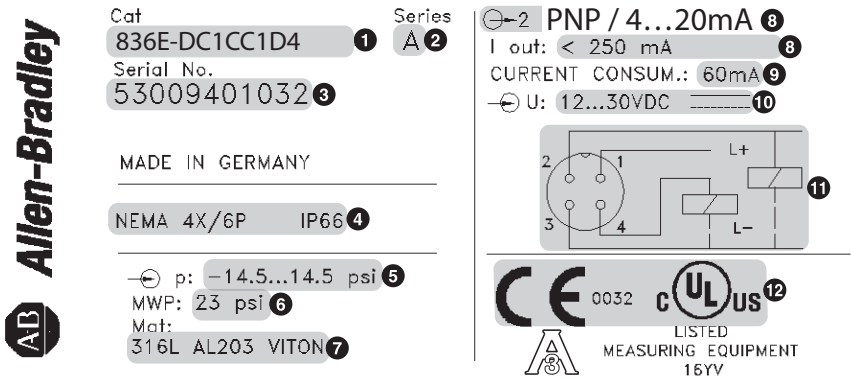

Fig. 1: Explanation of the nameplate - see table below

1	Catalog number	6	Max. working pressure	11	Wiring diagram
2	Series letter	7	Wetted part materials	12	Approvals
3	Serial number	8	Output		
4	Enclosure rating / Ingress protection	9	Current consumption		
5	Operating pressure	10	Operating voltage		

**Notes:**

- Specifications and ratings may differ from those shown in Figure 1, depending on particular model. Refer to product nameplate or catalog for actual ratings and specifications.
- The series number indicates the version of the switch. A change in the series letter does not have any effect on the compatibility (see also Section 6 — Troubleshooting).
- The MWP (maximum working pressure) is specified on the nameplate. This value refers to a reference temperature of +20 °C (68 °F) and may be applied to the device for an unlimited time.
- The test pressure (Over Pressure Limit [OPL]) corresponds to 1.5 times the MWP and may be applied only for a limited time before causing damage to the switch.

### 3 Installation

#### 3.1 Dimensions

##### 3.1.1 Display Version

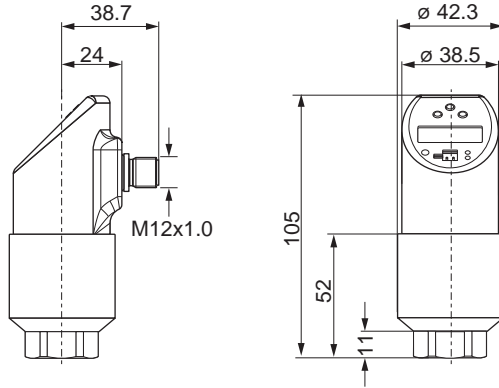
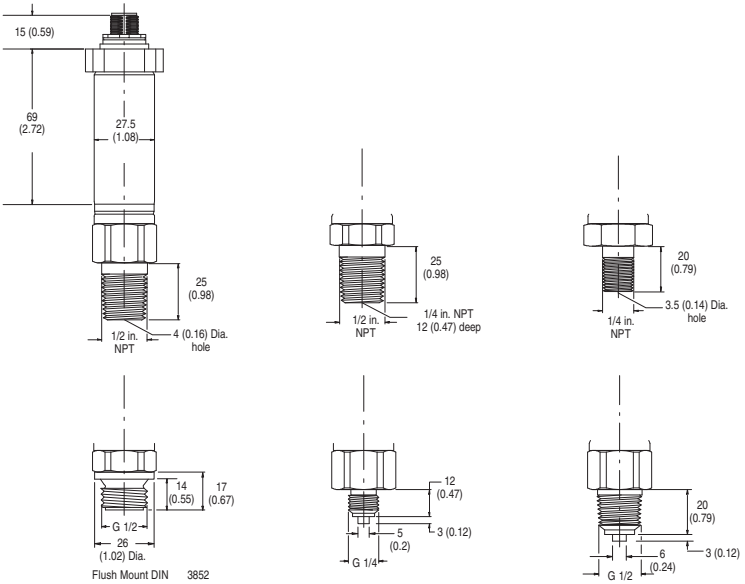

Fig. 2: Dimensions

##### 3.1.2 Nondisplay Version



### 3.2 Process Connection

The following table outlines the characteristics of the Bulletin 836E, its process, and sanitary connections.

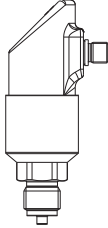
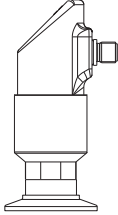
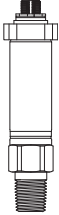
836E Pressure Switch		836E Nondisplay	
			
Measuring cell	Piezoresistive measuring cell and metallic measuring diaphragm	With piezoresistive measuring cell and metallic measuring diaphragm for sanitary applications	Piezoresistive measuring cell and metallic measuring diaphragm
Application	Measurement and monitoring of absolute and gauge pressures	Measurement and monitoring of absolute and gauge pressures in sanitary applications	Measurement and monitoring of absolute and gauge pressures
Process connection <sup>①</sup>	Thread – 1/4 NPT female – 1/4 NPT male – G 1/4 BSPP female – G 1/4 BSPP male – SAE 7/16...20 UNF female – SAE 7/16...20 UNF male	Sanitary – Clamp 1...1½ in. – Clamp 2 in.	Thread – 1/2 NPT male – 1/4 NPT male – 1/2 NPT male – 1/4 NPT female – G 1/2 male – G 1/4 male
Measuring range <sup>②</sup>	-14.5...+14.5 psi (-1...1 bar) 0...58psi (0...4 bar) 0...145 psi (0...10 bar) 0...580 psi (0...40 bar) 0...1450 psi (0...100 bar) 0...6000 psi (0...400 bar)	0...1 bar/15 psi to 0...40 bar/600 psi	0...15 psi (0...1 bar) 0...50 psi (0...3 bar) 0...150 psi (0...10 bar) 0...500 psi (0...34 bar) 0...1500 psi (0...103 bar) 0...6000 psi (0...413 bar)
Process temperature	-40...+100 °C (-40...+212 °F)	-40...+100 °C (135 °C max. 1 hour)	-25...+70 °C (-13...158 °F)

**Notes:**

- ① Male adapters cannot be used with the 0...1450 psi or the 0...6000 psi display models
- ② For conversion of psi to other units (bar, kPa, etc.), refer to inside back cover of this document

### 3.3 Installation Instructions

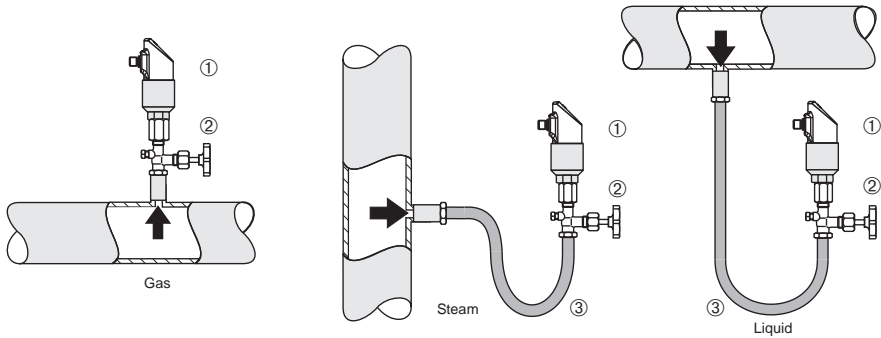

Fig. 3: Typical applications of the Bulletin 836E to measure pressure in gases, steam and liquids.

- ① Bulletin 836E, pressure switch
- ② Shut-off assembly
- ③ U-pipe

For typical applications of the Bulletin 836E, see Figure 3 above:

- The image on the left illustrates how the 836E should be applied for pressure measurement in gases. The switch should be mounted with a shut-off assembly above the sampling nozzle so that any condensate can drain off into the process.
- The center image shows the correct installation for pressure measurement in steam. Note how the Bulletin 836E is mounted with a U-pipe below the sampling nozzle. Fill the U-pipe with fill fluid before commissioning.
- For pressure measurement in liquids, see the drawing on the right of Figure 3 above. The Bulletin 836E should be mounted below or at the same level as the sampling nozzle.

Additional considerations:

- Do not mount the device in the product flow or at a point where it could be affected by pressure pulses.
- Calibration and testing are easier if the device is mounted downstream of a shut-off assembly.
- The orientation of the Bulletin 836E can result in zero point shift, i.e. the measured value does not display zero in a non-pressurized state. This zero point shift can be corrected (see Section 4 – Operation).
- The digital display can be electronically rotated 180° (see Section 4 – Operation).
- The housing can be rotated up to 310° for optimal readability and ease of wiring.



### 3.4 Wiring

#### 3.4.1 Display Version

The 836E is a DC voltage switch with two PNP outputs or a single PNP output with a 4...20 mA analog output. Both options feature an M12 (micro) connector.

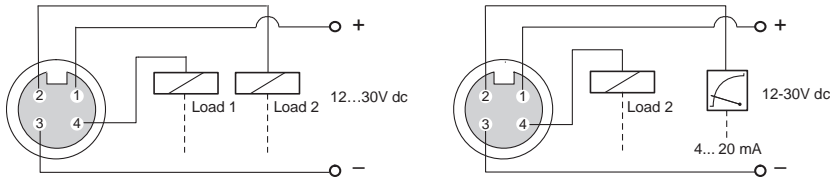
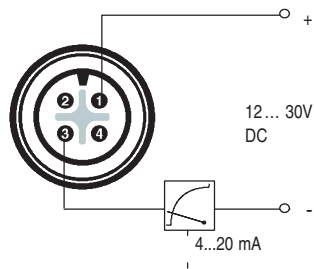

Fig. 4: Bulletin 836E with two PNP switch outputs or one PNP output with 4...20 mA analog output.

#### 3.4.2 Nondisplay Version

The nondisplay version is offered with 4...20 mA analog output.



### 3.5 Mating Cables

2m (6.5ft) PVC Cable with 4-pin micro (M12x1) connector and ratcheted epoxy-coated zinc coupling nut.  
Catalog number: **889D-F4AC-2**

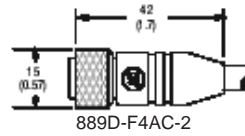

2m (6.5ft) PVC Cable with 4-pin micro (M12x1) right-angle connector and ratcheted epoxy-coated zinc coupling nut.  
Catalog number: **889D-R4AC-2**

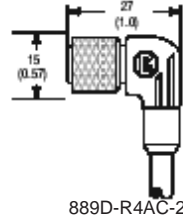

**Note:** Other cable lengths are available and shielded cables may be required for some analog output applications – refer to the On-Machine Connectivity catalog (publication #M115-CA001A-EN-P) for additional information.

## 4 Operation

### 4.1 On-Site Programming

The Bulletin 836E is programmed via three push buttons. The digital display and the light emitting diodes (LEDs) assist in the navigation through the operating menu.

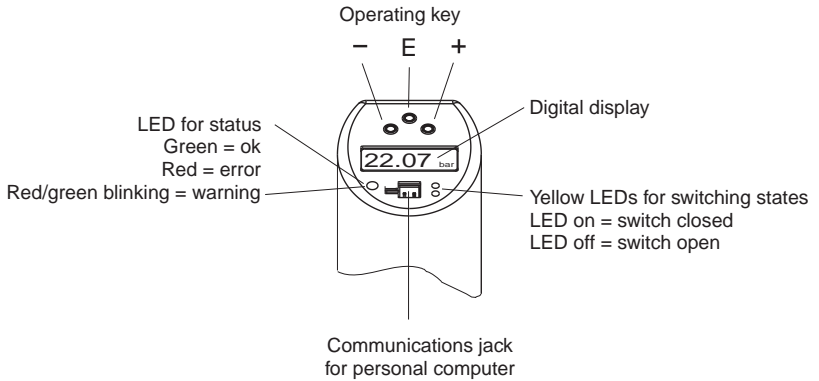

Fig. 5: Location of operating keys and display elements

## 4.1.1 Navigating Through the Programming Menu

Refer to the menu structure in Figure 4.1.2 on the following page.

The section labeled A refers to Function groups

The section labeled B refers to the individual Functions within each Function group

The section labeled C identifies the possible values for each function

① To enter the operating menu:

- Press and hold the E key for longer than 3 sec.

② Once in programming mode (BASE will be displayed), toggle between the Function groups with the + and – keys

③ To enter the Function group, press the E key

④ To toggle between functions, repeatedly press the E key (Note that repeatedly pressing the E key will return you to the Function group.

- Then press the E key to return to the “Function” option

⑤ Once on the desired function, use the + or – key to change the function value

⑥ Press E to accept the function value

⑦ To save changes, press and hold the E key for longer than 3 sec.

- Once in SAVE, choose YES or NO with the + or – key
- Confirm with the E key (sensor will go through a start-up routine before entering operating mode)
- Warning code 210 (W210) will appear on the display to indicate a change in configuration (see Chapter 6, ‘Troubleshooting’ for further explanations of Error and Warning codes).



**ATTENTION:** Changes take effect only when you choose YES when asked to save the data.

---

### 4.1.2 Structure of the Programming Menu

The chart below illustrates the structure of the programming menu.

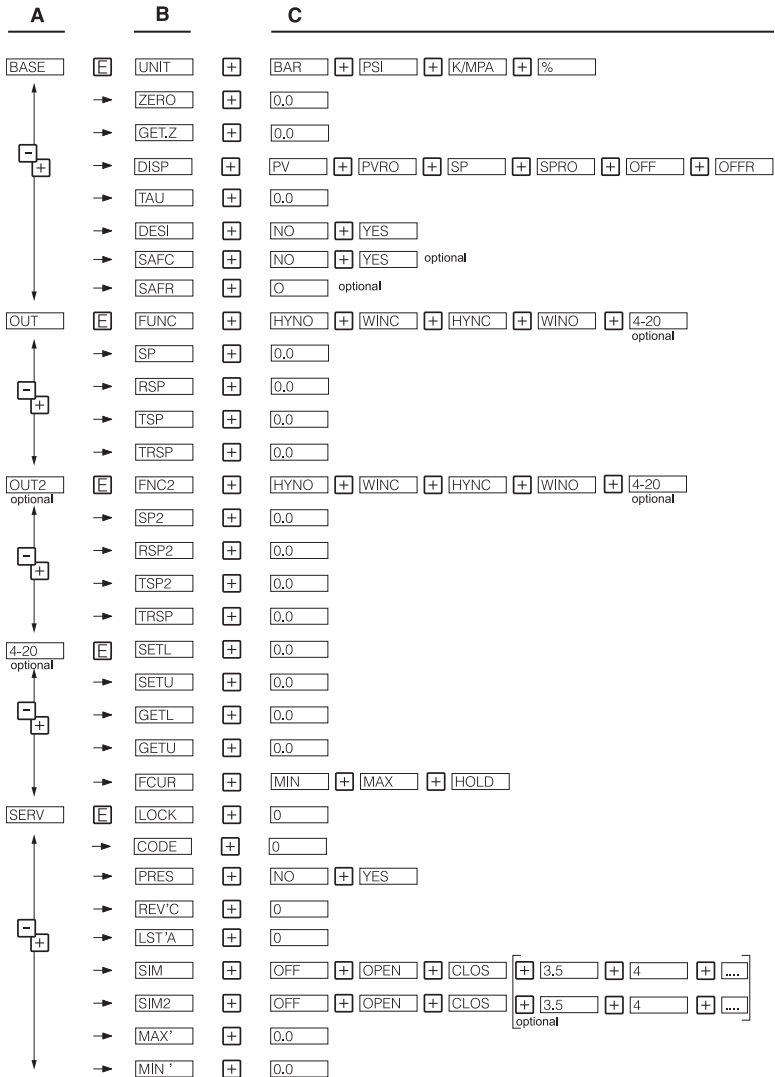

Fig. 6: Programming menu: A=function groups, B=functions, C=settings

**4.1.3 Basic Settings**

Base	Basic settings			
BASE	UNIT	Unit of measure	BAR PSI KPA 1/1	Select technical unit: bar psi kPa %
	ZERO	Configure zero point	0.00	Position adjustment: within $\pm 20\%$ of the upper range limit
	GET.Z	Accept zero point	0.00	Current value as zero point (max. $\pm 20\%$ of the upper range limit)
	DISP	Display	PV PVRO SP SPRO OFF OFFR	PV: measured value display PVRO: measured value display rotated 180° SP: set set point display SPRO: set point display rotated 180° OFF: display off OFFR: display off rotated 180°
	TAU	Damping: display value, output signal	0.0	0...40 sec.
	DESIN	DESINA	NO YES	Connection in accordance with DESINA guidelines

### 4.1.4 Output Setting

- Hysteresis mode  
The hysteresis mode allows for two-point control. Depending on the pressure  $p$ , the hysteresis can be set via the set point SP and the reset point RSP.
- Window mode  
The window mode enables process pressure range monitoring.
- Analog output mode  
The analog output mode returns a 4...20 mA signal proportional to the measured value. The upper and lower range values can be set by the user.
- Factory default settings  
Set point SP 1: 45%; Reset point RSP 1: 44.5%  
Set point SP 2: 55%; Reset point RSP 2: 54.5%  
Analog output: Lower Range Value (LRV) 0%; Upper Range Value (URV) 100%
- Each set point can be selected as Normally Open (N.O) or Normally Closed (N.C.)

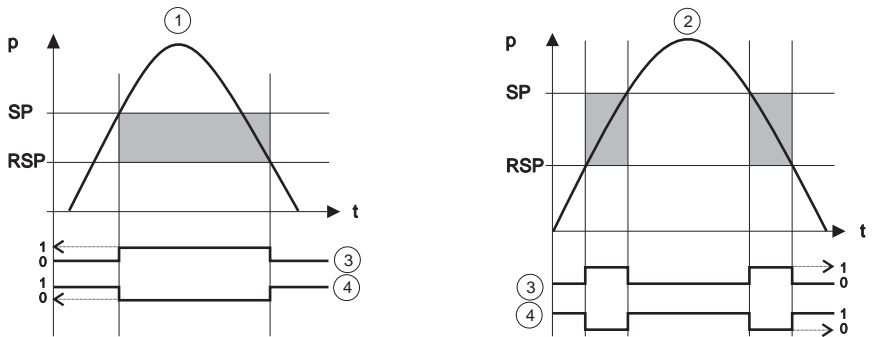

•P01-PTx3xxxx-05-xx-xx-xx-001

Fig. 7: ① Hysteresis mode, ② Window mode, ③ Switch status of NO contact, ④ Switch status of NC contact

**Note:** SP = set point; RSP = reset point

OUT/OUT2	Output/Output 2			
<p>OUT</p> <p>OUT2</p>	<p>FUNC</p> <p>FNC2</p>	<p>Switching mode</p>	<p>HYNO</p> <p>HYNC</p> <p>WIND</p> <p>WINC</p> <p>4--20</p>	<p>HYNO: Hysteresis/NO contact</p> <p>HYNC: Hysteresis/NC contact</p> <p>WIND: Window/NO contact</p> <p>WINC: Window/NC contact</p> <p>4...20 mA: Analog mode (analog output versions only)</p>
	<p>SP</p> <p>SP2</p>	<p>Set point value</p>	<p>0.0</p>	<p>Set point 0.5...100% URL in increments of 0.1% (min. 0.001 bar)</p>
	<p>RSP</p> <p>RSP2</p>	<p>Reset point value</p>	<p>0.0</p>	<p>Reset point 0...99.5% URL in increments of 0.1% (min. 0.001 bar)</p>
	<p>TSP</p> <p>TSP2</p>	<p>Set point delay</p>	<p>0.0</p>	<p>Delay time 0...99 sec. in increments of 0.1 sec.</p>
	<p>TRSP</p> <p>TRSP2</p>	<p>Reset point delay</p>	<p>0.0</p>	<p>Delay time 0...99 sec. in increments of 0.1 sec.</p>
<p>Min. distance between SP and RSP: 0.5% URL</p>				



4 - 20	Analog output			
4--20	SETL	Value for 4 mA (LRV)	0.0	Enter lower range value in increments of 0.1%
	SETU	Value for 20 mA (URV)	20.0	Enter upper range value in increments of 0.1%
	GETL	Pressure applied for 4 mA (LRV)	0.0	Use measured pressure as lower range value
	GETU	Pressure applied for 20 mA (URV)	20.0	Use measured pressure as upper range value
	FCUR	Error current	MIN' MAX' HOLD	Current value in event of error: MIN = $\leq 3.6$ mA MAX = $\geq 21.0$ mA HOLD = last value
Range of adjustment: LRL = Lower Range Limit; URL = Upper Range Limit; LRV = Lower Range Value; URV = Upper Range Value				
Turndown up to 4:1, LRV must be lower than URV				

### 4.1.5 Service Function Setting

- Locking Code

A locking code already assigned can only be changed by first entering the old code for enabling the device.

SERV	Service functions			
SERV LOCK	LOCK	Security locking/ password protection	<input checked="" type="checkbox"/>	Enable password protection
CODE	CODE	Password/code entry	<input checked="" type="checkbox"/>	Select code 1...9999 0 = no locking
PRES	PRES	Reset	NO YES	Reset all entries to the factory setting
REV.C	REV.C	Revision counter	<input checked="" type="checkbox"/>	Increases by 1 with each configuration
LSTA	LSTA	Last device status	<input checked="" type="checkbox"/>	Displays the last device status to occur ≠0
SIM SIM2	SIM SIM2	Simulation output 1 or 2	OFF OPEN CLOS 3.5	OFF: No simulation OPEN: Switch output open CLOS: Switch output closed 3.5: Simulation values for analog output in mA (3.5/4.0/8.0/12.0/16.0/20.0/21.7)
MAX'	MAX'	Max. indicator	<input checked="" type="checkbox"/>	Display of max. measured process value
MIN'	MIN'	Min. indicator	<input checked="" type="checkbox"/>	Display of min. measured process value

## 4.2 Programming with Personal Computer and ReadWin 2000

The 836E can also be configured via personal computer and ReadWin software. An additional configuration kit with a cable (Cat. No. 836E-NSR) is required to interface the USB port of the PC to the programming port of the pressure sensor, as shown below.

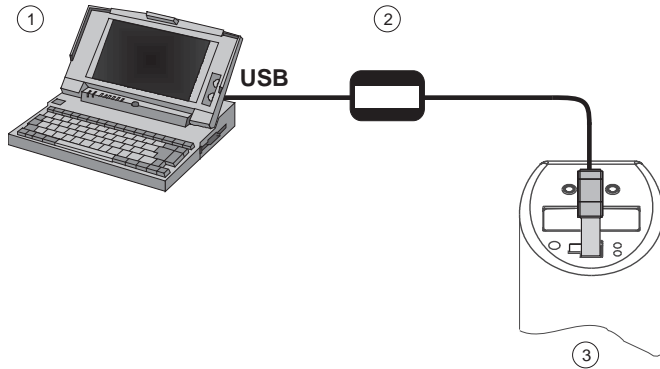

Fig. 8: Programming with PC

- ① Personal computer with ReadWin configuration software
- ② Configuration kit (836E-NSR)
- ③ Bulletin 836E with programming port

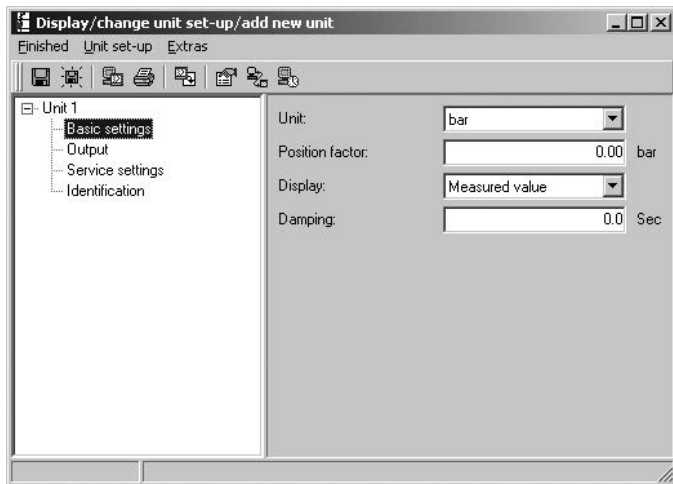

Fig. 9: Sensor configuration with ReadWin

## 4.2.1 Additional Operating Options

In addition to the operating options listed in the “On-site programming” section, the ReadWin configuration software provides an additional function group with further information on the Bulletin 836E:

Function group	Description
SERV	Number of switch changes for output 1
	Number of switch changes for output 2
	Device status
	Last error to occur
INFO	Tag number
	Switch serial number
	Sensing element serial number
	Electronics serial number
	Series number
	Hardware version
	Software version

## 5 Accessories

### 5.1 Process Connection

- 836E

The process connection is an adapter and the sensor module has an adapter thread. As a result, the process connection can be easily changed at a later stage.

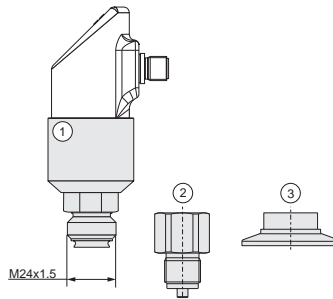

Fig. 10: Process connection

- ① Sensor module 836E
- ② Adapter with threaded connection
- ③ Adapter with clamp connection (sanitary)

## 5.1.1 Adapter Change

The adapter can be changed on 836E.

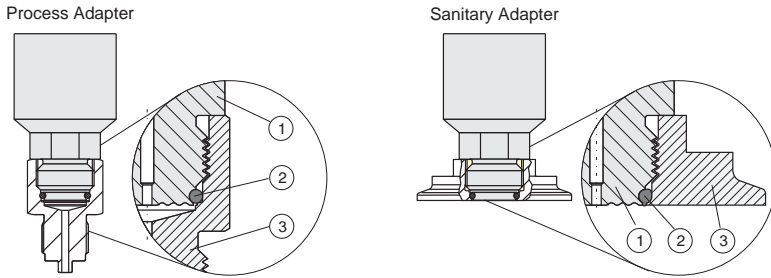

Fig. 11: Changing the adapter

- ① Sensor module with adapter thread
- ② Standard O-ring
- ③ Adapter

Please note the following when changing the adapter:

- Use a new O-ring. Diameter 15.54 x 2.62 mm (0.61 x 0.10 in.) with either EPDM 70 Shore FDA or FKM 70 Shore FDA material
- The sensor can be mounted with a 27 mm open-ended wrench.
- The adapter can be threaded on and tightened with a 28 or 32 mm (1.1 or 1.26 in.) open-ended wrench (depending on the process connection). The maximum torque is 80 N•m. The adapter can become loose if exposed to severe strain through pressure and temperature. For this reason, the adapter connection must be checked regularly and the tightened if necessary. We recommend using Teflon™ tape as an additional thread seal.
- When changing the adapter, take care to not damage the diaphragm of the pressure sensing element.

### 5.1.2 Adapter Versions

Catalog numbers for thread adapter versions (see diagram for dimensions):

**Process Adapters**

- G1/4 female: 836E-NP73
- G1/4 male: 836E-NP76
- 7/16 - 20UNF female: 836E-NP72
- 7/16 - 20UNF male: 836E-NP75
- 1/4-in. NPT female: 836E-NP71
- 1/4-in. NPT male: 836E-NP74

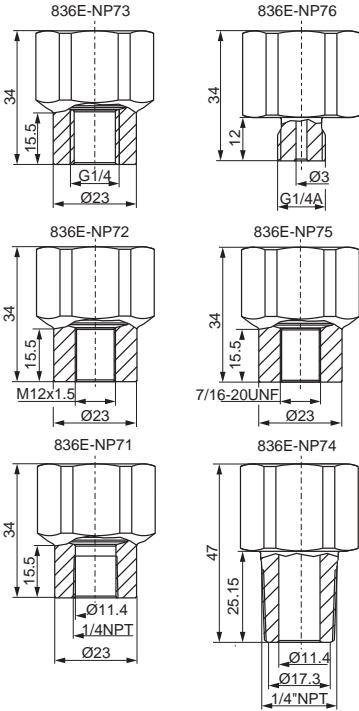

**Sanitary Adapters**

- 1 to 1-1/2-in. clamp: 836E-NH7B
- 2-in. clamp: 836E-NH7C

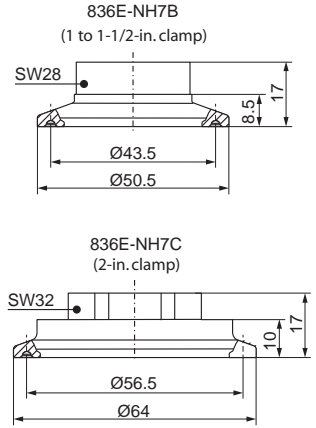

## 5.2 Welding Bosses

### 5.2.1 Welding Boss with Sealing Taper

Welding boss for flush mounting process connection with metallic sealing taper.

Material: AISI 316L

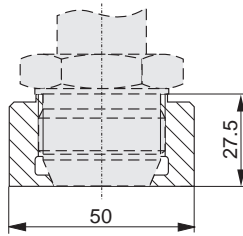

Fig. 12: 836E-NWT

### 5.2.2 Welding Boss with Sealing Surface

Welding boss for flush mounting process connection with sealing surface.

Material: AISI 316L

Seal (enclosed): silicone O-ring

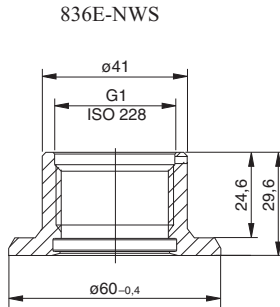

Fig. 13: 836E-NWS



### 5.3 Configuration Kit with ReadWin

The configuration kit (Cat. No. 836E-NSR) consists of a software CD and a conversion cable which interfaces the USB port of the PC to the 4-pin programming port on the sensor face.

ReadWin® 2000 software is also available free of charge via download from [www.ab.com/sensors/products/condsensingswitches](http://www.ab.com/sensors/products/condsensingswitches)

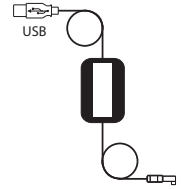
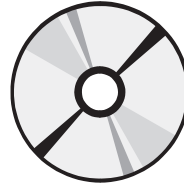

## 6 Troubleshooting

### 6.1 Error and Warning Codes

If an error occurs in the electronics, the color of the status LED changes from green to red and the display shows an error or warning code, as outlined below:

- E-code for errors  
In the event of an error message, the measured value is unreliable.
- W-code for warnings  
In the event of a warning, the measured value is still reliable.

#### Error Codes

Code	Explanation
E011	Device configuration faulty
E012	Error in measurement
E015	Device error (internal)
E019	Power supply has under voltage/over voltage
E020	Device error (internal)
E021	Device error (internal)
E022	USB supply voltage
E025	Switching contact 1 is not open, although it should be open
E026	Switching contact 2 is not open, although it should be open
E040	Device error (internal)
E042	Output current cannot be generated. Possible cause: analog output not connected
E044	Excessive output current drift ( $\pm 0.5$ mA)

## Warning Codes

Code	Explanation
W107	Simulation active
W202	Pressure outside the sensor range
W209	Device start-up
W210	Configuration modified
W212	Sensor signal outside the permitted range
W250	Number of switch cycles exceeded
W270	Short-circuit at output 1
W280	Short-circuit at output 2

## 6.2 Spare Parts

O-ring for adapter change

- O-ring 15.54 x 2.62 mm (0.61 x 0.10 in.), EPDM 70 Shore FDA, Catalog no. 836E-NV1
- O-ring 15.54 x 2.62 mm (0.61 x 0.10 in.), FKM 70 Shore FDA, Catalog no. 836E-NV2

## 6.3 Repair

Bulletin 836E pressure switches are not repairable.

## 6.4 Change Status

The release number on the nameplate and in the Operating Instructions indicates the change status of the device: XX.YY.ZZ (example 01.02.01).

XX	Change in the main version. Compatibility no longer provided. Device and Operating Instructions change.
YY	Change in functionality and operation. Compatibility provided. Operating Instructions change.
ZZ	Troubleshooting and internal modifications. Operating Instructions do not change.

## 7 Technical Data

### 7.1 Display Version

#### 7.1.1 Power Supply

Supply voltage

- DC voltage version  
12...30V DC

Current consumption

- Without load < 60 mA, with reverse polarity protection

Power supply failure

- Behavior in case of over voltage  
The device works continuously without any damage up to 34V DC.  
If the supply voltage is exceeded, the properties specified are no longer guaranteed.
- Behavior in case of under voltage  
If the supply voltage drops below the minimum value, the device switches off (status as if not supplied with power = switch open).

#### 7.1.2 Output

Switching capacity

- Switch status ON:  $I_a \leq 250 \text{ mA}$
- Switch status OFF:  $I_a \leq 1 \text{ mA}$
- Switching cycles: > 10 000 000
- Voltage drop PNP:  $\leq 2\text{V}$
- Overload protection  
Automatic load check of switching current; output is switched off in case of over current, the switching current is tested again every 0.4 sec.; max. capacitance load: 14  $\mu\text{F}$  at max. supply voltage (without resistive load) max. period length: 0.5 sec.; min.  $t_{\text{on}}$ : 40  $\mu\text{s}$

Load (analog output)

- Max.  $(V_{\text{supply}} - 6.5\text{V})/0.022 \text{ A}$

Input PLC

- Input resistance  $R_i \leq 2 \text{ k}\Omega$   
Input current  $I_i \geq 10 \text{ mA}$

Signal on alarm

- Analog output  
 $\leq 3.6 \text{ mA}$  / last current value /  $\geq 21.0 \text{ mA}$  adjustable  
(if setting  $\geq 21.0 \text{ mA}$  the output is  $\geq 21.5 \text{ mA}$ )
- Signal outputs  
In safe state (switch normally open)

### 7.1.3 Operating Conditions

Any orientation

Any position-dependent zero shift can be corrected

Position adjustment (offset):  $\pm 20\%$  of the upper range limit

Operating conditions: Environment

- Ambient temperature range  
 $-40\dots+85\text{ }^{\circ}\text{C}$  (briefly up to  $+100\text{ }^{\circ}\text{C}$  [ $212\text{ }^{\circ}\text{F}$ ]), ( $-40\dots+185\text{ }^{\circ}\text{F}$ )
- Storage temperature  
 $-40\dots+85\text{ }^{\circ}\text{C}$  ( $-40\dots+185\text{ }^{\circ}\text{F}$ )

Operating conditions: Process

- Medium temperature ranges  
 $-40\dots+100\text{ }^{\circ}\text{C}$  ( $-40\dots+212\text{ }^{\circ}\text{F}$ )

Limiting medium pressure range

- For overload resistance, see nameplate (Section 2)
- Vacuum resistance:  $10\text{ mbar}_{\text{abs}}$

Material: AISI 316L

## 7.2 Nondisplay Version

### 7.2.1 Power Supply

Supply voltage

- DC voltage version  
 $12\dots30\text{V DC}$

Current consumption

- $20\text{ mA}$

### 7.2.2 Output

Output signal

- $4\dots20\text{ mA}$

Maximum load

- Max.  $(V_{\text{supply}} - 12\text{V})/0.02\text{ A}$

### 7.2.3 Operating Conditions

Ambient temperature range

- $-25\dots+70\text{ }^{\circ}\text{C}$  ( $-13\dots+158\text{ }^{\circ}\text{F}$ )

Medium temperature range

- $-25\dots+70\text{ }^{\circ}\text{C}$  ( $-13\dots+158\text{ }^{\circ}\text{F}$ )

Storage temperature range

- $-40\dots+85\text{ }^{\circ}\text{C}$  ( $-40\dots+185\text{ }^{\circ}\text{F}$ )

### 7.3 Pressure Conversion Chart

To / From	kPa	bar	mbar	mmH <sub>2</sub> O	kg/cm <sup>2</sup>	atm	inch Hg	mm Hg	inch H <sub>2</sub> O	psi
kPa	1	10	10	102.0	0.0102	$9.869 \times 10^{-3}$	0.2953	7.501	4.016	0.14505
bar	100	1	$10^3$	$1.020 \times 10^2$	1.020	0.9869	29.530	750.1	401.6	14.505
mbar	0.1	$10^{-3}$	1	10.20	$1.020 \times 10^3$	$9.869 \times 10^{-4}$	0.0295	0.7501	0.4016	0.0145
mm H <sub>2</sub> O	$9.807 \times 10^{-3}$	$9.807 \times 10^{-5}$	$9.807 \times 10^{-2}$	1	$10^{-4}$	$9.678 \times 10^{-3}$	$2.891 \times 10^{-3}$	0.0734	0.0394	$1.4224 \times 10^{-3}$
kg/cm <sup>2</sup>	98.07	0.98077	980.7	$10^4$	1	0.9678	28.910	734.2	393.7	14.224
atm	101.3	1.013	1013	$1.033 \times 10^4$	1.033	1	29.922	7601	406.7	14.68
inch Hg	3.386	0.0339	33.864	345.9	0.0346	0.0334	1	2540	13.62	0.4912
mm Hg	0.1333	$1.333 \times 10^{-3}$	1.333	13.62	$1.362 \times 10^{-3}$	$1.316 \times 10^{-3}$	0.0394	1	0.5362	0.0193
inch H <sub>2</sub> O	0.2491	$2.491 \times 10^{-3}$	2.491	25.40	$2.54 \times 10^{-3}$	$2.458 \times 10^{-3}$	0.0734	8650	1	0.0361
psi	6.895	0.0689	68.948	704.3	0.0704	0.0680	2.036	51.71	27.73	1

Fig. 14: Pressure conversion chart



**[www.rockwellautomation.com](http://www.rockwellautomation.com)**

---

**Power, Control and Information Solutions Headquarters**

Americas: Rockwell Automation, 1201 South Second Street, Milwaukee, WI 53204-2496 USA, Tel: (1) 414.382.2000,

Europe/Middle East/Africa: Rockwell Automation, Vorstlaan/Boulevard du Souverain 36, 1170 Brussels, Belgium, Tel:

Asia Pacific: Rockwell Automation, Level 14, Core F, Cyberport 3, 100 Cyberport Road, Hong Kong, Tel: (852) 2887 4

Part No. 75054-003 Ver 04

© 2008 Rockwell Automation. Printed in the U.S.A.