

# Micro810 Programmable Controllers

Catalog Numbers 2080-LC10-12AWA, 2080-LC10-12QWB, 2080-LC10-12QBB, 2080-LC10-12DWD



## Important User Information

Solid-state equipment has operational characteristics differing from those of electromechanical equipment. Safety Guidelines for the Application, Installation and Maintenance of Solid State Controls (publication [SGL-1.1](#) available from your local Rockwell Automation sales office or online at <http://www.rockwellautomation.com/literature/>) describes some important differences between solid-state equipment and hard-wired electromechanical devices. Because of this difference, and also because of the wide variety of uses for solid-state equipment, all persons responsible for applying this equipment must satisfy themselves that each intended application of this equipment is acceptable.

In no event will Rockwell Automation, Inc. be responsible or liable for indirect or consequential damages resulting from the use or application of this equipment.

The examples and diagrams in this manual are included solely for illustrative purposes. Because of the many variables and requirements associated with any particular installation, Rockwell Automation, Inc. cannot assume responsibility or liability for actual use based on the examples and diagrams.

No patent liability is assumed by Rockwell Automation, Inc. with respect to use of information, circuits, equipment, or software described in this manual.

Reproduction of the contents of this manual, in whole or in part, without written permission of Rockwell Automation, Inc., is prohibited.

Throughout this manual, when necessary, we use notes to make you aware of safety considerations.



**WARNING:** Identifies information about practices or circumstances that can cause an explosion in a hazardous environment, which may lead to personal injury or death, property damage, or economic loss.



**ATTENTION:** Identifies information about practices or circumstances that can lead to personal injury or death, property damage, or economic loss. Attentions help you identify a hazard, avoid a hazard, and recognize the consequence



**SHOCK HAZARD:** Labels may be on or inside the equipment, for example, a drive or motor, to alert people that dangerous voltage may be present.



**BURN HAZARD:** Labels may be on or inside the equipment, for example, a drive or motor, to alert people that surfaces may reach dangerous temperatures.



**ARC FLASH HAZARD:** Labels may be on or inside the equipment, for example, a motor control center, to alert people to potential Arc Flash. Arc Flash will cause severe injury or death. Wear proper Personal Protective Equipment (PPE). Follow ALL Regulatory requirements for safe work practices and for Personal Protective Equipment (PPE).

---

### IMPORTANT

Identifies information that is critical for successful application and understanding of the product.

---

Read this preface to familiarize yourself with the rest of the manual. It provides information concerning:

- who should use this manual
- the purpose of this manual
- related documentation

## Who Should Use this Manual

Use this manual if you are responsible for designing, installing, programming, or troubleshooting control systems that use Micro800™ controllers.

You should have a basic understanding of electrical circuitry and familiarity with relay logic. If you do not, obtain the proper training before using this product.

## Purpose of this Manual

This manual is a reference guide for Micro800 controllers, plug-in modules and accessories. It describes the procedures you use to install, wire, and troubleshoot your controller. This manual:

- explains how to install and wire your controllers
- gives you an overview of the Micro800 controller system

Refer to the Online Help provided with Connected Components Workbench™ software for more information on programming your Micro800 controller.

## Additional Resources

These documents contain additional information concerning related Rockwell Automation products.

Resource	Description
Micro800 Programmable Controller External AC Power Supply Installation <a href="#">2080-IN001</a>	Information on mounting and wiring the optional external power supply.
Micro810 USB Adapter Plug-in Module Wiring Diagrams <a href="#">2080-WD001</a>	Information on mounting and wiring the Micro810 USB Adapter Plug-in Module.
Micro800 1.5" LCD Display and Keypad Module Wiring Diagrams <a href="#">2080-WD009</a>	Information on mounting and wiring the Micro800 1.5" LCD Display and Keypad Module.
Micro800 Programmable Controllers General Instructions <a href="#">2080-RM001</a>	Information on instruction sets for developing programs for use in Micro800 control systems.
Industrial Automation Wiring and Grounding Guidelines, publication <a href="#">1770-4.1</a>	Provides general guidelines for installing a Rockwell Automation industrial system.
Product Certifications website, <a href="http://www.rockwellautomation.com/products/certification/">http://www.rockwellautomation.com/products/certification/</a>	Provides declarations of conformity, certificates, and other certification details.

<b>Resource</b>	<b>Description</b>
Application Considerations for Solid-State Controls <a href="#">SG-1.1</a>	A description of important differences between solid-state programmable controller products and hard-wired electromechanical devices.
National Electrical Code - Published by the National Fire Protection Association of Boston, MA.	An article on wire sizes and types for grounding electrical equipment.
Allen-Bradley Industrial Automation Glossary <a href="#">AG-7.1</a>	A glossary of industrial automation terms and abbreviations.

You can view or download publications at <http://www.rockwellautomation.com/literature/>. To order paper copies of technical documentation, contact your local Rockwell Automation distributor or sales representative.

You can download the latest version of Connected Components Workbench for your Micro800 at the URL below.  
<http://www.rockwellautomation.com/global/products-technologies/connected-components/>.

<b>Preface</b>	Who Should Use this Manual . . . . .	iii
	Purpose of this Manual . . . . .	iii
	Additional Resources . . . . .	iii
	 <b>Chapter 1</b>	
<b>Hardware Overview</b>	Hardware Features . . . . .	1
	Micro810 12-Point Controllers. . . . .	1
	 <b>Chapter 2</b>	
<b>About Your Controller</b>	Programming Software for Micro800 Controllers. . . . .	3
	Obtain Connected Components Workbench. . . . .	3
	Use Connected Components Workbench . . . . .	3
	Agency Certifications. . . . .	3
	Compliance to European Union Directives. . . . .	3
	EMC Directive. . . . .	4
	Low Voltage Directive . . . . .	4
	Installation Considerations . . . . .	4
	Environment and Enclosure . . . . .	6
	Preventing Electrostatic Discharge . . . . .	6
	Safety Considerations . . . . .	6
	North American Hazardous Location Approval. . . . .	7
	Disconnecting Main Power. . . . .	7
	Safety Circuits . . . . .	8
	Power Distribution . . . . .	8
	Periodic Tests of Master Control Relay Circuit . . . . .	8
	Power Considerations . . . . .	9
	Isolation Transformers. . . . .	9
	Power Supply Inrush. . . . .	9
	Loss of Power Source . . . . .	9
	Input States on Power Down . . . . .	10
	Other Types of Line Conditions. . . . .	10
	Preventing Excessive Heat . . . . .	10
	Master Control Relay. . . . .	10
	Using Emergency-Stop Switches . . . . .	11
	Schematic (Using IEC Symbols) . . . . .	13
	Schematic (Using ANSI/CSA Symbols). . . . .	14
	 <b>Chapter 3</b>	
<b>Install Your Controller</b>	Controller Mounting Dimensions . . . . .	15
	Mounting Dimensions. . . . .	15
	Module Spacing . . . . .	15
	DIN Rail Mounting . . . . .	15

	Panel Mounting .....	16
	<b>Chapter 4</b>	
<b>Wire Your Controller</b>	Wiring Requirements .....	17
	Use Surge Suppressors .....	17
	Recommended Surge Suppressors .....	19
	Ground the Controller .....	20
	Wiring Diagrams .....	20
	Controller I/O Wiring .....	21
	Minimize Electrical Noise .....	21
	Analog Channel Wiring Guidelines .....	22
	Minimize Electrical Noise on Analog Channels .....	22
	Ground Your Analog Cable .....	23
	Wiring Examples .....	23
	<b>Chapter 5</b>	
<b>Troubleshooting</b>	Status Indicators on the Controller .....	25
	Micro810 Controllers .....	25
	Status Indicators on the LCD Module .....	25
	Error codes .....	26
	Fault Types .....	26
	Corrective Action for Recoverable and Non-recoverable Faults ...	34
	Controller Fault Recovery Model .....	35
	Calling Rockwell Automation for Assistance .....	36
	<b>Chapter 6</b>	
<b>Program Execution in Micro800</b>	Configure and Program Your Micro810 Controller .....	37
	Overview of Program Execution .....	37
	Execution Rules .....	38
	Power Up and First Scan .....	39
	Periodic Execution of Programs .....	40
	Memory Allocation .....	40
	Guidelines and Limitations .....	41
	<b>Chapter 7</b>	
<b>Controller Security</b>	Exclusive Access .....	43
	Password Protection .....	43
	Compatibility .....	44
	Work with a Locked Controller .....	44
	Upload from a Password-Protected Controller .....	45
	Debug a Password-Protected Controller .....	45

Download to a Password-Protected Controller.....	45
Transfer Controller Program and Lock Receiving Controller.....	45
Back Up and Restore a Password-Protected Controller .....	46
Configure Controller Password .....	47
Recover from a Lost Password.....	47

## Appendix A

### Specifications

Micro810 Controllers .....	49
Micro800 Programmable Controller External AC Power Supply .	56

## Appendix B

### About Accessories

Accessories .....	57
External AC Power Supply.....	57
1.5" LCD Display and Keypad Module.....	58
USB Adapter.....	60

## Appendix C

### Quickstarts

Configure LCD Password .....	61
Activate Password .....	62
Deactivate Password .....	62
Change Password.....	63
Delete Password .....	64
Configure Controller Password .....	66
Set Controller Password .....	66
Change Password.....	68
Clear Password.....	69
Use the Micro810 Smart Relay Functionality .....	70
Smart Relay Block Execution Order.....	70
Navigate the LCD Display .....	71
Configure Count-Up (CTU) .....	71
Test the CTU Predefined Function .....	73
Configure On-delay Timing (TON) .....	77
Test the TON Predefined Function.....	78
Configure DOY.....	79
Test the DOY Predefined Function.....	81
Configure TOW .....	83
Test the TOW Predefined Function .....	85
Configure Countdown (CTD) .....	87
Test the CTD Predefined Function .....	88
Configure TONOFF .....	90
Test the TONOFF Predefined Function .....	92
Configure Pulse Timing (TP) .....	93

Test the TP Predefined Function ..... 94  
Configure TOF ..... 95  
Test the TOF Predefined Function..... 96  
Flash Update the  
Micro800 Firmware ..... 98  
Establish Communication Between RSLinx and a Micro810 12-point  
controller through USB..... 101  
Forcing I/O ..... 103  
    Check if Forces (locks) are Enabled..... 103  
    I/O Forces After a Power Cycle..... 104

**Appendix D**

**IPID Function Block**

How to AutoTune ..... 108  
    How Autotune Works ..... 109  
Troubleshooting an Autotune Process..... 109  
PID Application Example ..... 110  
    PID Code Sample ..... 112

**Index**

..... 115



## Hardware Overview

### Hardware Features

The Micro810 12-pt controllers are smart relays with high current relay output models and can be configured through the embedded LCD display without programming software. It can also function as a micro PLC with the same programming capabilities as the other Micro800 controllers.

Micro810 controllers do not support Micro800 plug-in modules, but do support a USB adapter, and an LCD module, which can be used as a backup memory module.

24V DC powered controllers accommodate any 24V DC output power supply that meets minimum specifications such as the optional Micro800 power supply (2080-LC10-12QWB, 2080-LC10-12QBB only).

### Micro810 12-Point Controllers

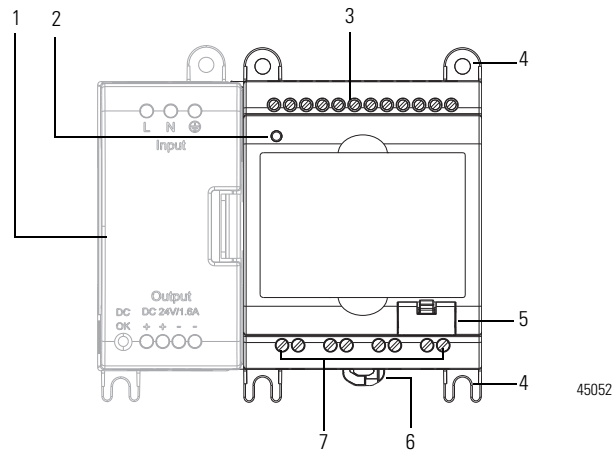

#### Controller Description

	Description		Description
1	Optional power supply	5	USB port (for use with USB Adapter only)
2	Status indicator	6	DIN rail mounting latch
3	Input terminal block	7	Output terminal block
4	Mounting screw hole/ mounting foot		

**Status Indicator**

State	During Normal Operation	During Firmware Update or Program/Data Transfer
Off	No power applied to device, or in Fault mode	No power applied to device, or in Fault mode
Solid green	Device operating normally	Program transfer successful
Flashing green	Operating System error	Firmware update in progress

**Micro810 Controllers**

Catalog Number	Power	Inputs			Outputs		Analog In 0...10V (shared with DC In)
		120V AC	240V AC	12...24V DC /V AC	Relay	24 V DC SRC	
2080-LC10-12QWB	24V DC			8	4		4
2080-LC10-12AWA	120...240V AC	8			4		
2080-LC10-12QBB	12...24V DC			8		4	4
2080-LC10-12DWD	12V DC			8	4		4

## About Your Controller

### Programming Software for Micro800 Controllers

Connected Components Workbench is a set of collaborative tools supporting Micro800 controllers. It is based on Rockwell Automation and Microsoft Visual Studio technology and offers controller programming, device configuration and integration with HMI editor. Use this software to program your controllers, configure your devices and design your operator interface applications.

Connected Components Workbench provides a choice of IEC 61131-3 programming languages (ladder diagram, function block diagram, structured text) with user defined function block support that optimizes machine control.

### Obtain Connected Components Workbench

A free download is available at:

<http://www.rockwellautomation.com/global/products-technologies/connected-components/>.

### Use Connected Components Workbench

To help you program your controller through the Connected Components Workbench software, you can refer to the Connected Components Workbench Online Help (it comes with your software).

### Agency Certifications

- UL Listed Industrial Control Equipment, certified for US and Canada. UL Listed for Class I, Division 2 Group A,B,C,D Hazardous Locations, certified for U.S. and Canada.
- CE marked for all applicable directives
- C-Tick marked for all applicable acts

### Compliance to European Union Directives

This product has the CE mark and is approved for installation within the European Union and EEA regions. It has been designed and tested to meet the following directives.

## EMC Directive

This product is tested to meet Council Directive 2004/108/EC Electromagnetic Compatibility (EMC) and the following standards, in whole or in part, documented in a technical construction file:

- EN 61131-2; Programmable Controllers (Clause 8, Zone A & B)
- EN 61131-2; Programmable Controllers (Clause 11)
- EN 61000-6-4  
EMC - Part 6-4: Generic Standards - Emission Standard for Industrial Environments
- EN 61000-6-2  
EMC - Part 6-2: Generic Standards - Immunity for Industrial Environments

This product is intended for use in an industrial environment.

## Low Voltage Directive

This product is tested to meet Council Directive 2006/95/EC Low Voltage, by applying the safety requirements of EN 61131-2 Programmable Controllers, Part 2 - Equipment Requirements and Tests.

For specific information required by EN 61131-2, see the appropriate sections in this publication, as well as the following Allen-Bradley publications:

- Industrial Automation Wiring and Grounding Guidelines for Noise Immunity, publication [1770-4.1](#)

## Installation Considerations

Most applications require installation in an industrial enclosure (Pollution Degree 2<sup>(1)</sup>) to reduce the effects of electrical interference (Over Voltage Category II<sup>(2)</sup>) and environmental exposure. Locate your controller as far as possible from power lines, load lines, and other sources of electrical noise such as hard-contact switches, relays, and AC motor drives. For more information on proper grounding guidelines, see the Industrial Automation Wiring and Grounding Guidelines publication [1770-4.1](#).

(1) Pollution Degree 2 is an environment where normally only non-conductive pollution occurs except that occasionally temporary conductivity caused by condensation shall be expected.

(2) Overvoltage Category II is the load level section of the electrical distribution system. At this level, transient voltages are controlled and do not exceed the impulse voltage capability of the products insulation.



**WARNING:** If you insert or remove the module while power is on, an electrical arc can occur. This could cause an explosion in hazardous location installations.

Be sure that power is removed or the area is nonhazardous before proceeding.

**WARNING:** The local programming terminal port is intended for temporary use only and must not be connected or disconnected unless the area is assured to be nonhazardous.

**WARNING:** When used in a Class I, Division 2, hazardous location, this equipment must be mounted in a suitable enclosure with proper wiring method that complies with the governing electrical codes.

**WARNING:** If you connect or disconnect wiring while the field-side power is on, an electrical arc can occur. This could cause an explosion in hazardous location installations. Be sure that power is removed or the area is nonhazardous before proceeding.

**WARNING:** The USB port is intended for temporary local programming purposes only and not intended for permanent connection. If you connect or disconnect the USB cable with power applied to this module or any device on the USB network, an electrical arc can occur. This could cause an explosion in hazardous location installations.

Be sure that power is removed or the area is nonhazardous before proceeding.

The USB port is a nonincendive field wiring connection for Class I, Division 2 Groups A, B, C and D.

**WARNING:** Exposure to some chemicals may degrade the sealing properties of materials used in the Relays. It is recommended that the User periodically inspect these devices for any degradation of properties and replace the module if degradation is found.

**WARNING:** To comply with the CE Low Voltage Directive (LVD), this equipment must be powered from a source compliant with the following:

Safety Extra Low Voltage (SELV) or Protected Extra Low Voltage (PELV).

**WARNING:** To comply with UL restrictions, this equipment must be powered from a source compliant with the following:

Class 2 or Limited Voltage/Current.

**WARNING:** Do not wire more than 2 conductors on any single terminal.

**WARNING:** Be careful when stripping wires. Wire fragments that fall into the controller could cause damage. Once wiring is complete, make sure the controller is free of all metal fragments.

---



**ATTENTION:** Do not remove the protective debris strips until after the controller and all other equipment in the panel near the module are mounted and wired. Remove strips before operating the controller. Failure to remove strips before operating can cause overheating.

**ATTENTION:** Electrostatic discharge can damage semiconductor devices inside the module. Do not touch the connector pins or other sensitive areas.

**ATTENTION:** This product is intended to be mounted to a well-grounded mounting surface such as a metal panel. Additional grounding connections from the power supply's mounting tabs or DIN rail (if used) are not required unless the mounting surface cannot be grounded. Refer to Industrial Automation Wiring and Grounding Guidelines, Allen-Bradley publication [1770-4.1](#), for additional information.

**ATTENTION:** The USB cable is not to exceed 3.0 m (9.84 ft).

---

## Environment and Enclosure

---



This equipment is intended for use in a Pollution Degree 2 industrial environment, in overvoltage Category II applications (as defined in IEC 60664-1), at altitudes up to 2000 m (6562 ft) without derating.

This equipment is considered Group 1, Class A industrial equipment according to IEC/CISPR 11. Without appropriate precautions, there may be difficulties with electromagnetic compatibility in residential and other environments due to conducted and radiated disturbances.

This equipment is supplied as open-type equipment. It must be mounted within an enclosure that is suitably designed for those specific environmental conditions that will be present and appropriately designed to prevent personal injury resulting from accessibility to live parts. The enclosure must have suitable flame-retardant properties to prevent or minimize the spread of flame, complying with a flame spread rating of 5VA, V2, V1, V0 (or equivalent) if non-metallic. The interior of the enclosure must be accessible only by the use of a tool. Subsequent sections of this publication may contain additional information regarding specific enclosure type ratings that are required to comply with certain product safety certifications.

In addition to this publication, see:

- Industrial Automation Wiring and Grounding Guidelines, Rockwell Automation publication [1770-4.1](#), for additional installation requirements.
- NEMA Standard 250 and IEC 60529, as applicable, for explanations of the degrees of protection provided by different types of enclosure.

---

## Preventing Electrostatic Discharge

---





This equipment is sensitive to electrostatic discharge, which can cause internal damage and affect normal operation. Follow these guidelines when you handle this equipment:

- Touch a grounded object to discharge potential static.
  - Wear an approved grounding wriststrap.
  - Do not touch connectors or pins on component boards.
  - Do not touch circuit components inside the equipment.
  - Use a static-safe workstation, if available.
  - Store the equipment in appropriate static-safe packaging when not in use.
- 

## Safety Considerations

Safety considerations are an important element of proper system installation. Actively thinking about the safety of yourself and others, as well as the condition of your equipment, is of primary importance. We recommend reviewing the following safety considerations.

## North American Hazardous Location Approval

The following information applies when operating this equipment in hazardous locations:	Informations sur l'utilisation de cet équipement en environnements dangereux:
<p>Products marked "CL I, DIV 2, GP A, B, C, D" are suitable for use in Class I Division 2 Groups A, B, C, D, Hazardous Locations and nonhazardous locations only. Each product is supplied with markings on the rating nameplate indicating the hazardous location temperature code. When combining products within a system, the most adverse temperature code (lowest "T" number) may be used to help determine the overall temperature code of the system. Combinations of equipment in your system are subject to investigation by the local Authority Having Jurisdiction at the time of installation.</p>	<p>Les produits marqués "CL I, DIV 2, GP A, B, C, D" ne conviennent qu'à une utilisation en environnements de Classe I Division 2 Groupes A, B, C, D dangereux et non dangereux. Chaque produit est livré avec des marquages sur sa plaque d'identification qui indiquent le code de température pour les environnements dangereux. Lorsque plusieurs produits sont combinés dans un système, le code de température le plus défavorable (code de température le plus faible) peut être utilisé pour déterminer le code de température global du système. Les combinaisons d'équipements dans le système sont sujettes à inspection par les autorités locales qualifiées au moment de l'installation.</p>
<div style="display: flex; align-items: center;">  <div> <p><b>EXPLOSION HAZARD</b></p> <ul style="list-style-type: none"> <li>Do not disconnect equipment unless power has been removed or the area is known to be nonhazardous.</li> <li>Do not disconnect connections to this equipment unless power has been removed or the area is known to be nonhazardous. Secure any external connections that mate to this equipment by using screws, sliding latches, threaded connectors, or other means provided with this product.</li> <li>Substitution of any component may impair suitability for Class I, Division 2.</li> <li>If this product contains batteries, they must only be changed in an area known to be nonhazardous.</li> </ul> </div> </div>	<div style="display: flex; align-items: center;">  <div> <p><b>RISQUE D'EXPLOSION</b></p> <ul style="list-style-type: none"> <li>Couper le courant ou s'assurer que l'environnement est classé non dangereux avant de débrancher l'équipement.</li> <li>Couper le courant ou s'assurer que l'environnement est classé non dangereux avant de débrancher les connecteurs. Fixer tous les connecteurs externes reliés à cet équipement à l'aide de vis, loquets coulissants, connecteurs filetés ou autres moyens fournis avec ce produit.</li> <li>La substitution de tout composant peut rendre cet équipement inadapté à une utilisation en environnement de Classe I, Division 2.</li> <li>S'assurer que l'environnement est classé non dangereux avant de changer les piles.</li> </ul> </div> </div>

### Disconnecting Main Power



**WARNING: Explosion Hazard**

Do not replace components, connect equipment, or disconnect equipment unless power has been switched off.

The main power disconnect switch should be located where operators and maintenance personnel have quick and easy access to it. In addition to disconnecting electrical power, all other sources of power (pneumatic and hydraulic) should be de-energized before working on a machine or process controlled by a controller.

## Safety Circuits



**WARNING:** Explosion Hazard  
Do not connect or disconnect connectors while circuit is live.

---

Circuits installed on the machine for safety reasons, like overtravel limit switches, stop push buttons, and interlocks, should always be hard-wired directly to the master control relay. These devices must be wired in series so that when any one device opens, the master control relay is de-energized, thereby removing power to the machine. Never alter these circuits to defeat their function. Serious injury or machine damage could result.

## Power Distribution

There are some points about power distribution that you should know:

- The master control relay must be able to inhibit all machine motion by removing power to the machine I/O devices when the relay is de-energized. It is recommended that the controller remain powered even when the master control relay is de-energized.
- If you are using a DC power supply, interrupt the load side rather than the AC line power. This avoids the additional delay of power supply turn-off. The DC power supply should be powered directly from the fused secondary of the transformer. Power to the DC input and output circuits should be connected through a set of master control relay contacts.

## Periodic Tests of Master Control Relay Circuit

Any part can fail, including the switches in a master control relay circuit. The failure of one of these switches would most likely cause an open circuit, which would be a safe power-off failure. However, if one of these switches shorts out, it no longer provides any safety protection. These switches should be tested periodically to assure they will stop machine motion when needed.



## Power Considerations

The following explains power considerations for the micro controllers.

### Isolation Transformers

You may want to use an isolation transformer in the AC line to the controller. This type of transformer provides isolation from your power distribution system to reduce the electrical noise that enters the controller and is often used as a step-down transformer to reduce line voltage. Any transformer used with the controller must have a sufficient power rating for its load. The power rating is expressed in volt-amperes (VA).

### Power Supply Inrush

During power-up, the Micro800 power supply allows a brief inrush current to charge internal capacitors. Many power lines and control transformers can supply inrush current for a brief time. If the power source cannot supply this inrush current, the source voltage may sag momentarily.

The only effect of limited inrush current and voltage sag on the Micro800 is that the power supply capacitors charge more slowly. However, the effect of a voltage sag on other equipment should be considered. For example, a deep voltage sag may reset a computer connected to the same power source. The following considerations determine whether the power source must be required to supply high inrush current:

- The power-up sequence of devices in a system.
- The amount of the power source voltage sag if the inrush current cannot be supplied.
- The effect of voltage sag on other equipment in the system.

If the entire system is powered-up at the same time, a brief sag in the power source voltage typically will not affect any equipment.

### Loss of Power Source

The optional Micro800 AC power supply is designed to withstand brief power losses without affecting the operation of the system. The time the system is operational during power loss is called program scan hold-up time after loss of power. The duration of the power supply hold-up time depends on power consumption of controller system, but is typically between 10 milliseconds and 3 seconds.

## Input States on Power Down

The power supply hold-up time as described above is generally longer than the turn-on and turn-off times of the inputs. Because of this, the input state change from “On” to “Off” that occurs when power is removed may be recorded by the processor before the power supply shuts down the system. Understanding this concept is important. The user program should be written to take this effect into account.

## Other Types of Line Conditions

Occasionally the power source to the system can be temporarily interrupted. It is also possible that the voltage level may drop substantially below the normal line voltage range for a period of time. Both of these conditions are considered to be a loss of power for the system.

## Preventing Excessive Heat

For most applications, normal convective cooling keeps the controller within the specified operating range. Ensure that the specified temperature range is maintained. Proper spacing of components within an enclosure is usually sufficient for heat dissipation.

In some applications, a substantial amount of heat is produced by other equipment inside or outside the enclosure. In this case, place blower fans inside the enclosure to assist in air circulation and to reduce “hot spots” near the controller.

Additional cooling provisions might be necessary when high ambient temperatures are encountered.

**TIP** Do not bring in unfiltered outside air. Place the controller in an enclosure to protect it from a corrosive atmosphere. Harmful contaminants or dirt could cause improper operation or damage to components. In extreme cases, you may need to use air conditioning to protect against heat build-up within the enclosure.

## Master Control Relay

A hard-wired master control relay (MCR) provides a reliable means for emergency machine shutdown. Since the master control relay allows the placement of several emergency-stop switches in different locations, its installation is important from a safety standpoint. Overtravel limit switches or mushroom-head push buttons are wired in series so that when any of them opens, the master control relay is de-energized. This removes power to input and output device circuits. Refer to the figures on pages 13 and 14.



**WARNING:** Never alter these circuits to defeat their function since serious injury and/or machine damage could result.

**TIP** If you are using an external DC power supply, interrupt the DC output side rather than the AC line side of the supply to avoid the additional delay of power supply turn-off.

The AC line of the DC output power supply should be fused.

Connect a set of master control relays in series with the DC power supplying the input and output circuits.

Place the main power disconnect switch where operators and maintenance personnel have quick and easy access to it. If you mount a disconnect switch inside the controller enclosure, place the switch operating handle on the outside of the enclosure, so that you can disconnect power without opening the enclosure.

Whenever any of the emergency-stop switches are opened, power to input and output devices should be removed.

When you use the master control relay to remove power from the external I/O circuits, power continues to be provided to the controller's power supply so that diagnostic indicators on the processor can still be observed.

The master control relay is not a substitute for a disconnect to the controller. It is intended for any situation where the operator must quickly de-energize I/O devices only. When inspecting or installing terminal connections, replacing output fuses, or working on equipment within the enclosure, use the disconnect to shut off power to the rest of the system.

**TIP** Do not control the master control relay with the controller. Provide the operator with the safety of a direct connection between an emergency-stop switch and the master control relay.

## Using Emergency-Stop Switches

When using emergency-stop switches, adhere to the following points:

- Do not program emergency-stop switches in the controller program. Any emergency-stop switch should turn off all machine power by turning off the master control relay.
- Observe all applicable local codes concerning the placement and labeling of emergency-stop switches.

- Install emergency-stop switches and the master control relay in your system. Make certain that relay contacts have a sufficient rating for your application. Emergency-stop switches must be easy to reach.
- In the following illustration, input and output circuits are shown with MCR protection. However, in most applications, only output circuits require MCR protection.

The following illustrations show the Master Control Relay wired in a grounded system.

**TIP** In most applications input circuits do not require MCR protection; however, if you need to remove power from all field devices, you must include MCR contacts in series with input power wiring.

### Schematic (Using IEC Symbols)

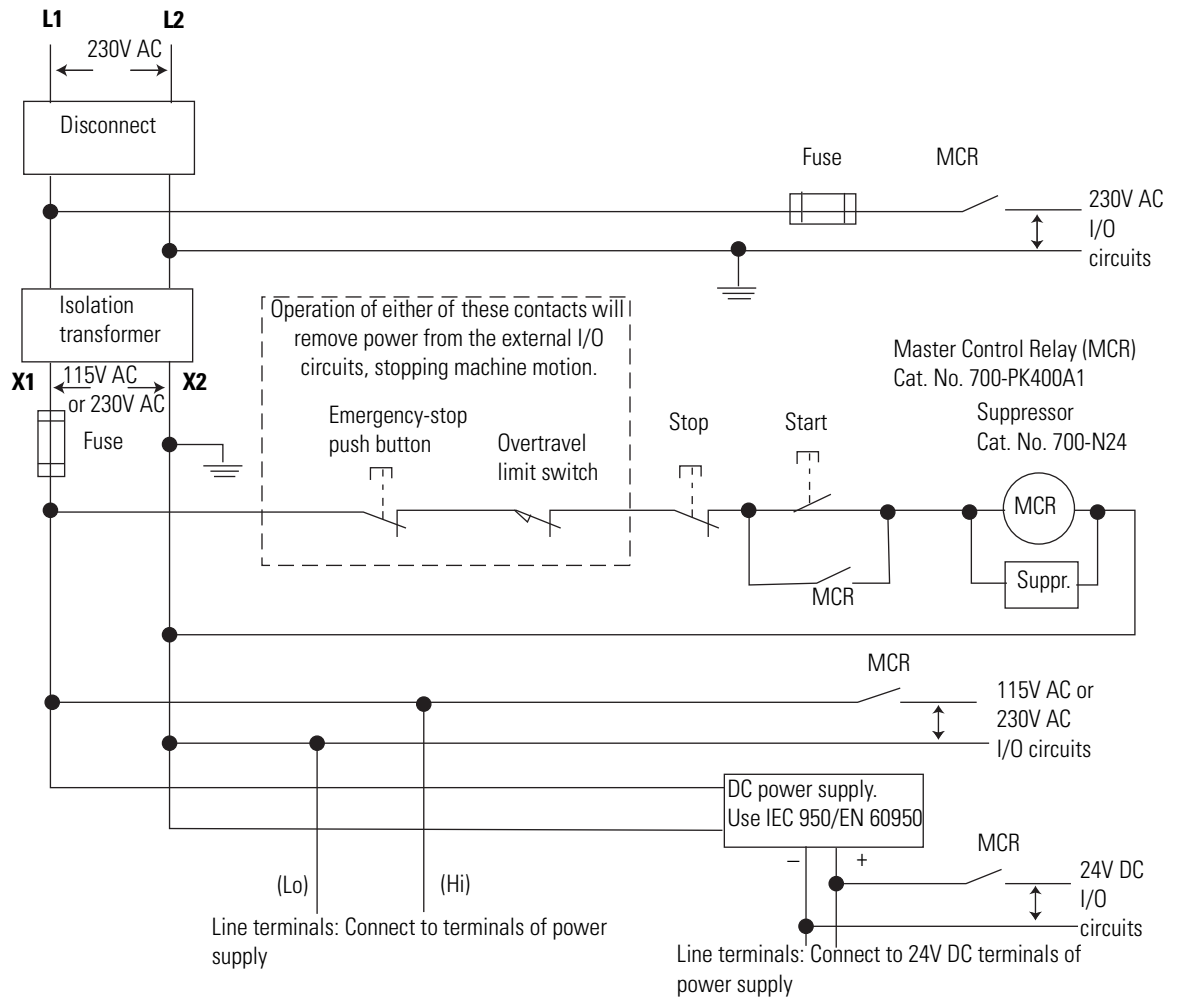

44564

### Schematic (Using ANSI/CSA Symbols)

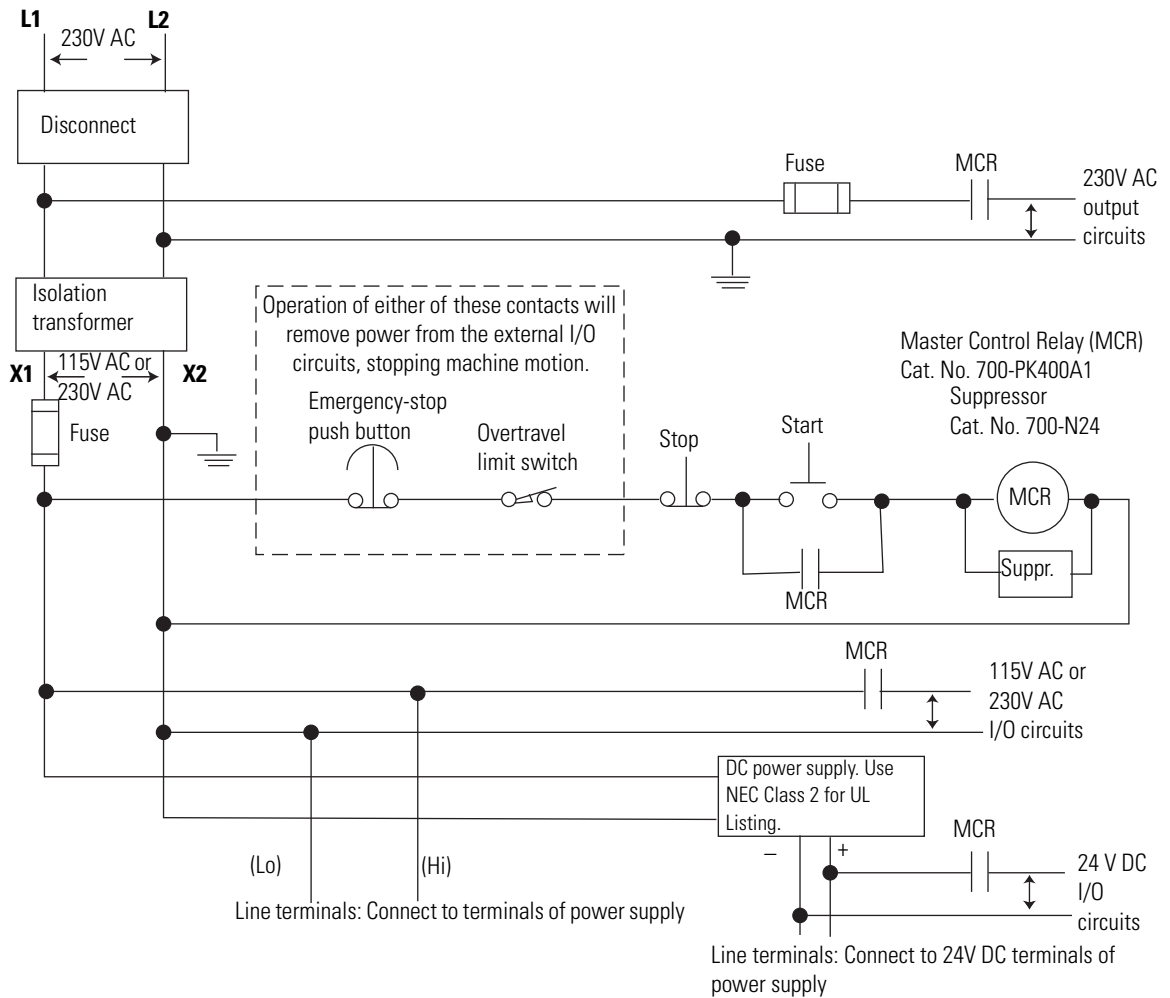

44565

## Install Your Controller

### Controller Mounting Dimensions

### Mounting Dimensions

Mounting dimensions do not include mounting feet or DIN rail latches.

#### *Micro810 Controllers*

*2080-LC10-12AWA, 2080-LC10-12QWB, 2080-LC10-12QBB, 2080-LC10-12DWD*

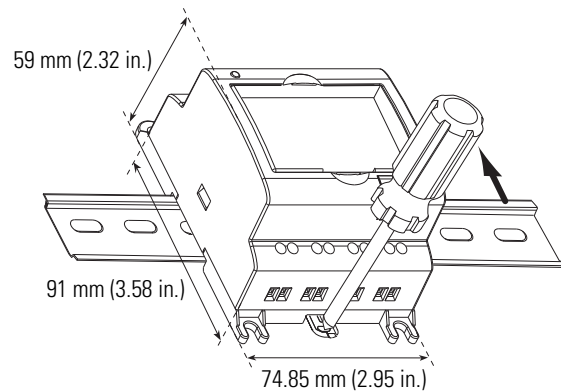

45054

### Module Spacing

Maintain spacing from objects such as enclosure walls, wireways and adjacent equipment. Allow 50.8 mm (2 in.) of space on all sides for adequate ventilation. An exception to this spacing guideline is allowed for the side at which you are connecting the optional power supply, 2080-PS120-240VAC.

### DIN Rail Mounting

The module can be mounted using the following DIN rails: 35 x 7.5 mm x 1 mm (EN 50 022 - 35 x 7.5).

**TIP** For environments with greater vibration and shock concerns, use the panel mounting method, instead of DIN rail mounting.

Before mounting the module on a DIN rail, use a flat-blade screwdriver in the DIN rail latch and pry it downwards until it is in the unlatched position.

1. Hook the top of the DIN rail mounting area of the controller onto the DIN rail, and then press the bottom until the controller snaps onto the DIN rail.
2. Push the DIN rail latch back into the latched position.  
Use DIN rail end anchors (Allen-Bradley part number 1492-EAJ35 or 1492-EAHJ35) for vibration or shock environments.

To remove your controller from the DIN rail, pry the DIN rail latch downwards until it is in the unlatched position.

## **Panel Mounting**

The preferred mounting method is to use four M4 (#8) screws per module. Hole spacing tolerance:  $\pm 0.4$  mm (0.016 in.).

Follow these steps to install your controller using mounting screws.

1. Place the controller against the panel where you are mounting it. Make sure the controller is spaced properly.
2. Mark drilling holes through the mounting screw holes and mounting feet then remove the controller.
3. Drill the holes at the markings, then replace the controller and mount it. Leave the protective debris strip in place until you are finished wiring the controller and any other devices.



# Wire Your Controller

## Wiring Requirements



**WARNING:** Before you install and wire any device, disconnect power to the controller system.



**WARNING:** Calculate the maximum possible current in each power and common wire. Observe all electrical codes dictating the maximum current allowable for each wire size. Current above the maximum ratings may cause wiring to overheat, which can cause damage. *United States Only.* If the controller is installed within a potentially hazardous environment, all wiring must comply with the requirements stated in the National Electrical Code 501-10 (b).

- Allow for at least 50 mm. (2 in.) between I/O wiring ducts or terminal strips and the controller.
- Route incoming power to the controller by a path separate from the device wiring. Where paths must cross, their intersection should be perpendicular.

**TIP** Do not run signal or communications wiring and power wiring in the same conduit. Wires with different signal characteristics should be routed by separate paths.

- Separate wiring by signal type. Bundle wiring with similar electrical characteristics together.
- Separate input wiring from output wiring.
- Label wiring to all devices in the system. Use tape, shrink-tubing, or other dependable means for labeling purposes. In addition to labeling, use colored insulation to identify wiring based on signal characteristics. For example, you may use blue for DC wiring and red for AC wiring.

### Wire Requirements

	Wire Size
Micro810 Controllers	0.32... 2.1 mm <sup>2</sup> (22...14 AWG) solid copper wire or 0.32... 1.3 mm <sup>2</sup> (22...16 AWG) stranded copper wire rated at 90 °C (194 °F) insulation max.

## Use Surge Suppressors

Because of the potentially high current surges that occur when switching inductive load devices, such as motor starters and solenoids, the use of some type

of surge suppression to protect and extend the operating life of the controllers output contacts is required. Switching inductive loads without surge suppression can *significantly* reduce the life expectancy of relay contacts. By adding a suppression device directly across the coil of an inductive device, you prolong the life of the output or relay contacts. You also reduce the effects of voltage transients and electrical noise from radiating into adjacent systems.

The following diagram shows a typical PLC's output with a suppression device. We recommend that you locate the suppression device as close as possible to the load device.

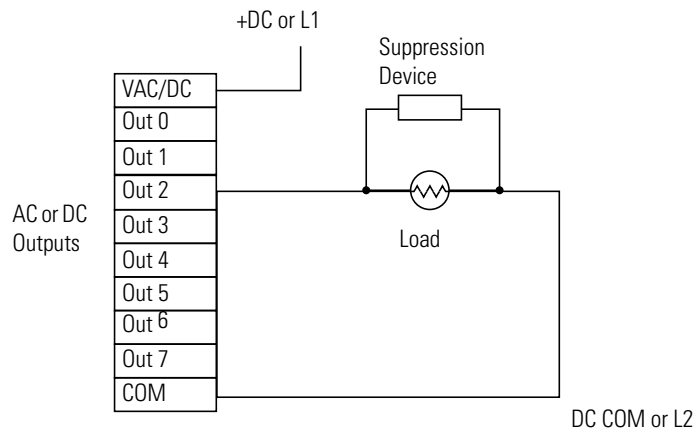

If the outputs are DC, we recommend that you use an 1N4004 diode for surge suppression, as shown below. For inductive DC load devices, a diode is suitable. A 1N4004 diode is acceptable for most applications. A surge suppressor can also be used. See [page 19](#) for recommended suppressors. As shown below with a typical PLC's output, these surge suppression circuits connect directly across the load device.

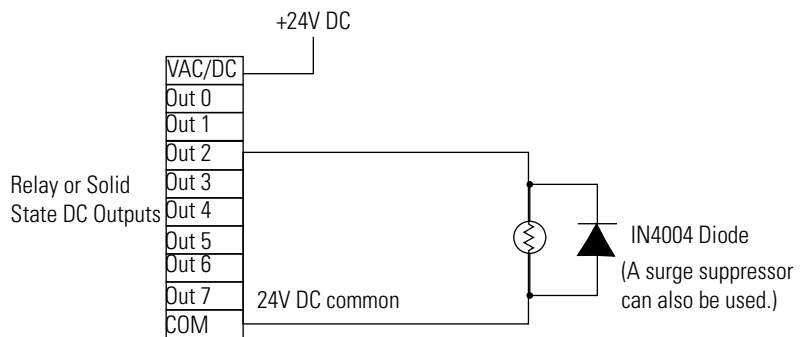

Suitable surge suppression methods for inductive AC load devices include a varistor, an RC network, or an Allen-Bradley surge suppressor, all shown below. These components must be appropriately rated to suppress the switching

transient characteristic of the particular inductive device. See Recommended Surge Suppressors on page 19 for recommended suppressors.

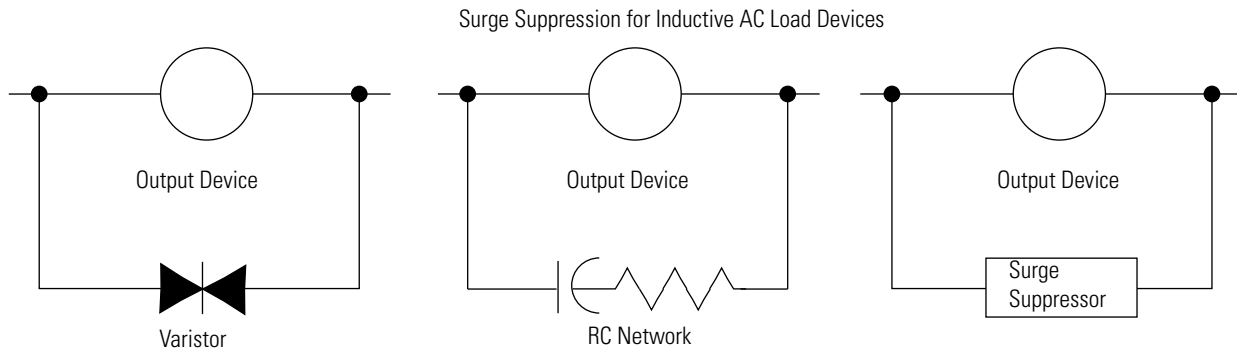

## Recommended Surge Suppressors

Use the Allen-Bradley surge suppressors shown in the following table for use with relays, contactors, and starters.

### Recommended Surge Suppressors

Device	Coil Voltage	Suppressor Catalog Number	Type <sup>(4)</sup>
Bulletin 100/104K 700K	24...48V AC	100-KFSC50	RC
	110...280V AC	100-KFSC280	
	380...480V AC	100-KFSC480	
	MOV	12...55 V AC, 12...77V DC	100-KFSV55
		56...136 VAC, 78...180V DC	100-KFSV136
		137...277V AC, 181...250 V DC	100-KFSV277
		12...250V DC	100-KFSD250
Bulletin 100C, (C09 - C97)	24...48V AC	100-FSC48 <sup>(1)</sup>	RC
	110...280V AC	100-FSC280 <sup>(1)</sup>	
	380...480V AC	100-FSC480 <sup>(1)</sup>	
	MOV	12...55V AC, 12...77V DC	100-FSV55 <sup>(1)</sup>
		56...136V AC, 78...180V DC	100-FSV136 <sup>(1)</sup>
		137...277V AC, 181...250V DC	100-FSV277 <sup>(1)</sup>
		278...575V AC	100-FSV575 <sup>(1)</sup>
		12...250V DC	100-FSD250 <sup>(1)</sup>
Bulletin 509 Motor Starter Size 0 - 5	12...120V AC	599-K04	MOV
	240...264V AC	599-KA04	

### Recommended Surge Suppressors

Device	Coil Voltage	Suppressor Catalog Number	Type <sup>(4)</sup>
Bulletin 509 Motor Starter Size 6	12...120V AC	199-FSMA1 <sup>(2)</sup>	RC
	12...120V AC	199-GSMA1 <sup>(3)</sup>	MOV
Bulletin 700 R/RM Relay	AC coil	Not Required	
	24...48V DC	199-FSMA9	MOV
	50...120V DC	199-FSMA10	
	130...250V DC	199-FSMA11	
Bulletin 700 Type N, P, PK or PH Relay	6...150V AC/DC	700-N24	RC
	24...48V AC/DC	199-FSMA9	MOV
	50...120V AC/DC	199-FSMA10	
	130...250V AC/DC	199-FSMA11	
	6...300V DC	199-FSMZ-1	Diode
Miscellaneous electromagnetic devices limited to 35 sealed VA	6...150V AC/DC	700-N24	RC

- (1) Catalog numbers for screwless terminals include the string 'CR' after '100-'. For example: Cat. No. 100-FSC48 becomes Cat. No. 100-**CR**FSC48; Cat. No. 100-FSV55 becomes 100-**CR**FSV55; and so on.
- (2) For use on the interposing relay.
- (3) For use on the contactor or starter.
- (4) RC Type not to be used with Triac outputs. Varistor is not recommended for use on the relay outputs.

## Ground the Controller

This product is intended to be mounted to a well grounded mounting surface such as a metal panel. Refer to the Industrial Automation Wiring and Grounding Guidelines, publication [1770-4.1](#), for additional information.

## Wiring Diagrams

The following illustrations show the wiring diagrams for the Micro800 controllers. For controllers with DC inputs, inputs 0...3 can be wired as either sinking or sourcing inputs, however, inputs 4...7 can only be wired as sinking inputs. Sinking and sourcing does not apply to AC inputs.

### Micro810 Controllers

#### 2080-LC10-12AWA

##### Input Terminal Block

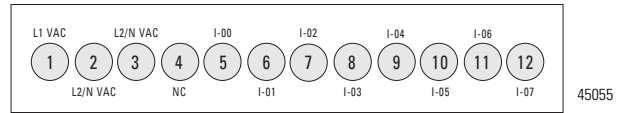

##### Output Terminal Block

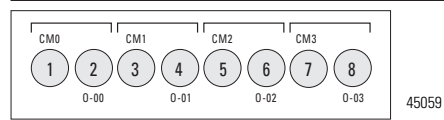

#### 2080-LC10-12QWB

##### Input Terminal Block<sup>(1)</sup>

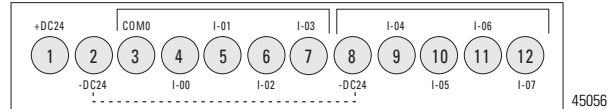

##### Output Terminal Block

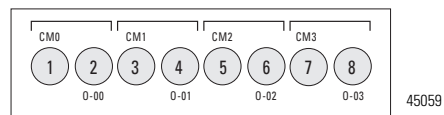

#### 2080-LC10-12DWD

##### Input Terminal Block<sup>(1)</sup>

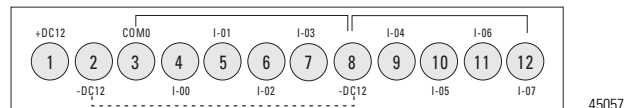

##### Output Terminal Block

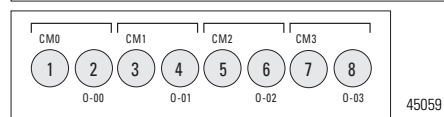

#### 2080-LC10-12QBB

##### Input Terminal Block<sup>(1)</sup>

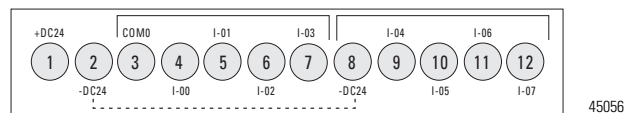

##### Output Terminal Block

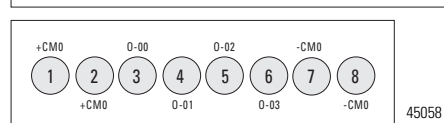

<sup>1</sup> I-04, I-05, I-06, I-07 apply as both digital inputs 4, 5, 6, 7 and analog inputs 0, 1, 2, 3 for the 2080-LC10-QWB, 2080-LC10-12DWD, and 2080-LC10-12QBB models.

## Controller I/O Wiring

### Minimize Electrical Noise

Because of the variety of applications and environments where controllers are installed and operating, it is impossible to ensure that all environmental noise will be removed by input filters. To help reduce the effects of environmental noise,

install the Micro800 system in a properly rated (for example, NEMA) enclosure. Make sure that the Micro800 system is properly grounded.

A system may malfunction due to a change in the operating environment after a period of time. We recommend periodically checking system operation, particularly when new machinery or other noise sources are installed near the Micro800 system.

## Analog Channel Wiring Guidelines

Consider the following when wiring your analog channels:

- The analog common (COM) is connected to power supply common inside the module. These terminals are not electrically isolated from the system.
- Analog channels are not isolated from each other.
- Use Belden 8761, or equivalent, shielded wire.
- Under normal conditions, the drain wire (shield) should be connected to the metal mounting panel at field side (earth ground). Keep the shield connection to earth ground as short as possible.
- To ensure optimum accuracy for voltage type inputs, limit overall cable impedance by keeping all analog cables as short as possible. Locate the I/O system as close to your voltage type sensors or actuators as possible.

## Minimize Electrical Noise on Analog Channels

Inputs on analog channels employ digital high-frequency filters that significantly reduce the effects of electrical noise on input signals. However, because of the variety of applications and environments where analog controllers are installed and operated, it is impossible to ensure that all environmental noise will be removed by the input filters.

Several specific steps can be taken to help reduce the effects of environmental noise on analog signals:

- install the Micro800 system in a properly rated enclosure, for example, NEMA. Make sure that the Micro800 system is properly grounded.
- use Belden cable #8761 for wiring the analog channels, making sure that the drain wire and foil shield are properly earth grounded.
- route the Belden cable separately from any AC wiring. Additional noise immunity can be obtained by routing the cables in grounded conduit.

## Ground Your Analog Cable

Use shielded communication cable (Belden #8761). The Belden cable has two signal wires (black and clear), one drain wire, and a foil shield. The drain wire and foil shield must be grounded at one end of the cable.

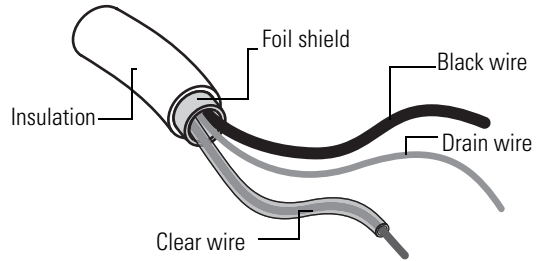

44531

---

**IMPORTANT** Ground the drain wire and foil shield at field side.

---

## Wiring Examples

Examples of sink/source, input/output wiring are shown below.

### Sink output wiring example

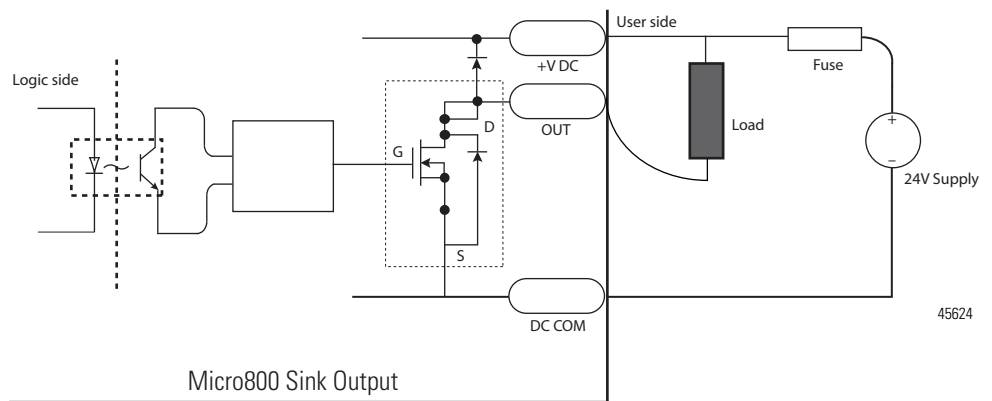

45624

Sink input wiring example

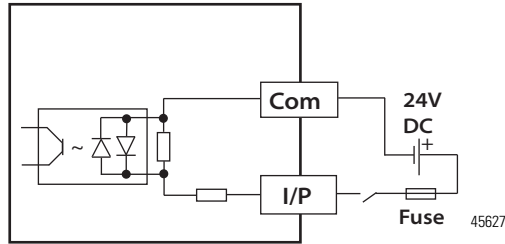

Source output wiring example

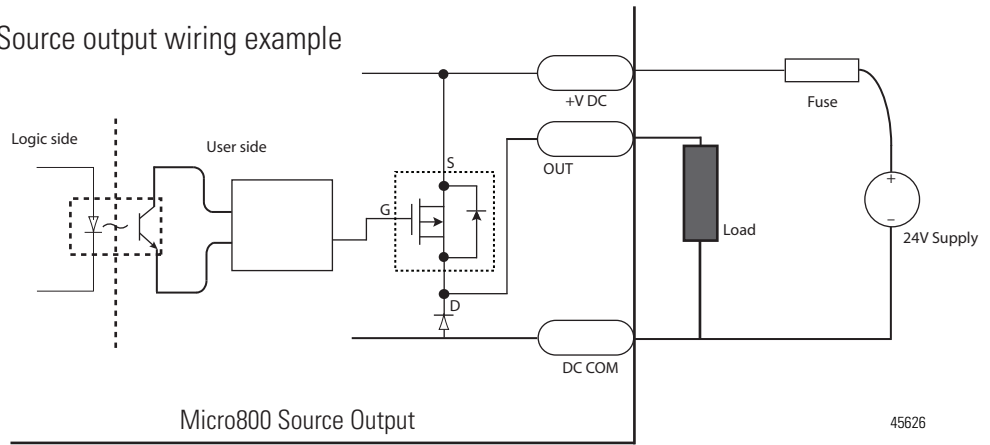

Source input wiring example

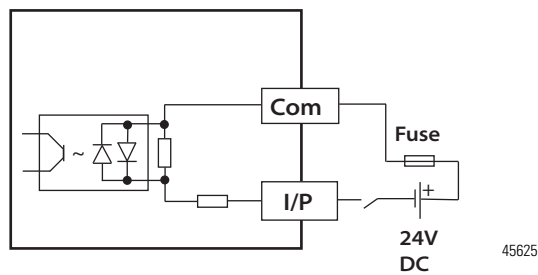



## Troubleshooting

### Status Indicators on the Controller

### Micro810 Controllers

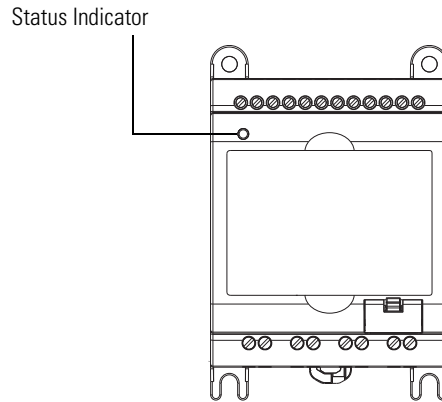

#### Status Indicator on the Controller

State	During Normal Operation	During Firmware Update or Program/Data Transfer
Off	No power applied to device, or in Fault mode	No power applied to device, or in Fault mode
Solid green	Device operating normally	Program transfer successful
Flashing green	Operating System error	Firmware update in progress

### Status Indicators on the LCD Module

If you are using the LCD module, you can see input and output status indicators on the LCD module.

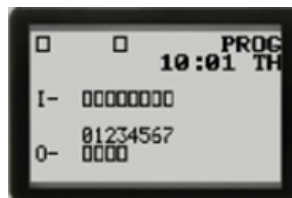

## Error codes

This section lists possible error codes for your controller, as well as recommended actions for recovery. Information about the fault is stored in a fault log, which can be accessed from the Diagnostics page in Connected Components Workbench software. The fault log contains brief information about the last fault, and detailed information about the last 10 non-recoverable faults that occurred.

If an error persists after performing the recommended action, contact your local Rockwell Automation technical support representative. For contact information, go to <http://support.rockwellautomation.com/MySupport.asp>.

## Fault Types

There are two basic types of faults that can occur:

- Recoverable – A recoverable fault can be cleared without having to power cycle the controller. The fault LED flashes red when a recoverable fault occurs.
- Non-recoverable – A non-recoverable fault requires the controller to be power cycled before clearing the fault. Non-recoverable controller faults may become recoverable after the controller has been power cycled, or an automatic reset is performed by the controller. If the controller performs an automatic reset and the fault becomes recoverable, the fault will not be logged. After the controller has been power cycled or reset, check the fault log in the Diagnostic page of the Connected Components Workbench software, then clear the fault. The fault LED is solid red when a non-recoverable fault occurs.

**List of Error Codes for Micro800 controllers**

<b>Error Code</b>	<b>Fault Type</b>	<b>Description</b>	<b>Recommended Action</b>
0xF000	Recoverable	The controller was unexpectedly reset due to a noisy environment or an internal hardware failure. If the system variable <code>_SYSVA_USER_DATA_LOST</code> is set, the controller is able to recover the user program but the user data is cleared. If not, the Micro800 controller program is cleared.	Perform one of the following: <ul style="list-style-type: none"> <li>• See <a href="#">Corrective Actions for Recoverable Faults on page 34</a>.</li> <li>• Check wiring to eliminate any noise, refer to <a href="#">Wiring Requirements and Recommendation on page 39</a>.</li> </ul>
0xF001	Recoverable	The controller program has been cleared. This happened because: <ul style="list-style-type: none"> <li>• a power-down occurred during program download or data transfer from the memory module</li> <li>• the cable was removed from the controller during program download.</li> <li>• the RAM integrity test failed.</li> </ul>	Perform one of the following: <ul style="list-style-type: none"> <li>• See <a href="#">Corrective Actions for Recoverable Faults on page 34</a>.</li> <li>• Transfer the program using the memory module restore utility.</li> </ul>
0xF002	Non-recoverable	The controller hardware watchdog was activated. The controller hardware watchdog timeout happens if program scan is more than three seconds. If the system variable <code>_SYSVA_USER_DATA_LOST</code> is set, the controller is able to recover the user program but the user data is cleared. If not, the Micro800 controller program is cleared.	See <a href="#">Corrective Actions for Non-recoverable Faults on page 34</a> .
0xF003	Recoverable	One of the following occurred: <ul style="list-style-type: none"> <li>• The memory module hardware faulted.</li> <li>• The memory module connection faulted.</li> <li>• The memory module was incompatible with the Micro800 controller's firmware revision.</li> </ul>	Perform one of the following: <ul style="list-style-type: none"> <li>• Remove the memory module and plug it in again.</li> <li>• Obtain a new memory module.</li> <li>• See <a href="#">Corrective Actions for Recoverable Faults on page 34</a>.</li> <li>• Upgrade the Micro800 controller's firmware revision to be compatible with the memory module. For more information on firmware revision compatibility, go to <a href="http://www.rockwellautomation.com/support/firmware.html">http://www.rockwellautomation.com/support/firmware.html</a></li> </ul>
0xF004	Recoverable	A failure occurred during the memory module data transfer.	Perform one of the following: <ul style="list-style-type: none"> <li>• See <a href="#">Corrective Actions for Recoverable Faults on page 34</a>.</li> <li>• Attempt the data transfer again. If the error persists, replace the memory module.</li> <li>• For Embedded RTC failure, restart the controller.</li> </ul>
0xF005	Recoverable	The user program failed an integrity check while the Micro800 controller was in Run mode.	Perform one of the following: <ul style="list-style-type: none"> <li>• See <a href="#">Corrective Actions for Recoverable Faults on page 34</a>.</li> <li>• Refer to the <a href="#">Wire Your Controller on page 39</a>.</li> </ul>
0xF006	Recoverable	The user program is incompatible with the Micro800 controller's firmware revision.	Perform one of the following: <ul style="list-style-type: none"> <li>• See <a href="#">Corrective Actions for Recoverable Faults on page 34</a>.</li> <li>• Contact your local Rockwell Automation technical support representative.</li> </ul>

**List of Error Codes for Micro800 controllers**

<b>Error Code</b>	<b>Fault Type</b>	<b>Description</b>	<b>Recommended Action</b>
0xF010	Recoverable	The user program contains a function/function block that is not supported by the Micro800 controller.	Perform one of the following: <ul style="list-style-type: none"> <li>• See <a href="#">Corrective Actions for Recoverable Faults on page 34</a>.</li> <li>• Contact your local Rockwell Automation technical support representative.</li> </ul>
0xF014	Recoverable	A memory module memory error occurred.	<ul style="list-style-type: none"> <li>• See <a href="#">Corrective Actions for Recoverable Faults on page 34</a>.</li> <li>• Reprogram the memory module. If the error persists, replace the memory module.</li> </ul>
0xF015	Non-recoverable	An unexpected software error occurred.	Perform one of the following: <ul style="list-style-type: none"> <li>• See <a href="#">Corrective Actions for Non-recoverable Faults on page 34</a>.</li> <li>• Refer to <a href="#">Wiring Requirements and Recommendation on page 39</a>.</li> </ul>
0xF016	Non-recoverable	An unexpected hardware error occurred.	Perform one of the following: <ul style="list-style-type: none"> <li>• See <a href="#">Corrective Actions for Non-recoverable Faults on page 34</a>.</li> <li>• Refer to <a href="#">Wiring Requirements and Recommendation on page 39</a>.</li> </ul>
0xF017	Non-recoverable	An unexpected software error occurred due to unexpected hardware interrupt. If the system variable <code>_SYSVA_USER_DATA_LOST</code> is set, the controller is able to recover the user program but the user data is cleared. If not, the Micro800 controller program is cleared.	Perform one of the following: <ul style="list-style-type: none"> <li>• See <a href="#">Corrective Actions for Non-recoverable Faults on page 34</a>.</li> <li>• Refer to <a href="#">Wiring Requirements and Recommendation on page 39</a>.</li> </ul>
0xF018	Non-recoverable	An unexpected software error occurred due to SPI communication failure. If the system variable <code>_SYSVA_USER_DATA_LOST</code> is set, the controller is able to recover the user program but the user data is cleared. If not, the Micro800 controller program is cleared.	Perform one of the following: <ul style="list-style-type: none"> <li>• See <a href="#">Corrective Actions for Non-recoverable Faults on page 34</a>.</li> <li>• Refer to <a href="#">Wiring Requirements and Recommendation on page 39</a>.</li> </ul>
0xF019	Non-recoverable	An unexpected software error occurred due to memory or other controller resource issue.	See <a href="#">Corrective Actions for Non-recoverable Faults on page 34</a> .
0xF01A	Recoverable	The controller was unexpectedly reset during Run Mode Change (RMC) due to a noisy environment or an internal hardware failure. If the system variable <code>_SYSVA_USER_DATA_LOST</code> is set, the controller is able to recover the user program but the user data is cleared. If not, the Micro800 controller program is cleared.	See <a href="#">Corrective Actions for Recoverable Faults on page 34</a> .
0xF020	Recoverable	The base hardware faulted or is incompatible with the Micro800 controller's firmware revision.	See <a href="#">Corrective Actions for Recoverable Faults on page 34</a> .
0xF021	Recoverable	The I/O configuration in the user program is invalid or does not exist in the Micro800 controller.	See <a href="#">Corrective Actions for Recoverable Faults on page 34</a> .
0xF022	Recoverable	The user program in the memory module is incompatible with the Micro800 controller's firmware revision.	Perform one of the following: <ul style="list-style-type: none"> <li>• See <a href="#">Corrective Actions for Recoverable Faults on page 34</a>.</li> <li>• Replace the memory module.</li> </ul>

**List of Error Codes for Micro800 controllers**

<b>Error Code</b>	<b>Fault Type</b>	<b>Description</b>	<b>Recommended Action</b>
0xF023	Non-recoverable	The controller program has been cleared. This happened because: <ul style="list-style-type: none"> <li>• a power down occurred during program download or transfer from the memory module.</li> <li>• the Flash Integrity Test failed (Micro810 only).</li> </ul>	Perform one of the following: <ul style="list-style-type: none"> <li>• See <a href="#">Corrective Actions for Non-recoverable Faults on page 34</a>.</li> <li>• Download or transfer the program.</li> </ul>
0xF030 0xF031 0xF032 0xF033	Recoverable	Power down information in persistent memory may not be written properly due to a noisy environment or an internal hardware failure. If the system variable <code>_SYSVA_USER_DATA_LOST</code> is set, the controller is able to recover the user program but the user data is cleared. If not, the Micro800 controller program is cleared.	See <a href="#">Corrective Actions for Recoverable Faults on page 34</a> .
0xF050	Recoverable	The embedded I/O configuration in the user program is invalid.	See <a href="#">Corrective Actions for Recoverable Faults on page 34</a> .
0xF100	Recoverable	There is general configuration error detected in the motion configuration downloaded from the Connected Components Workbench software, such as number of axis, or motion execution interval being configured out of range.	Perform the following: <ul style="list-style-type: none"> <li>• See <a href="#">Corrective Actions for Recoverable Faults on page 34</a>.</li> <li>• Correct the axes configuration in the user program.</li> </ul>
0xF110	Recoverable	There is motion resource missing, such as <code>Motion_DIAG</code> variable not defined.	Perform the following: <ul style="list-style-type: none"> <li>• See <a href="#">Corrective Actions for Recoverable Faults on page 34</a>.</li> <li>• Correct the axes configuration in the user program.</li> </ul>
0xF12z <sup>(1)</sup>	Recoverable	Motion configuration for axis z cannot be supported by this controller model, or the axis configuration has some resource conflict with some other motion axis, which has been configured earlier.	Perform the following: <ul style="list-style-type: none"> <li>• See <a href="#">Corrective Actions for Recoverable Faults on page 34</a>.</li> <li>• Remove all axes and re-configure motion with the guidance from the User Manual.</li> </ul>
0xF15z <sup>(1)</sup>	Recoverable	There is a motion engine logic error (firmware logic issue or memory crash) for one axis detected during motion engine cyclic operation. One possible reason can be motion engine data/memory crash.	See <a href="#">Corrective Actions for Recoverable Faults on page 34</a> .
0xF210	Recoverable	The expansion I/O terminator is missing.	Perform the following: <ol style="list-style-type: none"> <li>1. Power off the controller.</li> <li>2. Attach the expansion I/O terminator on the last expansion I/O module on the system.</li> <li>3. Power on the controller.</li> <li>4. See <a href="#">Corrective Actions for Recoverable Faults on page 34</a>.</li> </ol>
0xF230	Recoverable	The maximum number of expansion I/O modules has been exceeded.	Perform the following: <ol style="list-style-type: none"> <li>1. Power off the controller.</li> <li>2. Check that the number of expansion I/O modules is not more than four.</li> <li>3. Power on the controller.</li> <li>4. See <a href="#">Corrective Actions for Recoverable Faults on page 34</a>.</li> </ol>
0xF250	Recoverable	There is a non-recoverable error and the expansion I/O module(s) could not be detected.	See <a href="#">Corrective Actions for Recoverable Faults on page 34</a> .
0xF26z <sup>(2)</sup>	Recoverable	An expansion I/O master fault is detected on the system.	See <a href="#">Corrective Actions for Recoverable Faults on page 34</a> .

## List of Error Codes for Micro800 controllers

Error Code	Fault Type	Description	Recommended Action
0xF27z <sup>(2)</sup>	Recoverable	A non-recoverable communication fault has occurred on the expansion I/O module.	Perform one of the following: <ul style="list-style-type: none"> <li>See <a href="#">Corrective Actions for Recoverable Faults on page 34</a>.</li> <li>Replace the slot number z module.</li> </ul>
0xF28z <sup>(2)</sup>	Recoverable	Expansion I/O baudrate error.	Perform one of the following: <ul style="list-style-type: none"> <li>See <a href="#">Corrective Actions for Recoverable Faults on page 34</a>.</li> <li>Replace the slot number z module.</li> </ul>
0xF29z <sup>(2)</sup>	Recoverable	A module fault is detected on your expansion I/O module.	Perform one of the following: <ul style="list-style-type: none"> <li>See <a href="#">Corrective Actions for Recoverable Faults on page 34</a>.</li> <li>Replace the slot number z module.</li> </ul>
0xF2Az <sup>(2)</sup>	Recoverable	Expansion I/O power failure	Perform one of the following: <ul style="list-style-type: none"> <li>See <a href="#">Corrective Actions for Recoverable Faults on page 34</a>.</li> <li>Replace the slot number z module.</li> </ul>
0xF2Bz <sup>(2)</sup>	Recoverable	Expansion I/O configuration fault.	Perform one of the following: <ul style="list-style-type: none"> <li>See <a href="#">Corrective Actions for Recoverable Faults on page 34</a>.</li> <li>Correct the expansion IO module configuration in the user program to match that of the actual hardware configuration.</li> <li>Check the expansion I/O module operation and condition.</li> <li>Replace the expansion I/O module.</li> </ul>
0xF300	Recoverable	The memory module is present but memory module is empty and restore operation is requested.	Perform the following: <ul style="list-style-type: none"> <li>See <a href="#">Corrective Actions for Recoverable Faults on page 34</a>.</li> <li>Check to make sure there is a valid project in the memory module.</li> <li>Download a user program and use the backup function to the memory module.</li> </ul>
0xF301	Recoverable	The memory module's project is not compatible with the controller.	Perform one of the following: <ul style="list-style-type: none"> <li>See <a href="#">Corrective Actions for Recoverable Faults on page 34</a>.</li> <li>Check to make sure there is a user program with a controller that has the correct controller catalog configured.</li> <li>Download a user program and use the backup function to the memory module.</li> </ul>
0xF302	Recoverable	The password is mismatched between memory module and controller. Only applies to Micro820 controller when Remote LCD performs the restore operation. This fault does not apply to Micro800 controller firmware revision 10 and later.	Perform one of the following: <ul style="list-style-type: none"> <li>See <a href="#">Corrective Actions for Recoverable Faults on page 34</a>.</li> <li>Check to make sure that the user program in the memory module has the correct password.</li> <li>Download a user program with a password and use the backup function to the memory module.</li> <li>Use Connected Components Workbench to enter the correct password into the controller and perform the restore operation again.</li> </ul>
0xF303	Recoverable	The memory module is not present and restore operation is requested.	Check to make sure the memory module is present.

**List of Error Codes for Micro800 controllers**

<b>Error Code</b>	<b>Fault Type</b>	<b>Description</b>	<b>Recommended Action</b>
0xF0Az <sup>(3)</sup>	Recoverable	The plug-in I/O module experienced an error during operation.	Perform the following: <ul style="list-style-type: none"> <li>• Check the condition and operation of the plug-in I/O module.</li> <li>• See <a href="#">Corrective Actions for Recoverable Faults on page 34</a>.</li> </ul>
0xF0Bz <sup>(3)</sup>	Recoverable	The plug-in I/O module configuration does not match the actual I/O configuration detected.	Perform one of the following: <ul style="list-style-type: none"> <li>• See <a href="#">Corrective Actions for Recoverable Faults on page 34</a>.</li> <li>• Correct the plug-in I/O module configuration in the user program to match that of the actual hardware configuration.</li> <li>• Check the condition and operation of the plug-in I/O module.</li> <li>• Replace the plug-in I/O module.</li> </ul>
0xF0Dz <sup>(3)</sup>	Recoverable	When power was applied to the plug-in I/O module or the plug-in I/O module was removed, a hardware error occurred.	Perform the following: <ol style="list-style-type: none"> <li>1. See <a href="#">Corrective Actions for Recoverable Faults on page 34</a>.</li> <li>2. Correct the plug-in I/O module configuration in the user program.</li> <li>3. Build and download the program using Connected Components Workbench.</li> <li>4. Put the Micro800 controller into Run mode.</li> </ol>
0xF0Ez <sup>(3)</sup>	Recoverable	The plug-in I/O module configuration does not match the actual I/O configuration detected.	Perform the following: <ol style="list-style-type: none"> <li>1. See <a href="#">Corrective Actions for Recoverable Faults on page 34</a>.</li> <li>2. Correct the plug-in I/O module configuration in the user program.</li> <li>3. Build and download the program using Connected Components Workbench.</li> <li>4. Put the Micro800 controller into Run mode.</li> </ol>
0xF830	Recoverable	An error occurred in the EII configuration.	Perform the following: <ul style="list-style-type: none"> <li>• See <a href="#">Corrective Actions for Recoverable Faults on page 34</a>.</li> <li>• Review and change the EII configuration in the Micro800 controller properties.</li> </ul>
0xF840	Recoverable	An error occurred in the HSC configuration.	Perform the following: <ul style="list-style-type: none"> <li>• See <a href="#">Corrective Actions for Recoverable Faults on page 34</a>.</li> <li>• Review and change the EII configuration in the Micro800 controller properties.</li> </ul>
0xF850	Recoverable	An error occurred in the STI configuration.	Perform the following: <ul style="list-style-type: none"> <li>• See <a href="#">Corrective Actions for Recoverable Faults on page 34</a>.</li> <li>• Review and change the EII configuration in the Micro800 controller properties.</li> </ul>
0xF860	Recoverable	A data overflow occurred. A data overflow error is generated when the ladder, structured text or function block diagram execution encounters a divide-by-zero.	Perform the following: <ol style="list-style-type: none"> <li>1. See <a href="#">Corrective Actions for Recoverable Faults on page 34</a>.</li> <li>2. Correct the program to ensure that there is no data overflow.</li> <li>3. Build and download the program using Connected Components Workbench.</li> <li>4. Put the Micro800 controller into Run mode.</li> </ol>
0xF870	Recoverable	An index address was out of data space.	Perform the following: <ol style="list-style-type: none"> <li>1. See <a href="#">Corrective Actions for Recoverable Faults on page 34</a>.</li> <li>2. Correct the program to ensure that there is no index used to access an array element beyond the array boundaries.</li> <li>3. Build and download the program using Connected Components Workbench.</li> <li>4. Put the Micro800 controller into Run mode.</li> </ol>

**List of Error Codes for Micro800 controllers**

<b>Error Code</b>	<b>Fault Type</b>	<b>Description</b>	<b>Recommended Action</b>
0xF0878	Recoverable	An index used to access a bit is beyond the boundaries of the data type it is used on.	<p>Perform the following:</p> <ol style="list-style-type: none"> <li>1. See <a href="#">Corrective Actions for Recoverable Faults on page 34</a>.</li> <li>2. Correct the program to ensure that there is no index used to access a bit beyond the boundaries of the data type.</li> <li>3. Build and download the program using Connected Components Workbench.</li> <li>4. Put the Micro800 controller into Run mode.</li> </ol>
0xF880	Recoverable	A data conversion error occurred.	<p>Perform the following:</p> <ol style="list-style-type: none"> <li>1. See <a href="#">Corrective Actions for Recoverable Faults on page 34</a>.</li> <li>2. Correct the program to ensure that there is no data conversion error.</li> <li>3. Build and download the program using Connected Components Workbench.</li> <li>4. Put the Micro800 controller into Run mode.</li> </ol>
0xF888	Recoverable	The call stack of the controller cannot support the sequence of calls to function blocks in the current project. Too many blocks are within another block.	<p>Perform the following:</p> <ul style="list-style-type: none"> <li>• See <a href="#">Corrective Actions for Recoverable Faults on page 34</a>.</li> <li>• Change the project to reduce the quantity of blocks being called within a block.</li> </ul>
0xF898	Recoverable	An error occurred in the user interrupt configuration for the plug-in I/O module.	<p>Perform the following:</p> <ul style="list-style-type: none"> <li>• See <a href="#">Corrective Actions for Recoverable Faults on page 34</a>.</li> <li>• Correct the user interrupt configuration for plug-in I/O module in the user program to match that of the actual hardware configuration.</li> </ul>
0xF8A0	Recoverable	The TOW parameters are invalid.	<p>Perform the following:</p> <ol style="list-style-type: none"> <li>1. See <a href="#">Corrective Actions for Recoverable Faults on page 34</a>.</li> <li>2. Correct the program to ensure that there are no invalid parameters.</li> <li>3. Build and download the program using Connected Components Workbench.</li> <li>4. Put the Micro800 controller into Run mode.</li> </ol>
0xF8A1	Recoverable	The DOY parameters are invalid.	<p>Perform the following:</p> <ol style="list-style-type: none"> <li>1. See <a href="#">Corrective Actions for Recoverable Faults on page 34</a>.</li> <li>2. Correct the program to ensure that there are no invalid parameters.</li> <li>3. Build and download the program using Connected Components Workbench.</li> <li>4. Put the Micro800 controller into Run mode.</li> </ol>



**List of Error Codes for Micro800 controllers**

<b>Error Code</b>	<b>Fault Type</b>	<b>Description</b>	<b>Recommended Action</b>
0xFFzz <sup>(4)</sup>	Recoverable	A user-created fault from Connected Components Workbench has occurred.	See <a href="#">Corrective Actions for Recoverable Faults on page 34</a> .
0xD00F	Recoverable	A particular hardware type (for example, embedded I/O) was selected in the user program configuration, but did not match the actual hardware base.	See <a href="#">Corrective Actions for Recoverable Faults on page 34</a> .
0xD011	Recoverable	The program scan time exceeded the watchdog timeout value.	<p>Perform the following:</p> <ul style="list-style-type: none"> <li>• See <a href="#">Corrective Actions for Recoverable Faults on page 34</a>.</li> <li>• Determine if the program is caught in a loop and correct the problem.</li> </ul> <p>Fault may occur if your Structured Text program contains a For loop with the upper limit set to the maximum value of the variable. For example, the variable is a USINT and the limit is set to 255, or the variable is a UINT and the limit is set to 65535.</p> <p>To correct the fault, perform the following:</p> <ol style="list-style-type: none"> <li>1. Correct the program to ensure that the upper limit is not reached. One method is to use a data type with a larger maximum value.</li> <li>2. Build and download the program using Connected Components Workbench.</li> <li>3. Put the Micro800 controller into Run mode.</li> </ol> <p>If your program is designed to have a scan time of longer than three seconds, in the user program, increase the watchdog timeout value that is set in the system variable <code>_SYSVA_TCYWDG</code> and then build and download the program using Connected Components Workbench.</p>

- (1) z indicates the logic axis ID. (0...3)
- (2) z indicates the slot number of the expansion I/O. If z=0, then the slot number cannot be identified.
- (3) z is the slot number of the plug-in module. If z = 0, then the slot number cannot be identified.
- (4) zz indicates the last byte of the program number. Only program numbers up to 0xFF can be displayed. For program numbers 01x00 to 0xFFFF, only the last byte is displayed.)

## Corrective Action for Recoverable and Non-recoverable Faults

### *Corrective Actions for Recoverable Faults*

Perform the following:

1. Optionally save the fault log from Connected Components Workbench software.
2. Clear the recoverable fault using Connected Components Workbench software.
3. If problem persists, contact technical support with the fault log.

### *Corrective Actions for Non-recoverable Faults*

Perform the following:

1. Power cycle your Micro800 controller.
2. Controller will go to recoverable fault. Optionally save the fault log from Connected Components Workbench software.
3. Clear the recoverable fault using Connected Components Workbench software.
4. If program is lost, build and download your program using Connected Components Workbench software.
5. If problem persists, contact technical support with the fault log.

# Controller Fault Recovery Model

Use the following fault recovery model to help you diagnose software and hardware problems in the micro controller. The model provides common questions you might ask to help troubleshoot your system. Refer to the recommended pages within the model for further help.

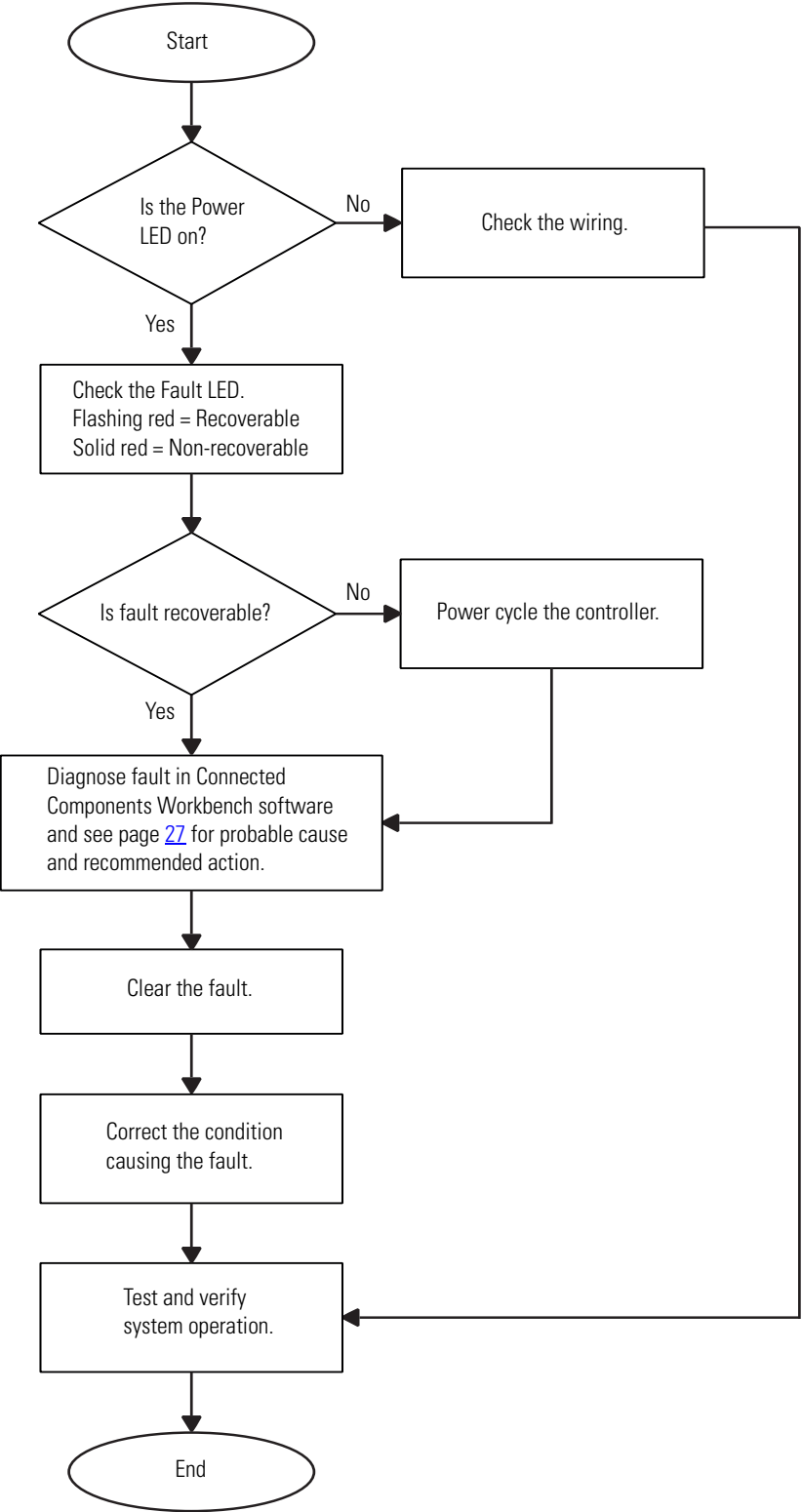

## Calling Rockwell Automation for Assistance

If you need to contact Rockwell Automation or local distributor for assistance, it is helpful to obtain the following (prior to calling):

- controller type, series letter, revision letter, and firmware (FRN) number of the controller
- controller indicator status

## Program Execution in Micro800

### Configure and Program Your Micro810 Controller

The Micro810 controller can be configured by either:

- using Smart Relay function blocks using the 2080-LCD display (and without the use of Connected Components Workbench programming software), or
- programmed as a full feature microcontroller using Connected Components Workbench.

You cannot use both the Smart Relay function blocks and also download a Connected Components Workbench program. You must choose one of the two methods. Smart Relay function blocks are targeted to simple applications such as a timer relay for lighting. Downloading a program using Connected Components Workbench overwrites the Smart Relay function blocks. Conversely, configuring the Smart Relay function blocks overwrites any Connected Components Workbench program.

For instructions on how to use Smart Relay functionality, see [Use the Micro810 Smart Relay Functionality on page 70](#). For quickstart instructions on how to use the Connected Components Workbench, see the following publications:

- Micro800 and Connected Components Workbench Application Guide, publication [2080-QR001](#)
- Micro800 and Connected Components Workbench Getting Started Guide, publication [2080-QR002](#)

For program execution on Connected Components Workbench, see the next sections.

### Overview of Program Execution

A Micro800 cycle or scan consists of reading inputs, executing programs in sequential order, updating outputs and performing communications housekeeping.

Program names must begin with a letter or underscore, followed by up to 127 letters, digits or single underscores. Use programming languages such as ladder logic, function block diagrams and structured text.

Up to 256 programs may be included in a project, depending on available controller memory. By default, the programs are cyclic (executed once per cycle or scan). As each new program is added to a project, it is assigned the next consecutive order number. When you start up the Project Organizer in Connected Components Workbench, it displays the program icons based on this

order. You can view and modify an order number for a program from the program's properties. However, the Project Organizer does not show the new order until the next time the project is opened.

The Micro800 supports jumps within a program. Call a subroutine of code within a program by encapsulating that code as a User Defined Function (UDF) or User Defined Function Block (UDFB). Although a UDFB can be executed within another UDFB, a maximum nesting depth of five is supported. A compilation error occurs if this is exceeded.

Alternatively, you can assign a program to an available interrupt and have it executed only when the interrupt is triggered. The User Fault Routine is the only interrupt available in Micro810 controllers. A program assigned to the User Fault Routine runs once just prior to the controller going into Fault mode.

The Global System Variables associated with cycles/scans are:

- `__SYSVA_CYCLECNT` - Cycle counter
- `__SYSVA_TCYCURRENT` - Current cycle time
- `__SYSVA_TCYMAXIMUM` - Maximum cycle time since last start.

## Execution Rules

This section illustrates the execution of a program. The execution follows eight main steps within a loop. The loop duration is a cycle time for a program.

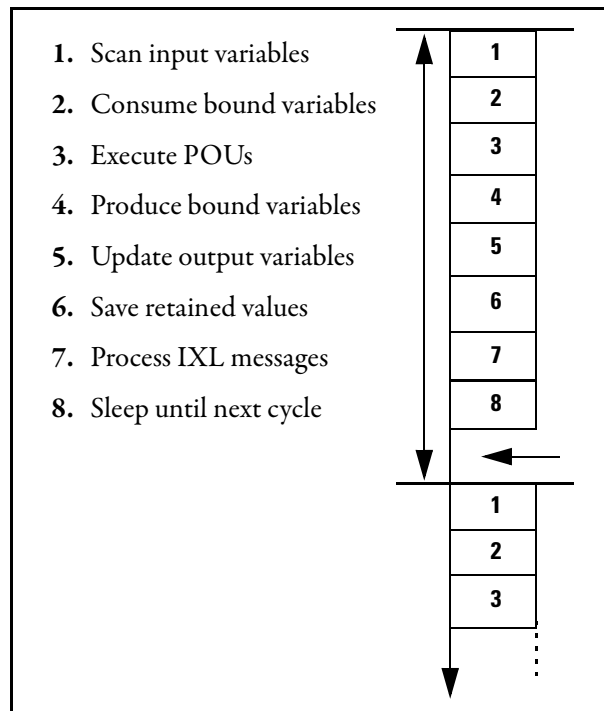

In a case where bindings are defined, variables consumed by a resource are updated after the inputs are scanned and the variables produced for other resources are sent before updating inputs.

When a cycle time is specified, a resource waits until this time has elapsed before starting the execution of a new cycle. The POU's execution time varies depending on the number of active steps in SFC programs and instructions such as jumps, IFs, and returns. When a cycle exceeds the specified time, the loop continues to execute the cycle but sets an overrun flag. In such a case, the application no longer runs in real time.

When a cycle time is not specified, a resource performs all steps in the loop then restarts a new cycle without waiting.

## Power Up and First Scan

In Program mode, all analog and digital input variables hold their last state, and the LEDs are always updated. Also all digital output variables hold their last state but the digital outputs are off.

When transitioning from Program mode to Run mode, all digital output variables are cleared.

Two system variables are also available from revision 2 and later.

### System Variables for Scan and Powerup on Firmware Release 2 and later

Variable	Type	Description
_SYSVA_FIRST_SCAN	BOOL	First scan bit. Can be used to initialize or reset variables immediately after every transition from Program to Run mode. <b>Note:</b> True only on first scan. After that, go to run.
_SYSVA_POWER_UP_BIT	BOOL	Powerup bit. Can be used to initialize or reset variables immediately after download from Connected Components Workbench or immediately after being loaded from memory backup module (for example, 2080-MEMBAK-RTC, 2080-LCD). <b>Note:</b> True only on the first scan after a powerup, or running a new ladder for the first time.

## Periodic Execution of Programs

It is not recommended that the system variable `__SYSVA_TCYCYCTIME` be used to periodically execute all programs as this also causes the communication to execute at this rate.



**WARNING:** Communication timeouts may occur if programmed cycle time is set too slow (for example, 200 ms) to maintain communications.

### System Time Variable for Programmed Cycle Time

Variable	Type	Description
<code>__SYSVA_TCYCYCTIME</code>	TIME	Programmed cycle time. <b>Note:</b> Programmed cycle time only accepts values in multiples of 10 ms. If the entered value is not a multiple of 10, it will be rounded up to the next multiple of 10.

## Memory Allocation

Available memory on Micro810 controllers is shown in the table below.

### Memory Allocation for Micro810 Controllers

Attribute	Micro810 12-point
Program steps <sup>(1)</sup>	2 K
Data bytes	2 KB

(1) Estimated Program and Data size are “typical” – program steps and variables are created dynamically.  
1 Program Step = 12 data bytes.

These specifications for instruction and data size are typical numbers. When a project is created for Micro800, memory is dynamically allocated as either program or data memory at build time. This means that program size can exceed the published specifications if data size is sacrificed and vice versa. This flexibility allows maximum usage of execution memory. In addition to the user defined variables, data memory also includes any constants and temporary variables generated by the compiler at build time.

The Micro800 controllers also have project memory, which gets downloaded by the Connected Components Workbench software. This embedded file is a copy of the entire downloaded project, including comments and symbolic variable names. If too many comments or variable names are contained in the project, a compile error may occur referring to “embedded file size too large.” If this occurs, reduce the number of comments and variables in the project.



## Guidelines and Limitations

Here are some guidelines and limitations to consider when programming a Micro800 controller using Connected Components Workbench software:

- Each program/Program Organizational Unit (POU) can use up to 64 Kb of internal address space. It is recommended that you split large programs into smaller programs to improve code readability, simplify debugging and maintenance tasks.
- A User Defined Function Block (UDFB) can be executed within another UDFB, with a limit of 5 nested UDFBs. Avoid creating UDFBs with references to other UDFBs, as executing these UDFBs too many times may result in a compile error.

### Example of 5 nested UDFBs

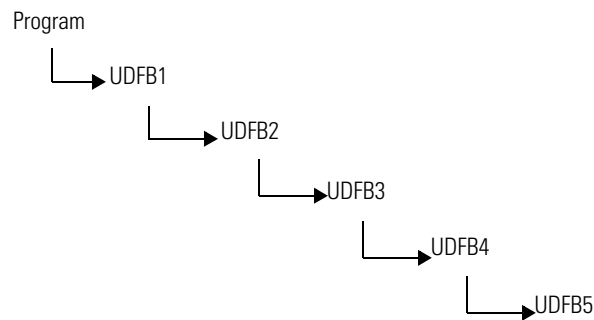

- Structured Text (ST) is much more efficient and easier to use than Ladder Logic, when used for equations. If you are used to using the RSLogix500 CPT Compute instruction, ST combined with UDFB is a great alternative.

As an example, for an Astronomical Clock Calculation, Structured Text uses 40% less Instructions.

Display\_Output LD:

Memory Usage (Code) : 3148 steps  
Memory Usage (Data) : 3456 bytes

Display\_Output ST:

Memory Usage (Code) : 1824 steps  
Memory Usage (Data) : 3456 bytes

- You may encounter an issue with downloading and compiling a program over a certain size. One workaround is to use arrays, especially if there are many variables.

**Notes:**

## Controller Security

Micro800 security generally has two components:

- **Exclusive Access** which prevents simultaneous configuration of the controller by two users
- **Controller Password Protection** which secures the Intellectual Property contained within the controller and prevents unauthorized access

Additionally, for Micro810 controllers, the 2080-LCD has a password feature to secure the LCD display.

---

**IMPORTANT** On Micro810 controllers, the controller password feature enforces password protection on software connections to the controller (that is, any connection through the Connected Components Workbench software). The password that is activated on the 2080-LCD restricts access to the LCD alone and to system functions that are accessible via the LCD. These are two distinct passwords.

To learn more about activating passwords on the LCD, see [Configure LCD Password on page 61](#).

---

### Exclusive Access

Exclusive access is enforced on the Micro800 controller regardless of whether the controller is password-protected or not. This means that only one Connected Components Workbench session is authorized at one time and only an authorized client has exclusive access to the controller application. This ensures that only one software session has exclusive access to the Micro800 application-specific configuration.

Exclusive access is enforced on Micro800 firmware revision 1 and 2. When a Connected Components Workbench user connects to a Micro800 controller, the controller is given exclusive access to that controller.

### Password Protection

By setting a password on the controller, a user effectively restricts access to the programming software connection of the controller to software sessions that can supply the correct password. Essentially, Connected Components Workbench operation such as upload and download are prevented if the controller is secured with a password and the correct password is not provided.

Micro800 controllers with firmware revision 2 are shipped with no password but a password can be set through the Connected Components Workbench software (revision 2 or later).

The controller password is also backed up to the memory backup module (that is, 2080-MEMBAK-RTC for Micro830 and Micro850, 2080-LCD for Micro810; and microSD card for Micro820 controllers). If the password in the backup module is different from the memory backup module, then restore operation will fail.

**TIP** For instructions on how to set, change, and clear controller passwords, see [Configure Controller Password on page 47](#).

## Compatibility

The Controller Password feature is supported on:

- Connected Components Workbench **revision 2** and later
- Micro800 controllers with **revision 2** firmware

For users with earlier versions of the software and/or hardware, refer to the compatibility scenarios below.

### *Connected Components Workbench revision 1 with Micro800 controller firmware revision 2*

Connection to a Micro800 controller with firmware revision 2 using an earlier version of the Connected Components Workbench software (revision 1) is possible and connections will be successful. However, the software will not be able to determine whether the controller is locked or not.

If the controller is not locked, access to the user application will be allowed, provided the controller is not busy with another session. If the controller is locked, access to the user application will fail. Users will need to upgrade to revision 2 of the Connected Components Workbench software.

### *Connected Components Workbench revision 2 with Micro800 controller firmware revision 1*

Connected Components Workbench revision 2 is capable of "discovering" and connecting to Micro800 controllers with firmware revision earlier than revision 2 (that is, not supporting the Controller Password feature). However, the Controller Password feature will not be available to these controllers. The user will not be able see interfaces associated with the Controller Password feature in the Connected Components Workbench session.

Users are advised to upgrade the firmware. See [Flash Update the Micro800 Firmware on page 98](#) for instructions.

## Work with a Locked Controller

The following workflows are supported on compatible Micro800 controllers (firmware revision 2) and Connected Components Workbench software revision 2.

---

## Upload from a Password-Protected Controller

1. Launch the Connected Components Workbench software.
2. In the Project Organizer, expand Catalog by clicking the + sign.
3. Select the target controller.
4. Select Upload.
5. When requested, provide the controller password.

## Debug a Password-Protected Controller

To debug a locked controller, you have to connect to the controller through the Connected Components Workbench software and provide the password before you can proceed to debug.

1. Launch the Connected Components Workbench software.
2. In the Project Organizer, expand Catalog by clicking the + sign.
3. Select the catalog number of your controller.
4. When requested, provide the controller password.
5. Build and save your project.
6. Debug.

## Download to a Password-Protected Controller

1. Launch the Connected Components Workbench software.
2. Click Connect.
3. Select the target controller.
4. When requested, provide the controller password.
5. Build and save the project, if needed.
6. Click Download.
7. Click Disconnect.

---

**IMPORTANT** If communication is lost during the download, repeat the download and verify that the controller is password protected.

---

## Transfer Controller Program and Lock Receiving Controller

In this scenario, the user needs to transfer user application from controller1 (locked) to another Micro800 controller with the same catalog number. The

transfer of the user application is done through the Connected Components Workbench software by uploading from controller1, then changing the target controller in the Micro800 project, and then downloading to controller2. Finally, controller2 will be locked.

1. In the Project Organizer, click the Discover icon.  
The Browse Connections dialog appears.
2. Select target controller1.
3. When requested, enter the controller password for controller1.
4. Build and save the project.
5. Click Disconnect.
6. Power down controller1.
7. Swap controller1 hardware with controller2 hardware.
8. Power up controller2.
9. Click Connect.
10. Select target controller2.
11. Click Download.
12. Lock controller2. See [Configure Controller Password on page 47](#).

## Back Up and Restore a Password-Protected Controller

In this workflow, user application will be backed up from a Micro800 controller that is locked to a memory plug-in device.

1. In the Project Organizer, click the Discover icon.  
The Browse Connections dialog appears.
2. Select the target controller.
3. When requested, enter the controller password.
4. Back up controller contents to the memory module.  
The project in the memory module is now password locked.
5. Remove the memory module from controller1 and insert into controller2.
6. Restore the project from the memory module to controller2.
7. This operation succeeds only if the controller has no password, or the controller's password matches the project's password.

If the controller has no password, the project will be restored to the controller, then the controller will be set with the same password as the project.

---

## Configure Controller Password

To set, change, and clear controller password, see the quickstart instructions [Configure Controller Password on page 47](#).

## Recover from a Lost Password

If the controller is secured with a password and the password has been lost, then it is impossible to access the controller using the Connected Components Workbench software.

To recover, the controller must be set to Program Mode using the keyswitch for Micro830 and Micro850 controllers, the 2080-LCD for Micro810 controllers, or the 2080-REMLCD for Micro820 controllers. Then, ControlFlash can be used to update the controller firmware, which also clears the controller memory. In Connected Components Workbench software version 10 or later, the Reset option must be selected for the controller memory to be cleared during the firmware update. If the Upgrade or Downgrade option is selected, the password is retained.



**ATTENTION:** The project in the controller will be lost but a new project can be downloaded.

---

**Notes:**



## Specifications

### Micro810 Controllers

#### General – 2080-LC10-12AWA, 2080-LC10-12QWB, 2080-LC1012DWD, 2080-LC10-12QBB

Attribute	2080-LC10-12AWA	2080-LC10-12QWB	2080-LC1012DWD	2080-LC10-12QBB
Number of I/O	8 Input (4 digital, 4 analog/digital, configurable) 4 Output			
Dimensions HxWxD	91 x 75 x 59 mm (3.58 x 2.95 x 2.32 in.)			
Supply voltage range	85...263V	20.4...26.4V DC	10.8V...13.2V DC	11.4V...26.4V DC
Supply frequency range (AC supply)	47...63 Hz	–		
Voltage range	100...240V AC, 50/60 Hz	24V DC Class 2	12V DC Class 2	12/24V DC Class 2
Power consumption	5V A	3 W		
I/O rating	Input: 120...240V AC  Output: Relay 00 & 01: 8 A @ 240V AC, B300, R300, General Use Relay 02 & 03: 4 A @ 240V AC, C300, R150, General Use	Input: 24V DC, 8 mA	Input: 12V DC, 8 mA	Input: 24V DC, 8 mA Output: 24V DC 1A, 25 °C, 24V DC 0.5A 55°C
Shipping weight, approx.	0.203 kg (0.448 lb)			
Wire size	0.32... 2.1 mm <sup>2</sup> (22...14 AWG) solid copper wire or 0.32... 1.3 mm <sup>2</sup> (22...16 AWG) stranded copper wire rated @ 90 °C (194 °F) insulation max.			
Wiring category <sup>(1)</sup>	2 – on signal ports 2 – on power ports			
Wiring torque	1.085 Nm (8 lb-in.)			
Wire type	use Copper Conductors only			
Fuse, type	Rated 250V 3.15 A-RADIAL			
Enclosure type rating	Meets IP20			
North American temp code	T5			
Insulation stripping length	7 mm (0.28 in.)			
Isolation voltage	250V (continuous), Reinforced Insulation Type, I/O to Aux and Network, Inputs to Outputs. Type tested for 60 s 3250V DC, I/O to Aux and Network, Inputs to Outputs	250V (continuous), Reinforced Insulation Type, I/O to Aux and Network, Inputs to Outputs Type tested for 60 s @ 720V DC, Inputs to Aux and Network, 3250V DC Outputs to Aux and Network, Inputs to Outputs		50V (continuous), Reinforced Insulation Type, I/O to Aux and Network, Inputs to Outputs Type tested for 60 s @ 720V DC, I/O to Aux and Network, Inputs to Outputs
AC input filter setting	16 ms for all embedded inputs (Through the Connected Components Workbench software, go to the Embedded I/O configuration window to re-configure the filter setting for each input group)			

(1) Use this Conductor Category information for planning conductor routing. Refer to Industrial Automation Wiring and Grounding Guidelines, publication [1770-4.1](#).

**Non-isolated AC Inputs (2080-LC10-12AWA)**

Attribute	Value
On-state voltage, nom	120/240V AC
On-state voltage, min	79V AC
On-state voltage, max	265V AC
Off-state voltage, max	40V AC
Off-state current, max	0.095 mA
Operating frequency, nom	50/60 Hz
Input impedance	423.7 kΩ
Operating frequency	47...63 Hz

**Isolated AC Inputs (2080-LC10-12QWB, 2080-LC10-12QBB, 2080-LC10-DWD)  
(Inputs 0...3)**

Attribute	Value
On-state voltage, nom	12/24V AC @ 50/60 Hz
Off-state voltage, min	4V AC @ 50/60Hz
Operating frequency, nom	50/60 Hz

**DC Inputs (2080-LC10-12QWB, 2080-LC10-12QBB, 2080-LC10-12DWD)**

Attribute	Non-isolated, shared with analog inputs (Inputs 4...7)	Isolated (Inputs 0...3)
Voltage category	24V DC sink/source	
On-state voltage, nom	12/24V DC	
On-state voltage, min	9.8V DC	
On-state voltage, max	28.8V DC	
Off-state voltage, max	5V DC	
Off-state current, max	0.5 mA	1.5 mA
On-state current, min	0.75 mA @ 10.8V DC 1.0 mA @ 15V DC	1.8 mA @ 10.8V DC 2.7 mA @ 15 V DC
On-state current, nom	2.1 mA @ 24V DC	6 mA @ 24V DC
On-state current, max	2.7 mA @ 28.8V DC	7.5 mA @ 28.8V DC
Nominal impedance	14.1 kΩ (non-isolated)	3.74 kΩ (isolated)
IEC input compatibility	Type 1	Type 3

**Analog Inputs (2080-LC10-12QWB, 2080-LC10-12QBB, 2080-LC10-12DWD)  
(Inputs 4...7)**

Attribute	Value
Input type	DC voltage
Input voltage range	0...10V DC
Input voltage, max	26.4V DC
Value of LSB	10 mV
Input resolution	10-bit
Input data count range	0...1023
Smoothing	None, smoothing
Overall accuracy	5% of full-scale (2% with calibration) (25...55 °C) (77...131 °F)
Noise rejection	50/60 Hz
Common mode rejection	40 dB, DC to 60 Hz with smoothing filter
Nominal impedance	14.1 k $\Omega$ (non-isolated)

**DC Output (2080-LC10-12QBB)**

Attribute	Value
User supply voltage, min	10V DC
User supply voltage, max	26.4V DC
On-state voltage drop	1V @ max load current 2.5V @ max surge current
Current ratings (each point)	0.5 A @ 55 °C, max 1.0 A @ 30 °C, max 1.0 mA, min
Surge current, peak	4.0 A
Surge current, max duration	10 ms
Controller current	3 A
Turn-on- time, max	0.1 ms
Turn-off time, max	1.0 ms

**Relay Outputs (2080-LC10-12AWA, 2080-LC10-12QWB, 2080-LC10-12DWD)**

Attribute	Value
Output rating	Relay 00 & 01: 8 A @ 240V AC, 5 A @ 24V DC, B300, R300 Relay 02 & 03: 4 A @ 240V AC, 2 A @ 24V DC, C300, R150
Voltage, min	5V AC/DC
Voltage, max	250V AC, 30V DC @ rated current. See details on page <a href="#">52</a> .
Turn on time	15 ms
Turn off time	5 ms

**Relay Output Life**

Attribute	Value
Mechanical	10,000,000 cycles
Electrical with rated load	50,000 cycles

**Embedded RTC**

Attribute	Value
Resolution READ_RTC()	1 sec
Accuracy	± 12 sec/month @ 25 °C ± 160 sec/month @ 0...55 °C
Power off	Supercap — 5 days @ 40 °C or lower Supercap life — 5 years @ 40 °C, 14.5 years @ 25 °C

**Micro810 High Current Relay Chart**

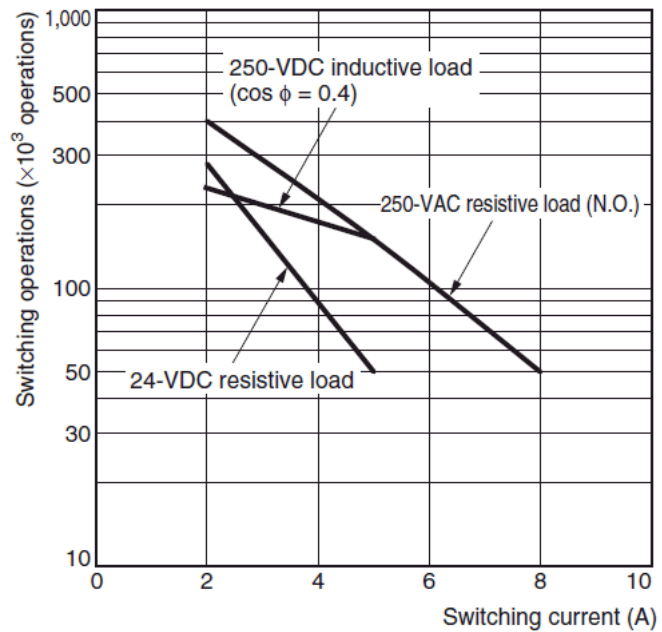

Maximum Volts	IEC 947	Amperes		Amperes Continuous	Volt-Amperes	
		Make	Break		Make	Break
120V AC	AC-15	30 A	3 A	8 A	3600V A	360V A
240V AC	AC-15	15.0 A	1.5 A	8 A	3600V A	360V A
125V DC	DC-13	0.22 A		1.0 A	28V A	
250V DC	DC-13	0.11 A		1.0 A	28V A	
24V DC	DC-13	1.2 A		5.0 A	28V A	

**Micro810 Low Current Relay Chart**

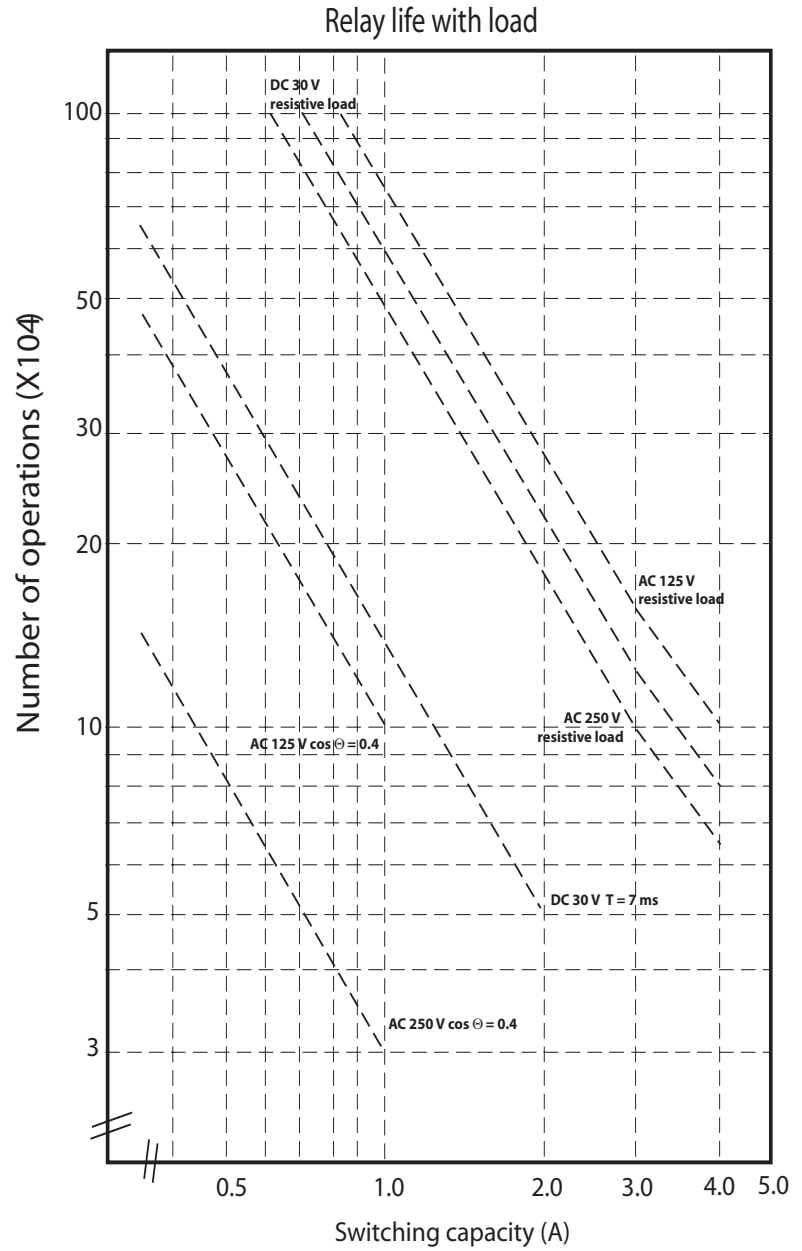

Maximum Volts	IEC 947	Amperes		Amperes Continuous	Volt-Amperes	
		Make	Break		Make	Break
120V AC	AC-15	15 A	1.5 A	4 A	1800V A	180V A
240V AC	AC-15	7.5 A	0.75 A	4 A	1800V A	180V A
125V DC	DC-13	0.22 A		1.0 A	28V A	
24V DC	DC-13	1.2 A		4.0 A	28V A	

**Environmental**

Attribute	Value
Temperature, operating	IEC 60068-2-1 (Test Ad, Operating Cold), IEC 60068-2-2 (Test Bd, Operating Dry Heat), IEC 60068-2-14 (Test Nb, Operating Thermal Shock): 0...55 °C (32...131 °F)
Temperature, surrounding air, max	55 °C (131 °F)
Temperature, storage	IEC 60068-2-1 (Test Ab, Unpackaged Non-operating Cold), IEC 60068-2-2 (Test Bb, Unpackaged Non-operating Dry Heat), IEC 60068-2-14 (Test Na, Unpackaged Non-operating Thermal Shock): -40...85 °C (-40...185 °F)
Relative humidity	IEC 60068-2-30 (Test Db, Unpackaged Damp Heat): 5...95% non-condensing
Vibration	IEC 60068-2-6 (Test Fc, Operating): 2 g @ 10...500 Hz
Shock, operating	IEC 60068-2-27 (Test Ea, Unpackaged Shock): 30 g
Shock, nonoperating	IEC 60068-2-27 (Test Ea, Unpackaged Shock): 30 g (DIN Rail Mounted) 30 g (Panel Mounted)
Emissions	CISPR 11 Group 1, Class A
ESD immunity	IEC 61000-4-2: 4 kV contact discharges 8 kV air discharges
Radiated RF immunity	IEC 61000-4-3: 10V/m with 1 kHz sine-wave 80% AM from 80...2000 MHz 10V/m with 200 Hz 50% Pulse 100% AM @ 900 MHz 10V/m with 200 Hz 50% Pulse 100% AM @ 1890 MHz 3V/m with 1 kHz sine-wave 80% AM from 2000...2700 MHz
EFT/B immunity	IEC 61000-4-4: ±2 kV @ 5 kHz on power ports ±2 kV @ 5 kHz on signal ports
Surge transient immunity	IEC 61000-4-5: ±1 kV line-line(DM) and ±2 kV line-earth(CM) on power ports ±1 kV line-line(DM) and ±2 kV line-earth(CM) on signal ports ±2 kV line-earth(CM) on shielded ports
Conducted RF immunity	IEC 61000-4-6: 10V rms with 1 kHz sine-wave 80% AM from 150 kHz...80 MHz
Voltage variation	IEC 61000-4-11: 60% dip for 5 and 50 periods on AC supply ports 30% dip for 0.5 period at 0° and 180° on AC supply ports 100% dip for 0.5 period at 0° and 180° on AC supply ports ±10% fluctuations for 15 min on AC supply ports > 95% interruptions for 250 periods on AC supply ports

**Certifications**

<b>Certification (when product is marked)<sup>(1)</sup></b>	<b>Value</b>
c-UL-us	UL Listed Industrial Control Equipment, certified for US and Canada. See UL File E322657.  UL Listed for Class I, Division 2 Group A,B,C,D Hazardous Locations, certified for U.S. and Canada. See UL File E334470.
CE	European Union 2004/108/EC EMC Directive, compliant with: EN 61000-6-2; Industrial Immunity EN 61000-6-4; Industrial Emissions EN 61131-2; Programmable Controllers (Clause 8, Zone A & B) EN 61131-2; Programmable Controllers (Clause 11)
C-Tick	Australian Radiocommunications Act, compliant with: AS/NZS CISPR 11; Industrial Emissions

(1) See the Product Certification link at <http://www.rockwellautomation.com/products/certification/> for Declaration of Conformity, Certificates, and other certification details.

## Micro800 Programmable Controller External AC Power Supply

### General

Attribute	Value
Dimensions, HxWxD	90 x 45 x 80 mm (3.55 x 1.78 x 3.15 in.)
Shipping weight	0.34 kg (0.75 lb)
Supply voltage range <sup>(1)</sup>	100V...120V AC, 1 A 200...240V AC, 0.5 A
Supply frequency	47...63 Hz
Supply power	24V DC, 1.6 A
Inrush current, max	24A @ 132V for 10 ms 40A @ 263V for 10 ms
Power consumption (Output power)	38.4 W @ 100V AC, 38.4 W @ 240V AC
Power dissipation (Input power)	45.1 W @ 100V AC, 44.0 W @ 240V AC
Isolation voltage	250V (continuous), Primary to Secondary: Reinforced Insulation Type Type tested for 60s @ 2300V AC primary to secondary and 1480V AC primary to earth ground.
Output ratings	24V DC, 1.6A, 38.4 W max.
Enclosure type rating	Meets IP20
Wire size	0.32... 2.1 mm <sup>2</sup> (22...14 AWG) solid copper wire or 0.32... 1.3 mm <sup>2</sup> (22...16 AWG) stranded copper wire rated @ 90 °C (194 °F) insulation max
Terminal screw torque	0.5...0.6 Nm (4.4...5.3 lb-in.) (using a Phillips-head or 2.5 mm (0.10in.) flat-blade screwdriver)
Wiring category <sup>(2)</sup>	2 – on power ports
Insulation stripping length	7 mm (0.28 in.)
North American temp code	T4A

(1) Any fluctuation in voltage source must be within 85V...264V. Do not connect the adapter to a power source that has fluctuations outside of this range.

(2) Use this Conductor Category information for planning conductor routing. Refer to Industrial Automation Wiring and Grounding Guidelines, publication [1770-4.1](#).



## About Accessories

### Accessories

This chapter highlights the accessories you can use with the Micro810 controller.

### External AC Power Supply

Use this optional power supply (2080-PS120-240VAC) in applications with smaller systems when a 24V DC power supply is not readily available.

#### Wire the Module

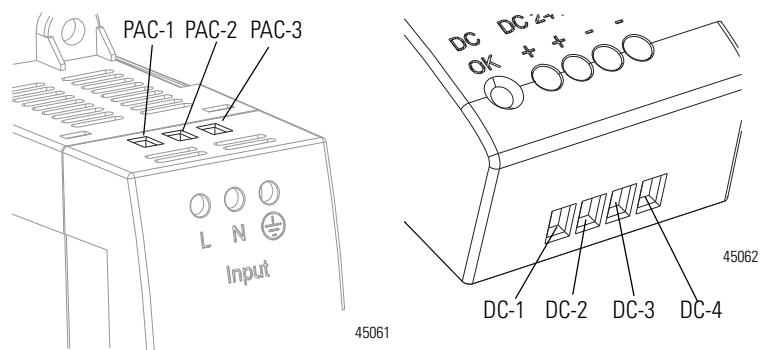

AC Input Connectors			DC Output Connectors (DC 24V/ 1.6 A)		
PAC-1	AC hot	100...240V AC	DC-1	+	
PAC-2	AC neutral	100...240V AC	DC-2	+	
PAC-3	Safety ground		DC-3	-	
			DC-4	-	

## 1.5" LCD Display and Keypad Module

This module (2080-LCD) also functions as a backup memory module for the Micro810 controller.

This module offers an affordable and simple method of viewing status and configuring the Micro810 Controller. With this LCD module, you can also modify core Smart Relay function blocks.

The LCD Display instructions can be used to display custom messages as well as to read keystrokes.

This module may be inserted or removed when power is applied to the controller, but only in non-hazardous locations. Be sure that power is removed or the area is nonhazardous before proceeding.

### *Insert the LCD Module*

1. Remove blank cover plate.
2. Push in the LCD module until it latches on the top and bottom.

### *Remove the LCD Module*

1. Squeeze the top and bottom latches, then pull out the top first, then the bottom.



**ATTENTION:** Make sure to fully insert or remove the LCD module, otherwise the controller may fault.

---

### Access the Main Menu

Press the ESC and OK buttons at the same time to access the Main Menu screen.

Use the arrow keys to move the cursor up or down to the item you want to select.

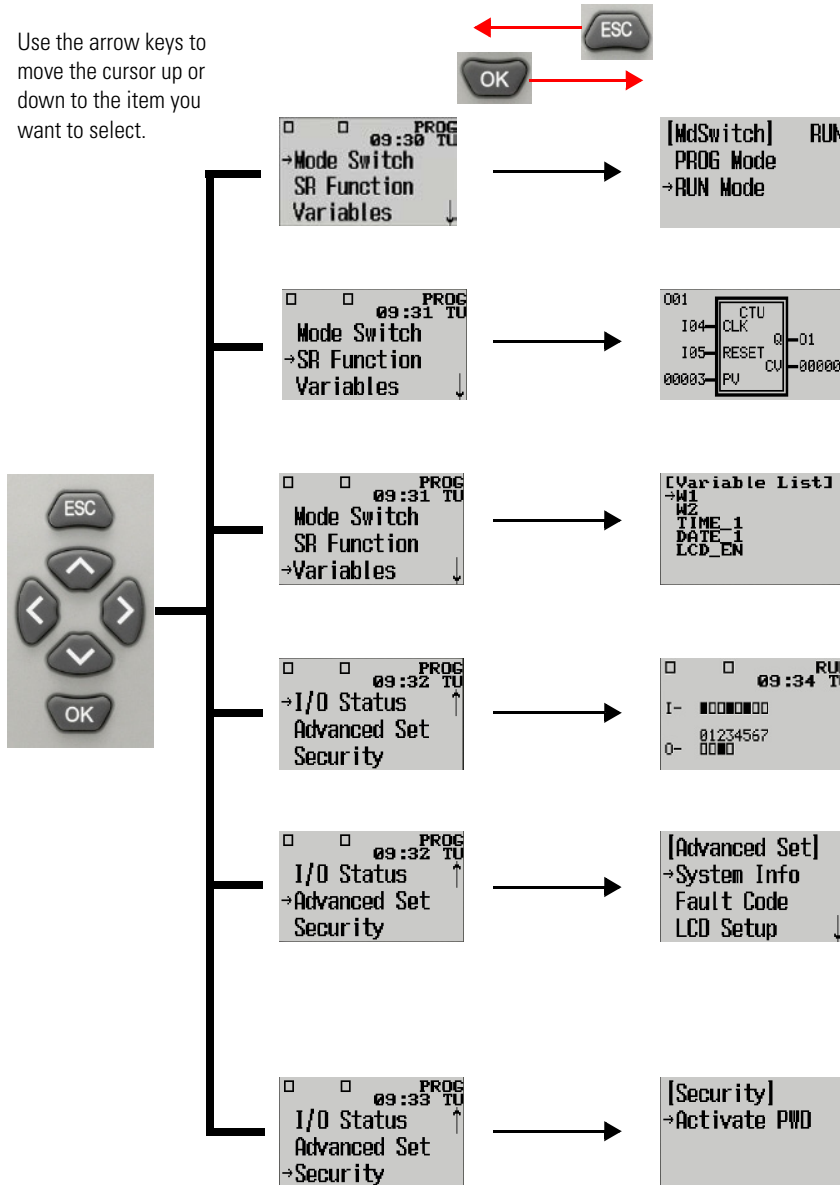

#### Mode Switch

Set the controller to Program Mode or Run mode from this screen.

#### SR Function

Use the LEFT and RIGHT arrow keys to select the parameters. Use the UP and DOWN arrow keys to set the value for a parameter.

#### Variable

Monitor or set values for program-defined variables. This feature is implemented in firmware revision 7.xxx onwards.

#### I/O Status

Monitor the I/O status from this screen.

#### Advance Set

View:

System Info	Input Filter
Fault Code	AI Calibration
LCD Setup	PwrUp Behavior
Clock Set	Memory Module
Language	

#### Security

Set or Reset the Password.

## USB Adapter

This module (2080-USBADAPTER) provides the Micro810 controller with a USB port.



Use a standard USB A Male to B Male cable for programming the controller.



45221

## Quickstarts

This appendix covers some common tasks for the Micro810 controller. It includes the following quickstart instructions:

Topic	Page
Configure LCD Password	61
Configure Controller Password	66
Use the Micro810 Smart Relay Functionality	70
Flash Update the Micro800 Firmware	98
Establish Communication Between RSLinx and a Micro810 12-point controller through USB	101
Forcing I/O	103

### Configure LCD Password

The Micro810 function relay settings which are accessible through the LCD can be password protected. The password consists of a value between 00000001 and 99999999.

**TIP** The number combination 00000000 is used to delete the password.

Password protection blocks access to the System menu and thus offers protection against the following:

- modification of function relay parameters
- changing between operating modes Run or Stop.
- settings of the real-time clock
- communication with individual device
- modification of system parameters
  - set new password
  - menu language selection
  - input filter
  - AI Calibration
  - Power Up Behavior
  - Memory Module

## Activate Password

Passwords can be set in the System menu in both Run or Stop operating modes. If, however, a password is already activated, you will not be able to access most of the items from the System menu unless you deactivate the password.

1. Press Esc and OK to call up the System menu.
2. Select the menu item SECURITY.
3. Press the OK button and select Activate PWD.
4. Press the OK button again to access the password entry area.



5. Set the password (from 00000001 to 99999999) using the cursor buttons:
  - left and right arrows move to the 8-digit entry field
  - left and right arrows select digit in password
  - up and down arrows set a value between 0 and 9.
6. Save the new password by pressing OK.
7. Press OK or Esc to exit the password display.
  - The password is now valid but not yet activated.

## Deactivate Password

---

**IMPORTANT** Using the Deactivate Password option only deactivates the password **for the current session**. When the controller is power cycled, the LCD password that has been previously set is still enforced. You will have to deactivate the password again to access most system functions.

---

To be able to unlock the LCD and gain access to most system functions, you need to use the Deactivate Password option.

Deactivating the password grants you access to such functions as Mode Switch, Smart Relay, Security, Advanced Settings such as Clock Setup, Input Filter, AI Calibration, PwrUp Behavior, and Memory Module.

1. Press Esc and OK to call up the System menu.
2. Select the menu item SECURITY.

3. Press the OK button and select Deactivate PWD.  
Deactivate Password option is available only if a password has been previously set.

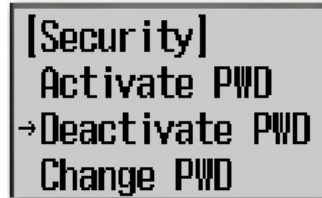

4. Enter the password you have previously set using the arrow buttons.
  - left and right arrows move to the 8-digit entry field
  - left and right arrows select digit in password
  - up and down arrows set a value between 0 and 9.

The following message appears when the deactivation is successful:



5. Press OK.

You are now granted access to such system functions as smart relay, and Advanced Settings.

## Change Password

1. Press Esc and OK to call up the System menu.
2. Select the menu item SECURITY.
3. Press the OK button and select Change PWD.  
Change Password option is available only if a password has been previously set.

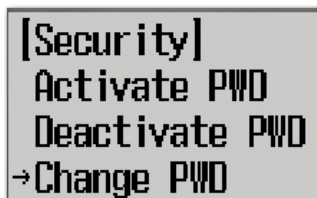

4. Enter the OLD password you have previously set using the arrow buttons.



- left and right arrows move to the 8-digit entry field
  - left and right arrows select digit in password
  - up and down arrows set a value between 0 and 9.
5. Enter the New Password using the arrow buttons.
  6. Press OK.

## Delete Password

**TIP** Deleting the password effectively unlocks the LCD. On the next controller power cycle, a password will not be required to access system functions on the LCD.

You need to set the password as **00000000** to delete the password that has been previously set. To do this, follow the next instructions:

1. Press Esc and OK to call up the System menu.
2. Select the menu item SECURITY.
3. Press the OK button and select Change PWD.  
Change Password option is available only if a password has been previously set.

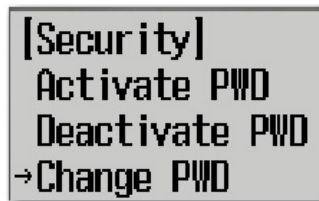

4. Enter the OLD password you have previously set using the arrow buttons.

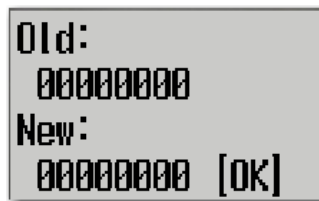

- left and right arrows move to the 8-digit entry field
- left and right arrows select digit in password



- up and down arrows set a value between 0 and 9.
5. Enter the New Password as **0000000** to delete the password.  
Use the arrow buttons as in the previous step.
  6. Press OK.

## Configure Controller Password

Set, change, and clear the password on a target controller through the Connected Components Workbench software.

**IMPORTANT** The following instructions are supported on Connected Components Workbench revision 2 and Micro800 controllers with firmware revision 2. For more information about this feature, see [Controller Security on page 43](#).

### Set Controller Password

In the following instructions, the Connected Components Workbench software is connected to the Micro800 controller.

1. On the Connected Components Workbench software, open the project for the target controller.
2. Click Connect to connect to the target controller.

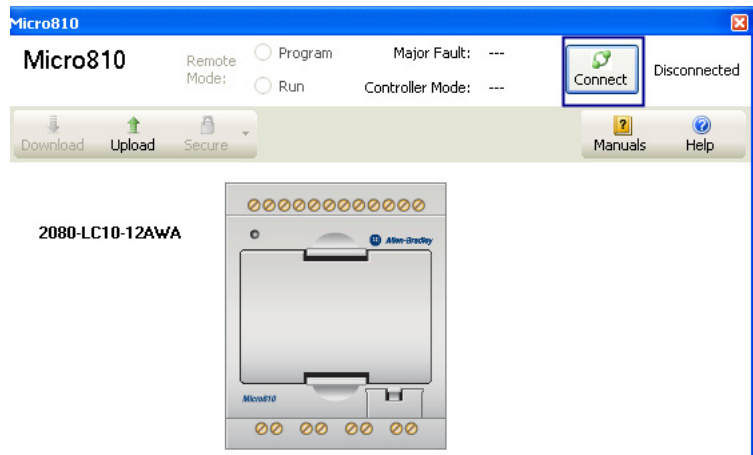

3. On the Device Details toolbar, roll over the Secure button. The tooltip message “Set, Change. or Clear Micro800 Controller Password Protection” is displayed.

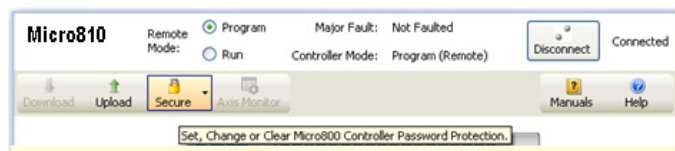

- Click Secure button. Select Set Password.

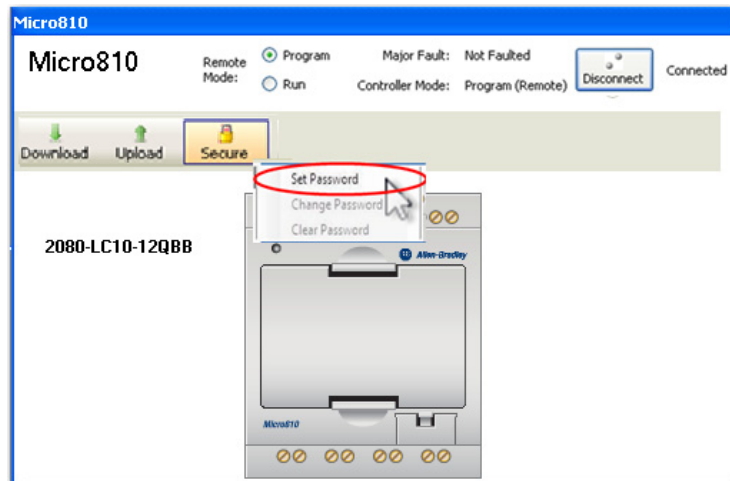

- The Set Controller Password dialog appears. Provide password. Confirm the password by providing it again in the Confirm field.



**TIP** Passwords must have at least eight characters to be valid.

- Click OK.  
The Confirmation dialog box appears to confirm that the password has been set successfully.

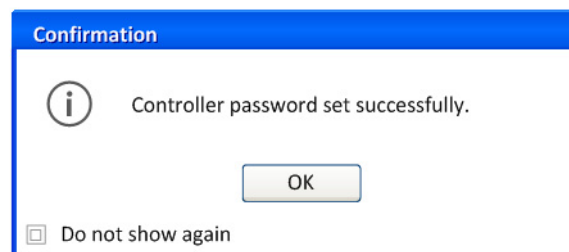

- Click OK.

Once a password is created, any new sessions that try to connect to the controller will have to supply the password to gain exclusive access to the target controller.

## Change Password

With an authorized session, you can change the password on a target controller through the Connected Components Workbench software. The target controller must be in Connected status.

1. On the Device Details toolbar, click Secure button. Select Change Password.

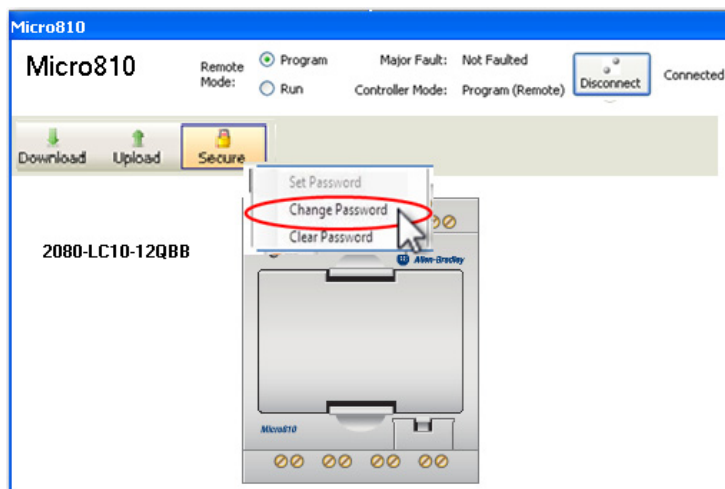

2. The Change Controller Password dialog appears. Enter Old Password, New Password and confirm the new password.



3. Click OK. The Confirmation dialog box appears to confirm that the password has been set successfully.

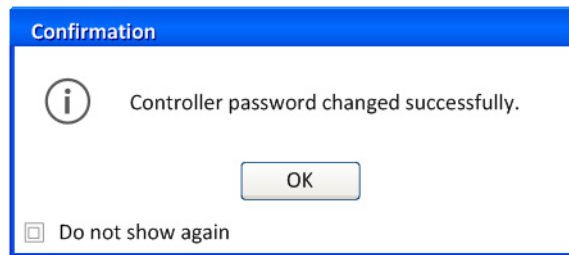

4. Click OK.

The controller will require the new password to grant access to any new session.

## Clear Password

With an authorized session, you can clear the password on a target controller through the Connected Components Workbench software.

1. On the Device Details toolbar, click Secure button. Select Clear Password.

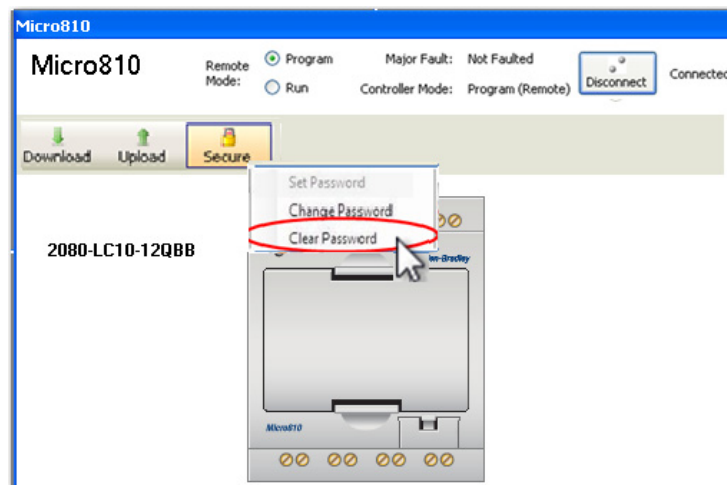

2. The Clear Password dialog appears. Enter Password.
3. Click OK to clear the password.

The controller will require no password on any new session.

## Use the Micro810 Smart Relay Functionality

The Micro810 12-point (8 Inputs and 4 Outputs) controller comes with a built-in smart relay function that can be configured using the optional LCD Display and push buttons to control four relay outputs (O00...O03), without using any software.

Each smart relay block controls one relay output and can be configured using one of the following instructions:

- TON – On-delay Timing
- TOF – Off-delay Timing
- DOY – Turning on an output if the value of real-time clock is in the range of Year Time setting.
- TOW – Turning on an output if the value of real-time clock is in the range of Day Time setting.
- CTU – Count Up
- CTD – Count Down
- TONOF – On-delay timing on a true rung, and then Off-delay timing on the false rung.
- TP – Pulse Timing

### Smart Relay Block Execution Order

The smart relay block that is configured to control output 00 executes first, followed by the smart relay block for output 01, then output 02, with the smart relay block for output 03 as the last to execute.

For example, if TON is configured to control O00, CTU for O01, TOW for O02, and another CTU for O03, the execution sequence for the smart relay instructions is TON (O00) → CTU (O01) → TOW (O02) → CTU (O03).

The default configuration is as follows:

TON for Output 00  
CTU for Output 01  
TOW for Output 02  
DOY for Output 03

## Navigate the LCD Display

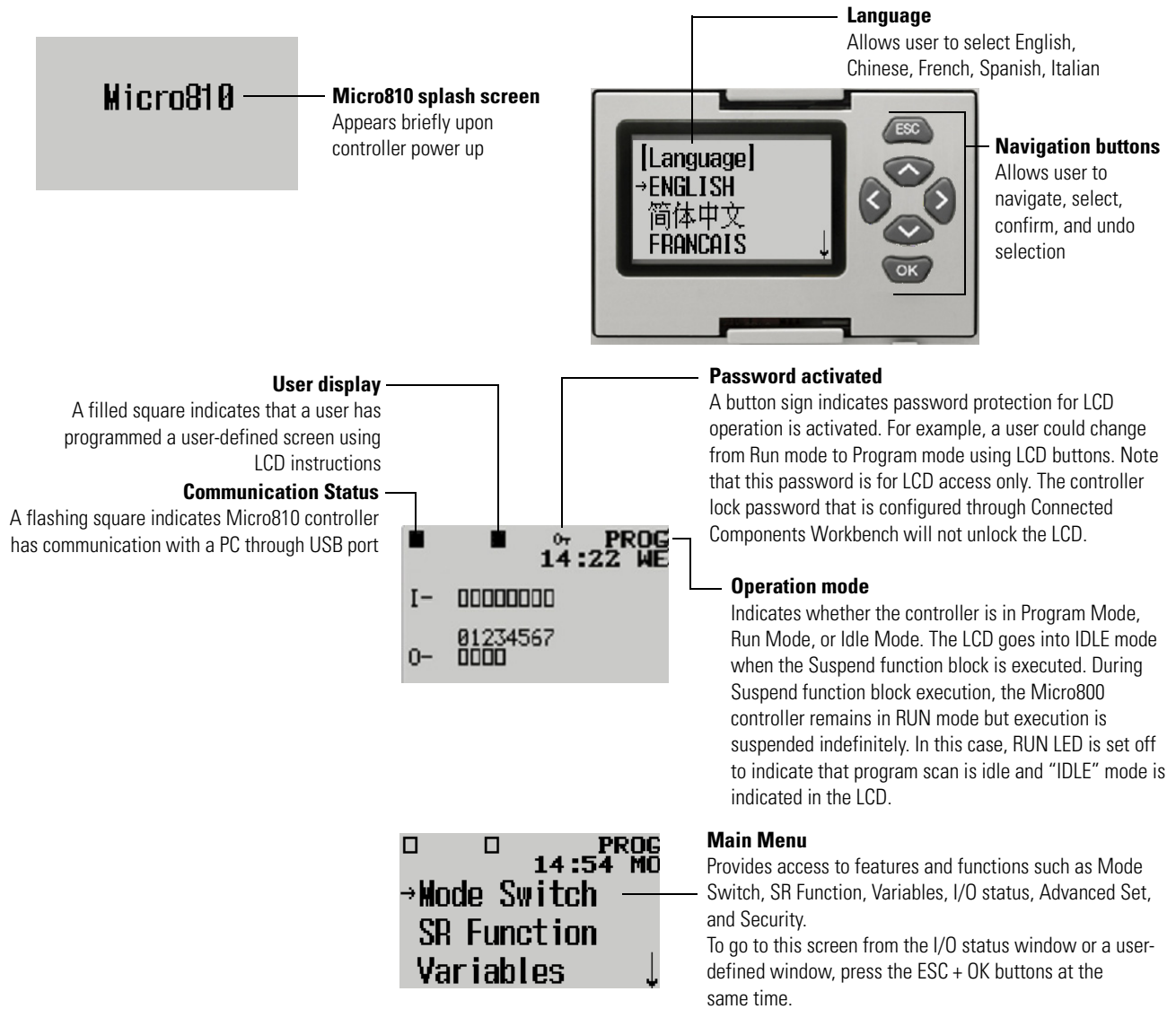

The following sections enable the user to configure and test each of the eight Smart Relay (SR) Functions available to the Micro810 controller.

### Configure Count-Up (CTU)

This quickstart shows you how to configure the Count Up (CTU) function block.

1. Power up the Micro810 controller.  
The Micro810 splash screen briefly appears after power up.

2. The status display shows PROG mode, the day and time, and the I/O status. Press the ESC and OK buttons at the same time to go to the Main Menu.
3. Press the DOWN arrow button to navigate to SR Function. Press the OK button. The function block for controlling Output 0 is displayed.
4. Press the UP arrow button once to navigate to the function block controlling Output 1.

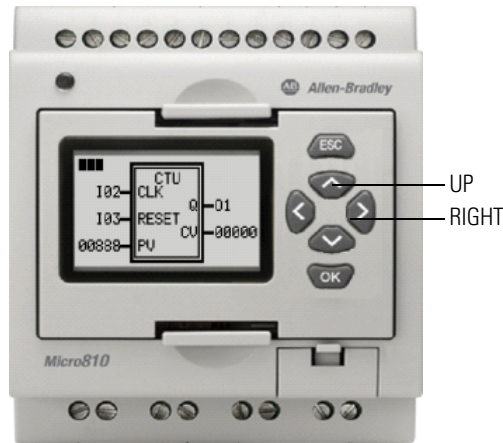

5. Press the RIGHT arrow button once. The instruction parameter field is selected and shows the CTU instruction.
6. Press the RIGHT arrow button once to select the CLK parameter field. This parameter triggers counting.

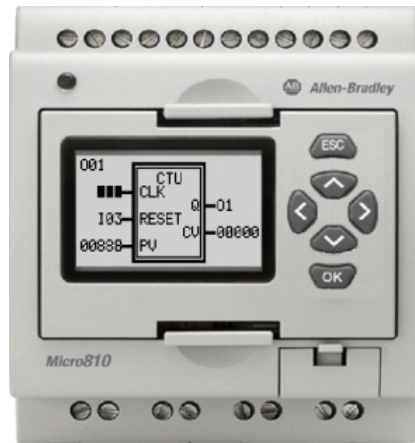

7. Press the RIGHT arrow button once to select the RESET parameter field. This parameter input forces a counter reset.
8. Press the RIGHT arrow button thrice to move to the first non-zero entry in the Preset Value (PV) parameter field.
  - a. Press the UP arrow button twice to turn this digit to zero.
  - b. Press RIGHT arrow button once to position to the next non-zero digit in the PV field. Press the UP arrow button twice to get the digit value of zero.



- c. Press RIGHT arrow button once to go to the last digit. Press the DOWN arrow button five times to set the last digit to 3.

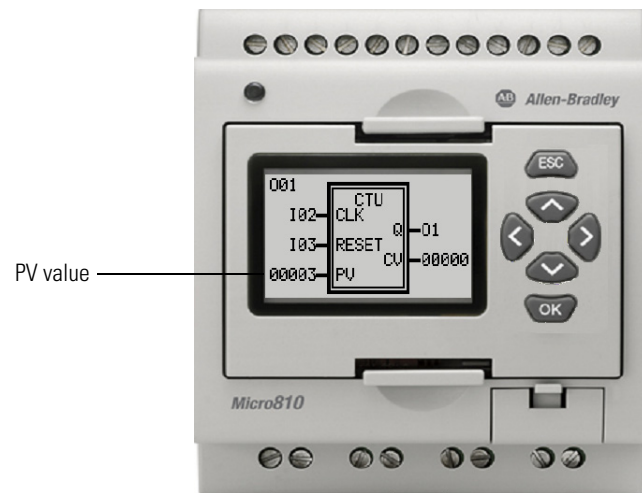

9. Press the RIGHT arrow button once to navigate to the screen selection parameter.

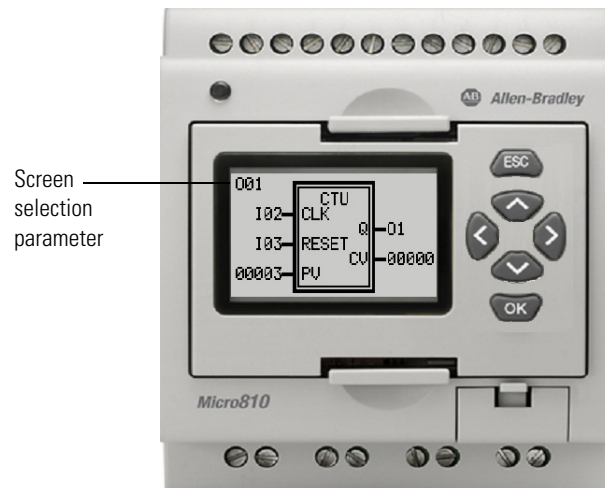

10. Press the OK button to submit the parameter changes. A message prompts you to save the parameter changes. Press the OK button to save the changes.

```
Press OK to save
, ESC to resume
editing.

[ESC]      [OK]
```

## Test the CTU Predefined Function

The CTU instruction increments the counter whenever input CLK makes a transition from low to high. The instruction compares the current value CV with

the preset value PV, and energizes output O1 when CV > PV. To test the operation, we connect a count push button to I02, a reset push button to I03, and a pilot light to output O01.

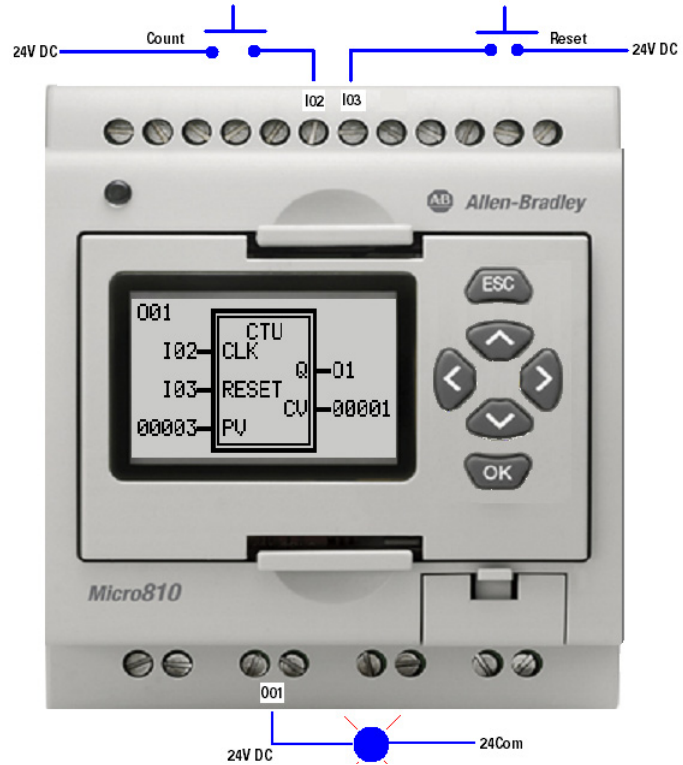

1. Press the ESC button to return to the Main Menu.
2. Press the UP arrow button once to go to Mode Switch. Press the OK button.

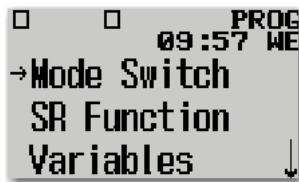

3. Press the DOWN arrow button once to select RUN mode. Press the OK button.

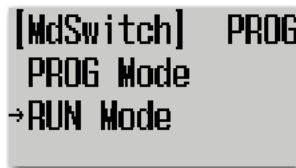

4. Press the OK button to confirm the RUN mode selection.

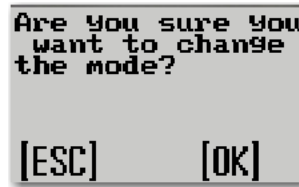

5. The screen indicates that the controller is in RUN mode. Press the ESC button to return to the Main Menu.



6. Press the DOWN arrow button once to navigate to SR Function.
  - a. Press the UP arrow button once to go to CTU function block.

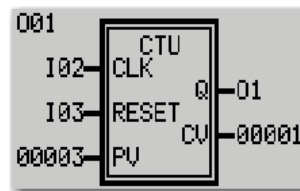

7. Press and release the count push button. The current value CV increments to 00001.

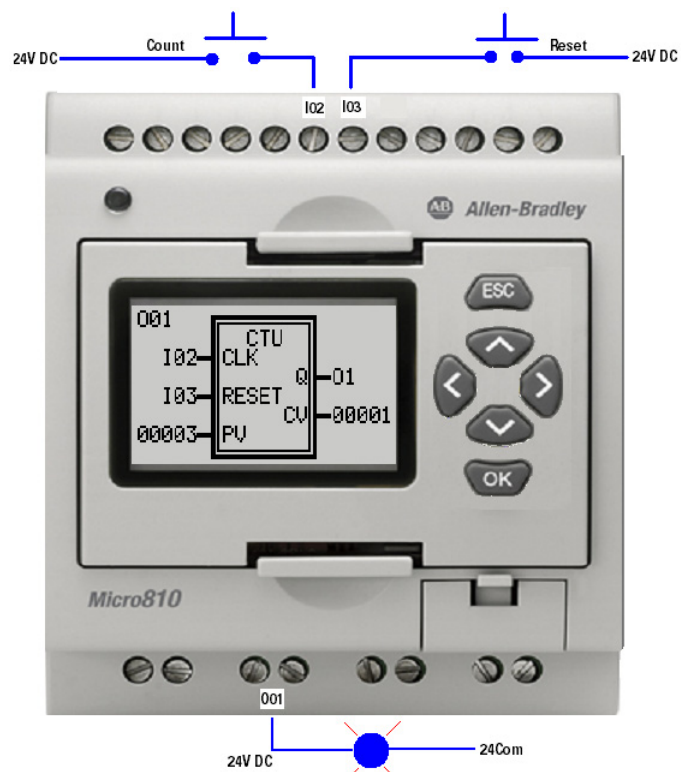

- a. Press and release the count push button. The current value CV increments to 00002.
- b. Press and release the count push button. The current value CV increments to 00003. Since the current value CV = present value PV, the output O1 is energized, and the pilot light turns on.

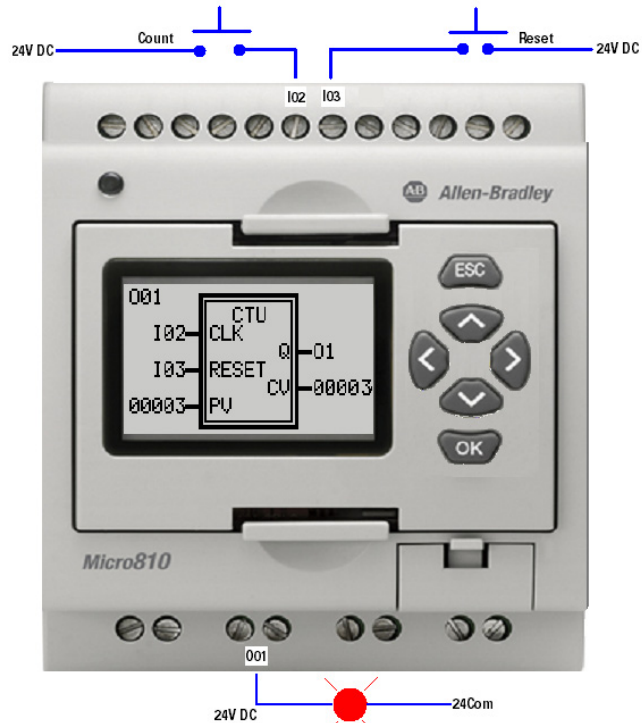

- c. Press and release the Reset push button. The current value CV is reset to zero, and output O1 is de-energized. The pilot light turns off.



## Configure On-delay Timing (TON)

### TON – Sample parameter configuration

Parameter Field	Configuration Value
Q	Q00
IN	I01
Time Resolution	SS:MS
PT	15:000

1. Power up the Micro810 controller.  
The Micro810 splash screen briefly appears after follow up.
2. The status display shows PROG mode, the day and time, and the I/O status. Press the ESC and OK buttons at the same time to navigate to the Main Menu.
3. Press the DOWN arrow button to navigate to SR Function. Press the OK button. The function block for controlling Output 0 is displayed.

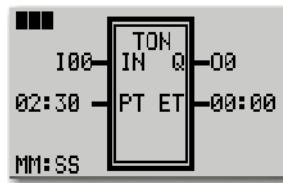

4. Press the RIGHT arrow button once to highlight instruction parameter field TON.
5. Press the RIGHT arrow button once to select the IN parameter value.  
This marks the start for on-delay timer.
6. Press the UP arrow button once to increment IN parameter value from I00 to I01.
7. Press the RIGHT arrow button once to select the Time-Resolution parameter field. This input determines the unit of on-delay timer.

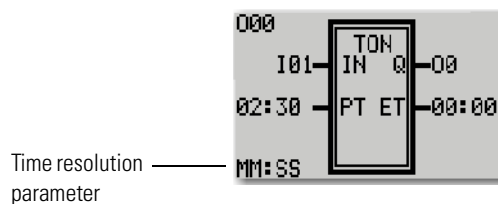

8. Press the DOWN arrow button once to change Time Resolution parameter to SS:MS.

9. Press the RIGHT arrow button once to select the first digit entry in PT parameter field.

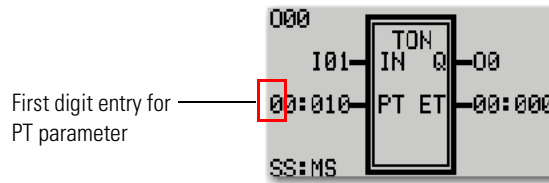

To change the PT parameter value to 15:000, do the following steps:

- a. Press the UP arrow button once to turn the first digit entry to 1.
- b. Press the RIGHT button arrow once to select the second entry in PT parameter field.
- c. Press the UP arrow button five times to increment the digit value to 5.
- d. Press the RIGHT button arrow twice to select the fourth digit entry in PT parameter field.
- e. Press the DOWN arrow button once to turn this digit value to zero.

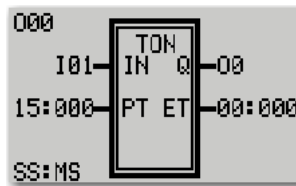

10. Press the OK button to submit the parameter changes.  
A message prompts you to save the parameter changes. Press the OK button to save the changes.

## Test the TON Predefined Function

The TON instruction starts an internal timer up to a given value when input (IN) makes a transition from low to high. The instruction compares the current Elapsed Time (ET) with the programmed time PT, and energize the output when  $ET = PT$ . To test the operation, we connect a push button to I01, and a pilot light to output O00.

1. Press the ESC button to return to the Main Menu.
2. Press the UP arrow button once to select Mode Switch. Press the OK button.
3. Press DOWN arrow button once to select RUN mode. Press the OK button.
4. A message prompts you to confirm RUN mode selection. Press the OK button.
5. Press the ESC button to return to the main menu. The main menu screen indicates that the controller is in RUN mode.

6. Press the DOWN arrow button once and select SR FUNCTION. Press the OK button. The TON function block to control Output 0 becomes available.
7. Press the push button connected to I01. ET starts to elapse.
8. When the current ET equals PT, output O00 is energized, and the pilot light turns on.



## Configure DOY

### DOY – Sample Parameter Configuration

Parameter Field	Configuration Value
Q	Q03
<b>Channel</b>	A
EN	I03
Y/C	0
On	11/08/18 (YY/MM/DD)
Off	11/08/19 (YY/MM/DD)

1. Power up the Micro810 controller.  
The Micro810 splash screen briefly appears after power up.
2. The status display shows PROG mode, the day and time, and the I/O status. Press the ESC and OK buttons at the same time to navigate to the Main Menu.
3. Press the DOWN arrow button once to select SR function. Press the OK button.
4. Press the DOWN arrow button once to navigate to the function block controlling Output 3 (DOY).

5. Press the RIGHT arrow button once to select the DOY instruction parameter field.
6. Press the RIGHT arrow button once. The CHANNEL parameter field is selected and it shows CHANNEL A.

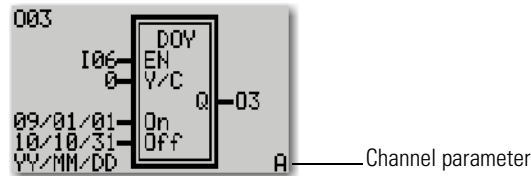

7. Press the RIGHT arrow button to select the EN parameter field. Press the DOWN arrow button four times to change the EN parameter value to I03.

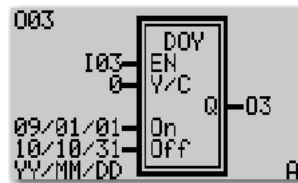

8. Press the RIGHT arrow button twice to select the first digit entry in the ON parameter field.

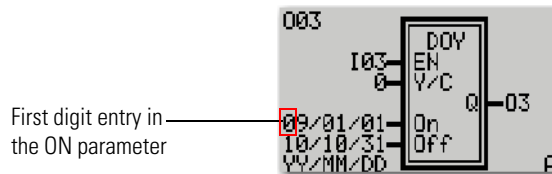

Change the On date settings to 11/08/18 (YY/MM/DD). To do this, follow these steps:

- a. Press the UP arrow button once to get the digit value of 1.
- b. Press the RIGHT arrow button once to select the second entry in the ON parameter field, then press the UP arrow button twice to turn this digit value to 1.
- c. Press the RIGHT arrow button once to select the third and fourth digit entries in the ON parameter field, then press the DOWN arrow button five times to get the digit value 08.
- d. Press the RIGHT arrow button once to select the fourth and fifth digit entries in the ON parameter field, then press the UP arrow button 17 times to get the digit value of 18.

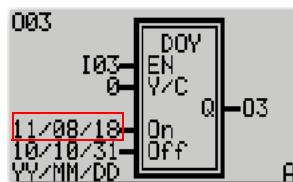



9. Press the RIGHT arrow button once to select the first entry in the OFF parameter field.  
Change the Off date settings to 11/08/19 (YY/MM/DD). To do this, follow these steps:
  - a. Press the RIGHT arrow button once to select the second entry in the OFF parameter field. Then, press the UP arrow button once to get the digit value of 1.
  - b. Press the RIGHT arrow button once to select the third and fourth entries in the OFF parameter field, and press the UP arrow button seven times to get the digit value of 08.
  - c. Press the RIGHT arrow button once to select the fourth and fifth digit entries in OFF parameter field, then press the UP arrow button 18 times to get the digit value of 19.

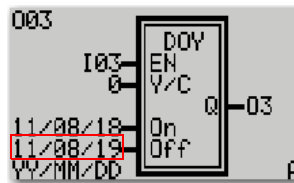

10. Press the OK button to submit the parameter changes.  
A screen confirms your request to save the parameter changes. Press the OK button to save the changes.

## Test the DOY Predefined Function

The DOY instruction turns on the output if the value of the real-time clock is within the Year-Time setting on any of the four channels. To test the operation, we connect a push button to I03, and a pilot light to output O03.

### *Set up the Clock for Testing*

1. Press the ESC button to return to the Main Menu.
2. Press the DOWN arrow button thrice to go to Advanced Set. Press the OK button.



3. Press the DOWN arrow button thrice to go to Clock Setup then press the OK button.  
Press the OK button again on Clock.

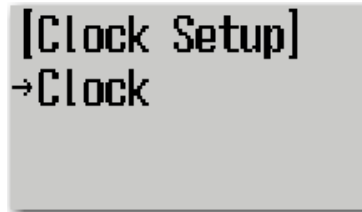

4. Press the RIGHT arrow button to navigate through Year, MM.DD, and HH:MM fields.  
Set the MM.DD field value to the On date established during configuration (11/08/18). Use the UP or DOWN arrow buttons to increase or decrease the digit values on the MM.DD field.
5. Go to the HH:MM field. Change the time setting to 23:59, or a minute before the configured Off date. Use the UP or DOWN arrow buttons to increase or decrease the digit values on the HH:MM field. Press the OK button after editing.



Proceed to the test steps described below.

*Test the DOY Function*

1. Press the ESC button twice to return to the Main Menu.
2. Press the UP arrow button to select Mode Switch. Press the OK button.
3. Press the DOWN arrow button to go to RUN mode, then press the OK button.
  - a. Press the OK button to confirm the switch to RUN mode.
4. Press the ESC button to return to the Main Menu. The screen indicates that the controller is in RUN mode.
5. Press the DOWN arrow button once to select SR FUNCTION. Press the OK button.
6. Press the DOWN arrow button once to get to Output 3 (DOY).

- Press the push button connected to I03. If the value of RTC is in the range of Year-Time setting for CHANNEL A, then the pilot light turns on.



## Configure TOW

### TOW – Sample Parameter Configuration

Parameter Field	Configuration Value
Q	Q02
<b>Channel</b>	A
EN	I03
D/W	0
On	M0-08:30
Off	M0-08:31

- Power up the Micro810 controller.  
The Micro810 splash screen briefly appears after power up.
- The I/O status display shows PROG mode, the day and time, and the I/O status. Press the ESC and OK buttons at the same time to navigate to the Main Menu.
- Press the DOWN arrow button once to select SR Function. Press the OK button. The function block for controlling Output 0 shows up.

4. Press the UP arrow button twice to navigate to the function block for Output 2 (TOW).

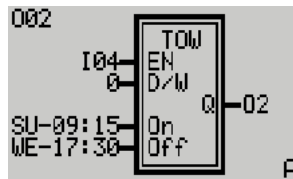

5. Press the RIGHT arrow button once to select the TOW instruction parameter field.
6. Press the RIGHT arrow button once to select CHANNEL parameter field. It shows CHANNEL A.
7. Press the RIGHT arrow button once to select the EN parameter field. Press the DOWN arrow button once to change the EN parameter value to I03.
8. Press the RIGHT arrow button once to select the D/W parameter field.
9. Press the RIGHT arrow button once to select the first entry in the ON parameter field.
  - a. Press the UP arrow button once to change the value to "MO".
  - b. Press the RIGHT arrow button once to select the first and second digit entries in the ON parameter field, and press the DOWN arrow button once to get the digit value of 08.
  - c. Press the RIGHT arrow button once to select the third digit entry in the ON parameter field, and press the UP arrow button twice to get the digit value of 3.
  - d. Press the RIGHT arrow button once to select the fourth digit entry in the ON parameter field, and press the DOWN arrow button 5 times to get the digit value of 0.

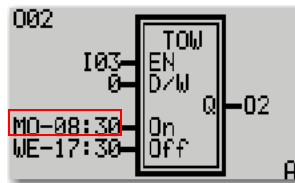

10. Press the RIGHT arrow button once to select the first entry in the OFF parameter field.
  - a. Press the DOWN arrow button twice to change the value to "MO".
  - b. Press the RIGHT arrow button once to select the second and third digit entries in the OFF parameter field, and press the DOWN arrow button nine times to get the digit value of 08.

- c. Press the RIGHT arrow button twice to get to the fifth digit entry in the OFF parameter field, and press the UP arrow button once to get the digit value of 1.

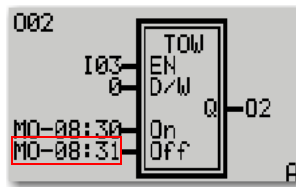

11. Press the OK button to submit the parameter changes.  
A screen confirms your request to save the parameter changes. Press the OK button to save the changes.

## Test the TOW Predefined Function

The TOW instruction turns on output if the value of real-time clock is within the range of the Day-Time setting for any of the four channels. To test the operation, we connect a push button to I03, and a pilot light to output O02.

### *Set up the Clock for Testing*

1. Press the ESC button to return to the Main Menu.
2. Press the DOWN arrow button thrice to go to Advanced Set. Press the OK button.



3. Press the DOWN arrow button thrice to go to Clock Setup then press the OK button.  
Press the OK button again on Clock.



4. Press the RIGHT arrow button to navigate through Year, MM.DD, and HH:MM fields.  
Set the MM.DD field value to a date that falls on a Monday, as set in the Configure example. Use the UP or DOWN arrow buttons to increase or decrease the digit values on the MM.DD field.
5. Go to the HH:MM field. Change the time setting to 08:29, or a minute before the On time set. Use the UP or DOWN arrow buttons to increase or decrease the digit values on the HH:MM field. Press the OK button after editing.

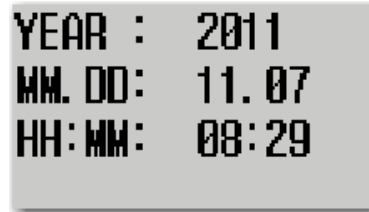

Proceed to the test steps described below.

#### *Test the TOW Function*

1. Press the ESC button twice to return to the Main Menu.
2. Press the UP arrow button to select Mode Switch. Press the OK button.
3. Press the DOWN arrow button once to select RUN mode. Press the OK button.
4. Press the OK button to confirm the RUN mode selection.
5. The screen indicates that the controller is in RUN mode. Press the ESC button to return to the Main Menu.
6. Press the DOWN arrow button once and select SR FUNCTION. Press the OK button.
7. Press the UP arrow button twice for Output 2.

8. Press the push button connected to I03. If the value of RTC is in the range of Day-Time setting for CHANNEL A, the pilot light turns on.

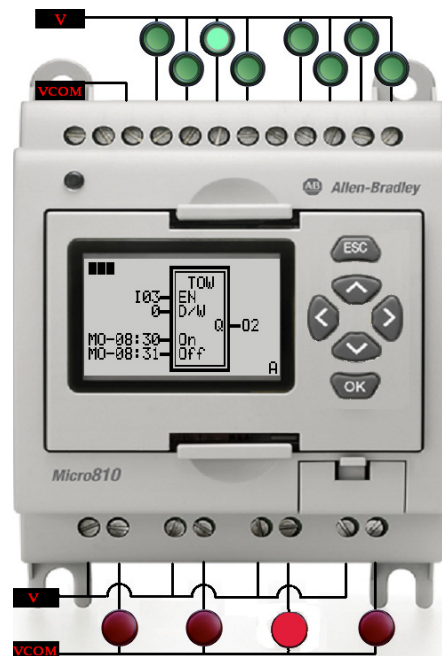

## Configure Countdown (CTD)

### CTD – Sample Parameter Configuration

Parameter field	Configuration value
Q	Q00
CLK	I01
LOAD	I02
PV	00010

1. Power up the Micro810 controller.  
The Micro810 splash screen briefly appears after power up.
2. The status display shows the PROG status, the day and time, and the I/O status. Press the ESC and OK buttons at the same time to navigate to the Main Menu.
3. Press the DOWN arrow button once to select SR Function. Press the OK button. The function block for controlling Output 0 is displayed.
4. Press the RIGHT arrow button once to select the TON instruction parameter field.
5. Press the UP arrow button three times to change to CTD instruction.

6. Press the RIGHT arrow button once to select the CLK parameter field. This is the trigger for counting. Press the UP arrow button once to change CLK parameter to I01.

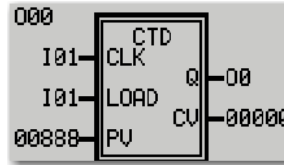

7. Press the RIGHT arrow button once to select the LOAD parameter field. This input reloads the preset value PV. Press the UP arrow button once to select I02.

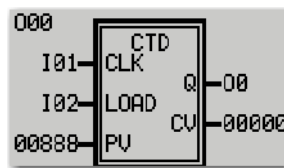

8. Press the RIGHT arrow button three times to move to the first non-zero entry on the PV (Preset Value for the counter) parameter field.
  - a. Press the UP arrow button twice to change this digit to zero.
  - b. Press the RIGHT arrow button once to get to the next non-zero digit in the PV field.
  - c. Press the UP arrow button three times to get the digit value of 1.
  - d. Press the RIGHT arrow button once to position to the next digit in the PV field.
  - e. Press the UP arrow button twice to make this digit a zero.

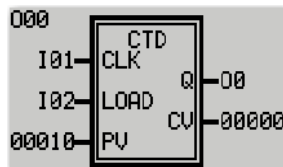

9. Press the OK button to submit the parameter changes. A screen confirms your request to save the parameter changes. Press the OK button to save the changes.

## Test the CTD Predefined Function

The CTD instruction decrements the counter from a given value down to 0 whenever input CLK makes a transition from low to high, and energizes the output when  $CV \leq 0$ . To test the operation, we connect a count push button to I01, a load push button to I02, and a pilot light to output O00.

1. Press the ESC button to return to the Main Menu.



2. Press the UP arrow button once to select Mode Switch and press the OK button.
3. Press the DOWN arrow button once to select RUN mode. Press the OK button.
4. Press the OK button to confirm the RUN mode selection.
5. The screen indicates that the controller is in RUN mode. Press the ESC button to return to the Main Menu.
6. Press the DOWN arrow button once and press the OK button to select SR FUNCTION.
7. Press the load push button connected to I02. The current value CV reloads to 00010, and the pilot light turns off. Then, release the load push button.



8. Press and release the count push button connected to I01. The current value CV decrements to 00009.  
Repeat the step 8 nine times, until CV decrements to 00000.  
When CV = 0, the output O00 is energized, and the pilot light turns off.



## Configure TONOFF

### TONOFF – Sample Parameter Configuration

Parameter field	Configuration value
Q	Q01
IN	I03
Time Resolution	SS:MS
PT	15:000
PTOFF	20:000

1. Power up the Micro810 controller.  
The Micro810 splash screen briefly appears after power up.
2. The status display shows the PROG mode, the day and time, and the I/O status. Press the ESC and OK buttons at the same time to navigate to the Main Menu.
3. Press the DOWN arrow button once to select SR Function. Press the OK button. The function block for controlling Output 0 is displayed.
4. Press the UP arrow button once to select Output 1 (CTU).
5. Press the RIGHT arrow button once to select the CTU instruction parameter field.

6. Press the DOWN arrow button twice to go to TONOFF instruction.
7. Press the RIGHT arrow button once to select the IN parameter field. This input marks the start for the internal timer.  
Press the UP arrow button once to change IN parameter value to I03.
8. Press the RIGHT arrow button once to select the Time-Resolution parameter field. This input determines the unit of internal timer.  
Press the DOWN arrow button once to change time setting to SS:MS.

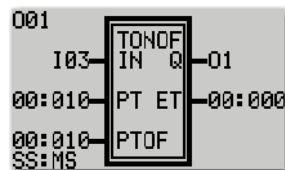

9. Press the RIGHT arrow button once to select the first entry in PT parameter field.
  - a. Press the UP arrow button once to get the digit value of 1.
  - b. Press the RIGHT arrow button once to select the second digit entry in PT parameter field.
  - c. Press the UP arrow button five times to get the digit value of 5.
  - d. Press the RIGHT arrow button twice to select the fourth digit entry in PT parameter field.
  - e. Press the DOWN arrow button once to get the digit a zero.

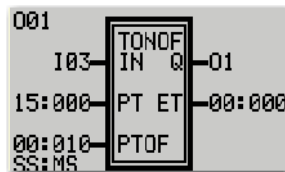

10. Press the RIGHT arrow button once to select the first digit entry in PTOF parameter field.
  - a. Press the UP arrow button twice to get the digit value of 2.
  - b. Press the RIGHT arrow button 3 times to go to the fourth digit entry for the PTOF parameter field.
  - c. Press the DOWN arrow button once to make this digit a zero.

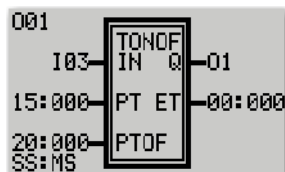

11. Press the OK button to submit the parameter changes.  
A screen confirms your request to save the parameter changes. Press the OK button to save the changes.

## Test the TONOFF Predefined Function

The TONOFF instruction starts an internal timer up to a given value PT when input IN makes a transition from low to high, and energizes the output when  $ET = PT$ .

Restart the internal timer up to a given value PTOF when input IN makes a transition from high to low, and de-energize the output when  $EP = PTOF$ . To test the operation, we connect a push button to I03, and a pilot light to output O01.

1. Press the ESC button to return to the Main Menu.
2. Press the UP arrow button once to select Mode Switch. Press THE OK button.
3. Press the DOWN arrow button once to select RUN mode. Press the OK button.
4. Press the OK button to confirm the RUN mode selection.
5. The screen indicates that the controller is in RUN mode. Press the ESC button to return to the Main Menu.
6. Press the DOWN arrow button once to select SR FUNCTION. Press the OK button.
7. Press the UP arrow button once to select Output 1.
8. Press the push button connected to I03. The elapsed time ET starts to elapse.
9. When the current elapsed time  $ET =$  programmed time PT, the output O01 is energized, and the pilot light turns on.



10. Release the push button connected to I03. The elapsed time ET restarts to elapse.  
When the current elapsed time ET = programmed time PTOF, the output O01 is de-energized, and the pilot light turns off.

## Configure Pulse Timing (TP)

### TP – Sample Parameter Configuration

Parameter Field	Configuration Value
Q	Q02
IN	I03
Time Resolution	SS:MS
PT	15:000

1. Power up the Micro810 controller.  
The Micro810 splash screen briefly appears.
2. The status display shows PROG mode, the day and time, and the I/O status. Press the ESC and OK buttons at the same time to navigate to the Main Menu.
3. Press the DOWN arrow button once to select SR Function. Press the OK button. The function block for controlling Output 0 is displayed.
4. Press the UP arrow button twice to select Output 2 (TOW). To switch to TP instruction:
  - a. Press the RIGHT arrow button once to select the TOW instruction parameter field.
  - b. Press the DOWN arrow button four times to switch to TP instruction.
5. Press the RIGHT arrow button once to select the IN parameter field. This marks the start of the internal timer.
6. Press the RIGHT arrow button once to select the Time-Resolution parameter field. This input determines the unit of internal timer. Press the DOWN arrow button once to change time setting to SS:MS.

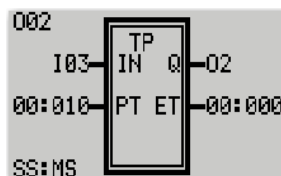

7. Press the RIGHT arrow button once to select the first entry in PT parameter field.
  - a. Press the UP arrow button once to change this digit value to 1.
  - b. Press the RIGHT arrow button once to select the second digit entry in PT parameter field.
  - c. Press the UP arrow button five times to change this digit value to 5.

- d. Press the RIGHT arrow button twice to select the fourth digit entry in PT parameter field.
- e. Press the DOWN arrow button once to get the digit value of zero.

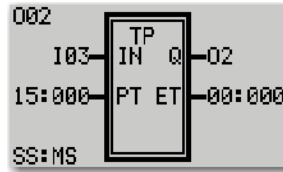

8. Press the OK button to submit the parameter changes.  
A screen confirms your request to save the parameter changes. Press the OK button to save the changes.

## Test the TP Predefined Function

The TP instruction starts an internal timer when input IN makes a transition from low to high, and energizes the output at the same time. When the elapsed time ET increments up to the given value PT, it de-energizes the output. To test the operation, we connect a push button to I03, and a pilot light to output O02.

1. Press the ESC button to return to the Main Menu.
2. Press the UP arrow button to select Mode Switch. Press the OK button.
3. Press the DOWN arrow button to select RUN mode. Press the OK button.
4. Press the OK button to confirm the RUN mode selection.
5. The screen indicates that the controller is in RUN mode. Press the ESC button to return to the Main Menu.
6. Press the DOWN arrow button to select SR FUNCTION. Press the OK button.
7. Press the UP arrow button twice to select Output 2.

8. Press the push button connected to I03. The elapsed time ET starts to elapse and the pilot light turns on.

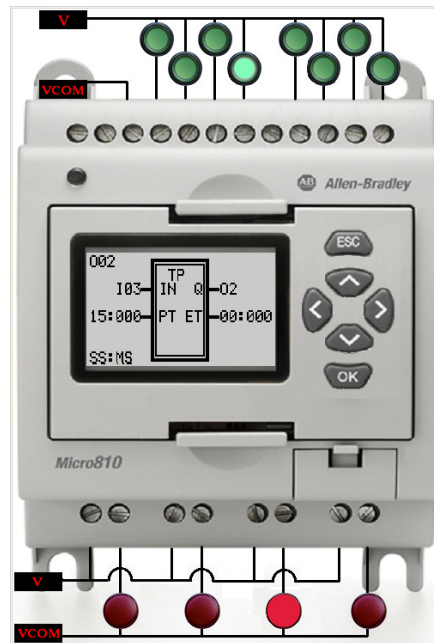

When the current elapsed time ET = programmed time PT, the output Q02 is de-energized, and the pilot light turns off.

## Configure TOF

### TOF – Sample Parameter Configuration

Parameter field	Config value
Q	Q03
IN	I02
Time Resolution	SS:MS
PT	15:000

1. Power up the Micro810 controller.  
The Micro810 splash screen briefly appears after power up.
2. The status display shows PROG mode, the day and time, and the I/O status. Press the ESC and OK buttons at the same time to navigate to the Main Menu.
3. Press the DOWN arrow button once to select SR Function. Press the OK button. The function block for controlling Output 0 is displayed.
4. Press the DOWN arrow button once to select Output 3.
  - a. Press the RIGHT arrow button once to select the DOY instruction parameter field.
5. Press the UP arrow button once to go to TOF instruction.

6. Press the RIGHT arrow button once to select the IN parameter field. This marks the start for the Off-delay timer.  
Press the DOWN arrow button four time to change IN parameter value to I02.

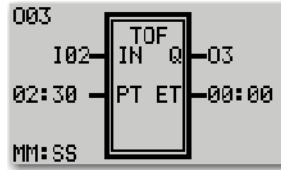

7. Press the RIGHT arrow button once to select the Time-Resolution parameter field. This input determines the unit of Off-delay timer.  
Press the DOWN arrow button once to change time parameter setting to SS:MS.

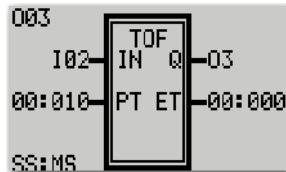

8. Press the RIGHT arrow button once to select the first digit entry for the PT parameter field.
  - a. Press the UP arrow button once to get the digit value of 1.
  - b. Press the RIGHT arrow button once to select the second entry in PT parameter field.
  - c. Press the UP arrow button five times to get the digit value of 5.
  - d. Press the RIGHT arrow button twice to select the fourth digit entry in PT parameter field.
  - e. Press the DOWN arrow button once to get the digit value of zero.

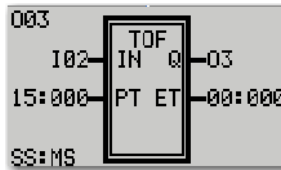

9. Press the OK button to submit the parameter changes.  
A screen confirms your request to save the parameter changes. Press the OK button to save the changes.

## Test the TOF Predefined Function

The TOF instruction energizes the output when input IN makes a transition from low to high. Then, it starts the Off-delay timer when input IN makes a transition from high to low. When the elapsed time ET increments up to the



given value PT, it de-energizes the output. To test the operation, we connect a push button to I02, and a pilot light to output O03.

1. Press the ESC button to return to the Main Menu.
2. Press the UP arrow button once to select Mode Switch. Press the OK button.
3. Press the DOWN arrow button once to select RUN mode. Press the OK button.
4. Press the OK button to confirm the RUN mode selection.
5. The screen indicates that the controller is in RUN mode. Press the ESC button to return to the Main Menu.
6. Press the DOWN arrow button once to select SR FUNCTION. Press the OK button.
7. Press the DOWN arrow button once to select Output 3.
8. Press the push button connected to I02, the output O03 is energized and the pilot light turns on.



9. Release the push button connected to I02. The ET parameter starts to elapse. When the current  $ET = PT$ , the output O03 is de-energized, and the pilot light turns off.

## Flash Update the Micro800 Firmware

---

**IMPORTANT** When the controller is in Remote Run mode, and it is password protected, the user needs to supply the correct password to switch to Remote Program to enable upgrade.

The Micro810 controller does not include a reset-to-factory-default button and a mechanical switch to change modes that will override password protection to allow a flash upgrade.

Thus, it is always important to have the correct passwords available to switch modes and enable an upgrade.

---

This quick start will show you how to flash update the firmware for a Micro800 controller using Connected Components Workbench software release 10 or later.

From Connected Components Workbench software release 10 onwards, there are two options you can select when flash updating the firmware:

- Upgrade or Downgrade – For Micro810 controllers, this option clears the controller’s existing configuration, Ethernet settings, and password.
- Reset – For Micro810 controllers, this option is not available. Selecting this option will prompt an error dialog box.

The procedure to flash update the controller is similar for both options.

---

**IMPORTANT** To successfully flash update your controller over USB, connect only one controller to your computer, and do not perform the flash update in a virtual machine such as VMware.

---

To begin, launch the Connected Components Workbench software:

1. In the menu, select Device -> Update Firmware -> Upgrade or Downgrade...  
Alternatively, in the Project Organizer, right-click the controller and select Update Firmware -> Upgrade or Downgrade...

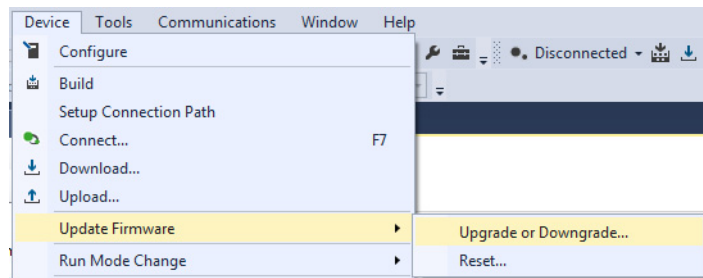

2. If your project does not have a connection path to the controller, the Connection Browser dialog appears. Select your controller, then click OK.

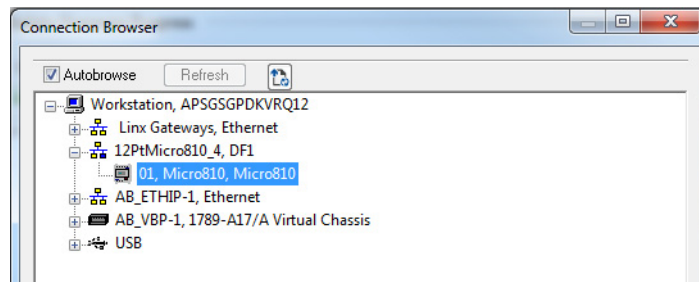

3. In the Upgrade or Downgrade Firmware dialog box, select the desired Target Revision to flash update the controller.

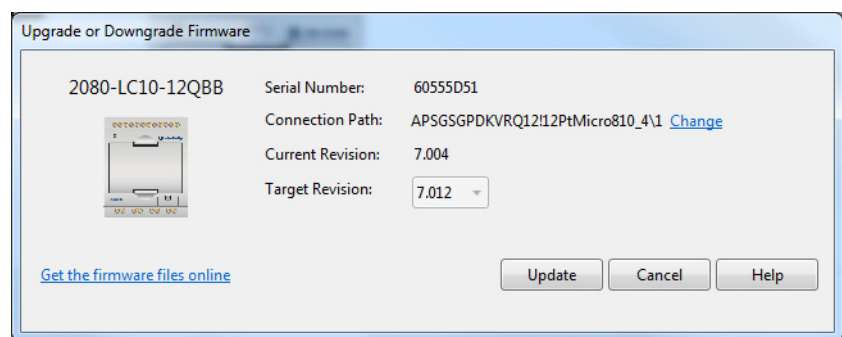

If the desired firmware revision is not shown in the drop-down list, you can download that firmware revision by clicking the “Get the firmware files online” link.

You can also change the Connection Path by clicking the “Change” link.

4. When you have confirmed the settings, click Update to begin flash updating the controller.  
The update progress is shown in the dialog box.

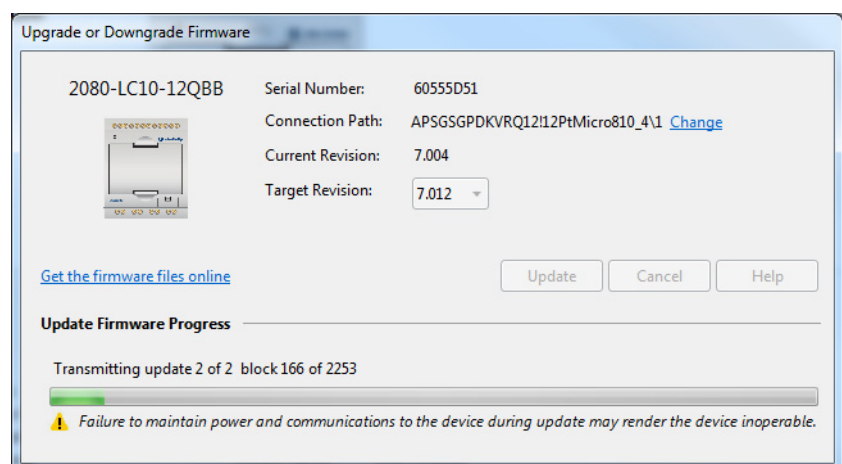

5. After the update is completed, the status is shown in the dialog box.

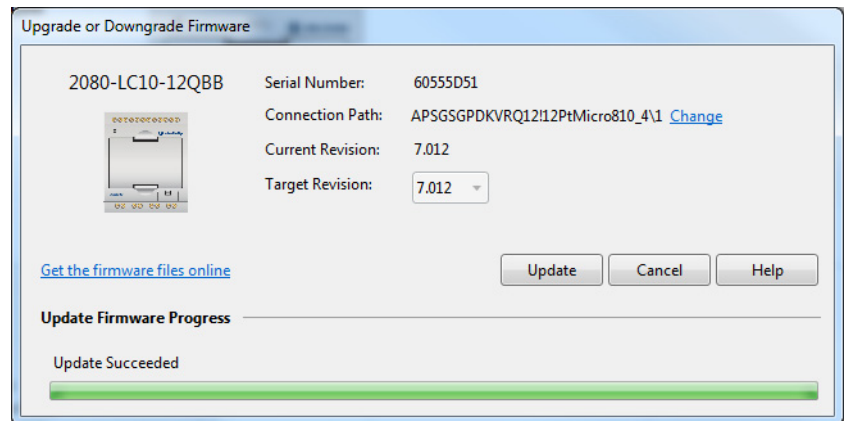

## Establish Communication Between RSLinx and a Micro810 12-point controller through USB

This quickstart shows you how to get RSLinx RSWho to communicate with a Micro810 12-point controller through USB. Micro810 controller uses the 12PtM810\_XXXXX driver.

Normally, RSLinx Classic is installed as part of the Connected Components Workbench software installation process. The minimum version of RSLinx Classic with full Micro800 controller support is 2.57, build 15 (released March 2011).

1. Power up the Micro810 12-point controller.
2. Plug the 2080-USBADAPTER into the Micro810 and then plug the USB A/B cable directly between your PC and the adapter.
3. Click No, not this time and Next when you are prompted to search for software through Windows Update.



4. Click Next to continue.

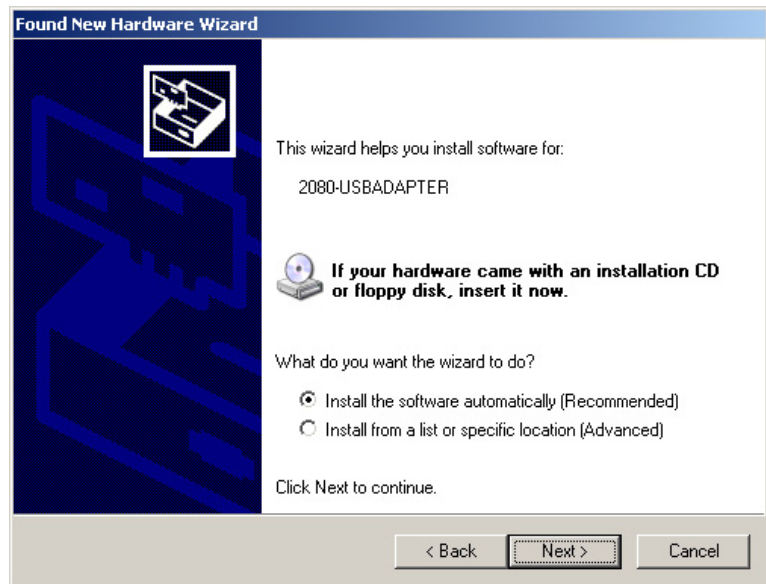

5. Click Finish after Found New Hardware Wizard completes installation of the software.

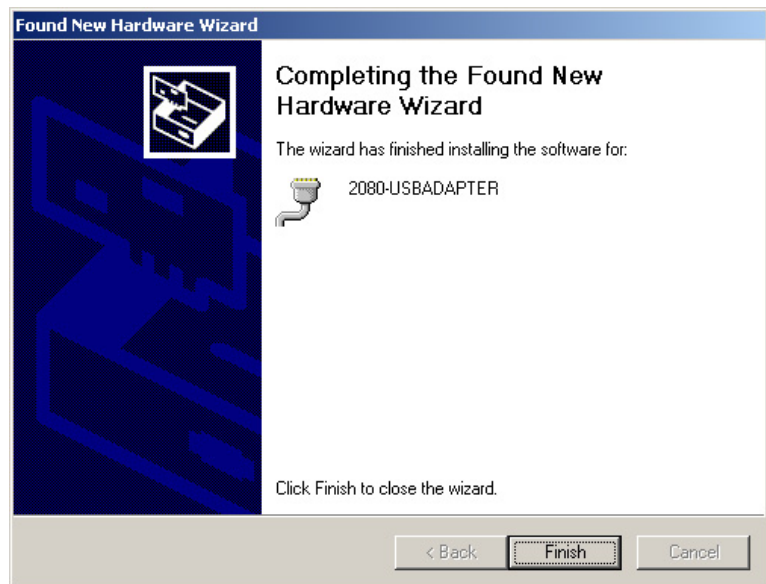

6. Open RSLinx Classic and run RSWho by clicking the  icon.
7. The Micro810 controller shows up under the 12PtM810 driver.

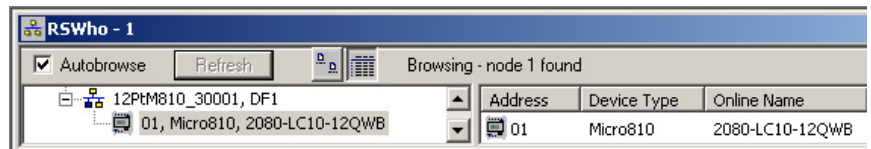

8. You can now use ControlFLASH or Connected Components Workbench to communicate with the Micro810 controller.

## Forcing I/O

Forcing is only possible with I/O and does not apply to user defined variables and non-I/O variables.

Inputs are logically forced, so LED status indicators do not show forced values, but the inputs in the user program are forced.

Unlike inputs, outputs are physically forced, so LED status indicators do show forced values. The user program does not use forced values.

The following diagram illustrates forcing behavior.

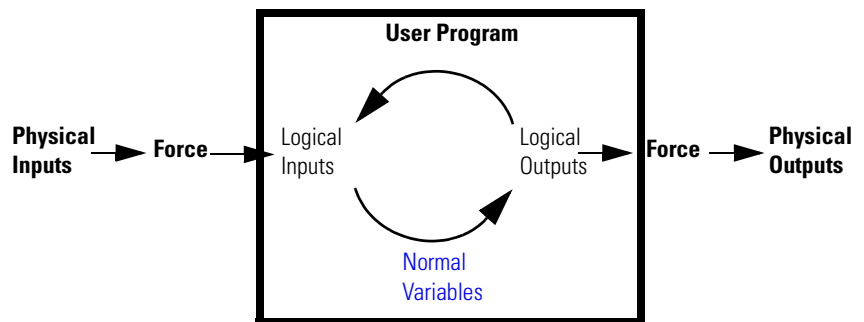

- Normal, non-physical internal variables cannot be forced

### Check if Forces (locks) are Enabled

If Connected Components Workbench is available, check the Variable Monitor while debugging online. Forcing is performed by first Locking an I/O variable and then setting the Logical Value for Inputs and Physical Value for Outputs.

Remember you cannot force a Physical Input and cannot force a Logical Output.

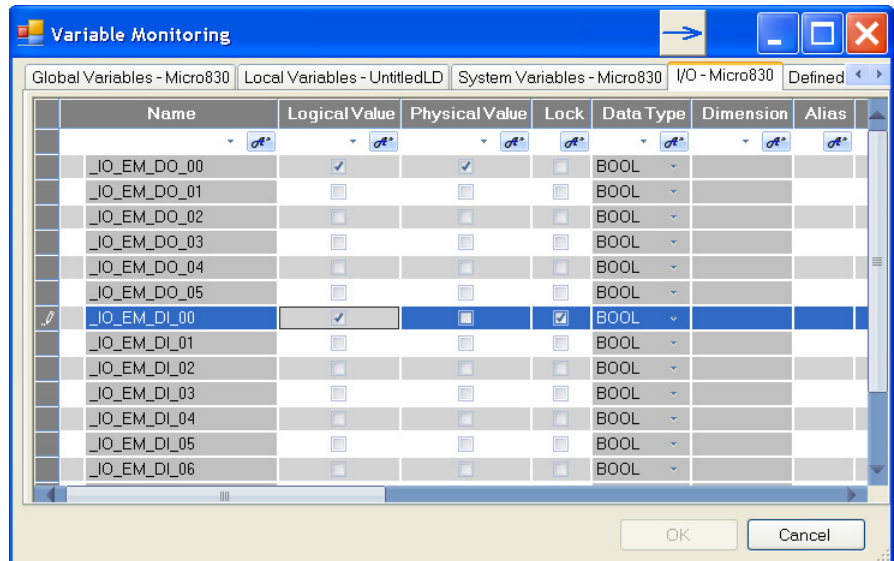

In many cases, the front of the controller is not visible to the operator and Connected Components Workbench is not online with the controller. If you want the force status to be visible to the operator, then the User Program must read the force status using the SYS\_INFO function block and then display the force status on something that the operator can see, such as the human machine interface (HMI), or stack light. The following is an example program in Structured Text.

```

1  (* Read System Information including Force Enable bit *)
2  SYS_INFO_1(TRUE);
3
4  (* Turn on Warning Light if Forces are Enabled *)
5  IF SYS_INFO_1.Sts.ForcesInstall = TRUE THEN
6    _IO_EM_DO_05 := TRUE;
7  ELSE
8    _IO_EM_DO_05 := FALSE;
9  END_IF;

```

If the front of the controller is visible, and not blocked by the cabinet enclosure, Micro830 and higher controllers have a force LED indicator.

### I/O Forces After a Power Cycle

After a controller is power cycled, all I/O forces are cleared from memory.



## IPID Function Block

This function block diagram shows the arguments in the IPIDCONTROLLER function block.

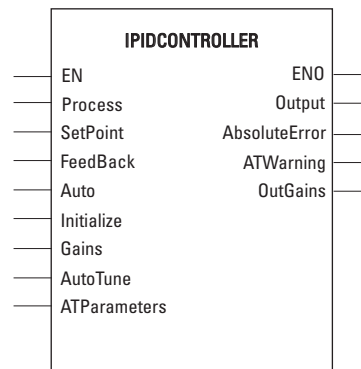

The following table explains the arguments used in this function block.

### IPIDCONTROLLER Arguments

Parameter	Parameter Type	Data Type	Description
EN	Input	BOOL	Function block enable TRUE = Execute function. FALSE = Do not execute function. Applicable to Ladder Diagram programs.
Process	Input	REAL	Process value, which is the value measured from the process output.
SetPoint	Input	REAL	The set point value for the process.
Feedback	Input	REAL	Feedback signal, which is the value of the control variable applied to the process. For example, the feedback can be IPIDCONTROLLER output.
Auto	Input	BOOL	Operating modes of PID controller: TRUE = Normal operation of PID. FALSE = Output tracks Feedback.
Initialize	Input	BOOL	A change in value (TRUE to FALSE or FALSE to TRUE) causes the controller to eliminate any proportional gain during that cycle. It also initializes AutoTune sequences.
Gains	Input	GAIN_PID	Gains PID for IPIDCONTROLLER. Use the GAIN_PID data type to define the parameters for the Gains input.

**IPIDCONTROLLER Arguments**

Parameter	Parameter Type	Data Type	Description
AutoTune	Input	BOOL	TRUE = When AutoTune is TRUE, and Auto and Initialize are FALSE, the AutoTune sequence is started. FALSE = Do not start AutoTune.
ATParameters	Input	AT_Param	AutoTune parameters Use AT_Param data type to define the parameters for the ATParameters input.
Output	Output	Real	Output value from the controller.
AbsoluteError	Output	Real	Absolute error (Process - SetPoint) from the controller.
ATWarnings	Output	DINT	Warning for the AutoTune sequence. Possible value are: 0 = No auto tune done. 1 = In auto tune mode. 2 = Auto tune done. -1 = Error 1: Input automatically set to TRUE, no auto tune possible. -2 = Error 2: Auto tune error, the ATDynamSet expired.
OutGains	Output	GAIN_PID	Gains calculated from AutoTune Sequences. Use GAIN_PID data type to define the OutGains output.
ENO	Output	BOOL	Enable out. Applicable to Ladder Diagram programs.

**GAIN\_PID Data Type**

Parameter	Type	Description
DirectActing	BOOL	Types of acting: TRUE = Direct acting, output moves same direction as error. That is, the actual process value is greater than the SetPoint and the appropriate controller action is to increase the output. For example, Chilling. FALSE = Reverse acting, output moves opposite direction as error. That is, the actual process value is greater than the Setpoint and the appropriate controller action is to decrease the output. For example, Heating.
ProportionalGain	REAL	Proportional gain for PID ( $\geq 0.0001$ ). <b>Proportional gain for PID (P_Gain)</b> A higher proportional gain causes a larger change in the output based upon the difference between the PV (measured process value) and SV (set point value). The higher the gain, the faster the error is decreased, but this may result in instability such as oscillations. The lower the gain, the slower the error is decreased, but the system is more stable and less sensitive to large errors. The P_Gain usually is the most important gain to adjust and the first gain to adjust while tuning.

**GAIN\_PID Data Type**

Parameter	Type	Description
TimeIntegral	REAL	Time integral value for PID ( $\geq 0.0001$ ). <b>Time integral value for PID</b> A smaller integral time constant causes a faster change in the output based upon the difference between the PV (measured process value) and SV (set point value) integrated over this time. A smaller integral time constant decreases the steady state error (error when SV is not being changed) but increases the chances of instability such as oscillations. A larger integral time constant slows down the response of the system and make it more stable, but PV approaches the SV at a slower rate.
TimeDerivative	REAL	Time derivative value for PID ( $> 0.0$ ). <b>Time derivative value for PID (Td)</b> A smaller derivative time constant causes a faster change in the output based upon the rate of change of the difference between PV (measured process value) and SV (set point value). A smaller derivative time constant makes a system more responsive to sudden changes in error (SV is changed) but increases the chances of instability such as oscillations. A larger time constant makes a system less responsive to sudden changes in error and the system is less susceptible to noise and step changes in PV. TimeDerivative (Td) is related to the derivative gain but allows the derivative contribution to PID to be tuned using time so the sample time must be taken into consideration.
DerivativeGain	REAL	Derivative gain for PID ( $\geq 0.0$ ). <b>Derivative gain for PID (D_Gain)</b> A higher derivative gain causes a larger change in the output based upon the rate of change of the difference between the PV (measured process value) and SV (set point value). A higher gain makes a system more responsive to sudden changes in error but increases the chances of instability such as oscillations. A lower gain makes a system less responsive to sudden changes in error and makes the system less susceptible to noise and step changes in the PV. <b>If derivative gain is set to zero, it disables the derivative portion of the PID.</b>

**AT\_Param Data Type**

Parameter	Type	Description
Load	REAL	Load parameter for auto tuning. This is the output value when starting AutoTune.
Deviation	REAL	Deviation for auto tuning. This is the standard deviation used to evaluate the noise band needed for AutoTune (noise band = $3 * \text{Deviation}$ ) <sup>(1)</sup>
Step	REAL	Step value for AutoTune. Must be greater than noise band and less than $\frac{1}{2}$ load.
ATDynamSet	REAL	Waiting time in seconds before abandoning auto tune.
ATReset	BOOL	Determines whether the output value is reset to zero after an AutoTune sequence: TRUE = Reset output to zero. FALSE = Leaves output at Load value.

(1) The application engineer can estimate the value of ATParams.Deviation by observing the value of Proces input. For example, in a project that involves the control of temperature, if the temperature stabilizes around 22 °C, and a fluctuation of 21.7...22.5 °C is observed, the value of ATParams.Deviation will be  $(22.5-21.7)/2=0.4$ .

## How to AutoTune

Before you autotune, you need to:

- Verify that your system is constant when there is no control. For example, for temperature control, process value should remain at room temperature when there is no control output.
- Configure the set point to 0.
- Set Auto Input to False.
- Set the Gain parameter as follows:

### GAIN Parameter Values

GAIN Parameter	Value
DirectActing	According to operation: TRUE (for example, Cooling), or FALSE (for example, Heating)
DerivativeGain	0.5
ProportionalGain	0.0001
TimeIntegral	0.0001
TimeDerivative	0.0

- Set the AT\_Parameter as follows:

### AT\_Parameter Values

AT Parameter	Recommendation
Load	Every 'Load' provides a saturated process value over a period of time. Adjust the load to the value for the saturated process value you want.  <b>IMPORTANT:</b> If a load of 40 gives you a process value of 30 °C over a period of time, and you want to tune your system to 30 °C, you should set the load to 40.
Deviation	This parameter plays a significant role in the autotune process. The method of deriving this value is explained later in this section. It is not necessary to set this parameter prior to autotuning. However, if you already know the deviation, it is fine to set it first.
Step	Step value should be between 3*Deviation and ½ load. The step provides an offset for the load during autotuning. It should be set to a value high enough to create a significant change in process value.
ATDynamSet	Set this value to a reasonably long time for the autotune process. Every system is different, so allow more time to a system with a process value that takes longer to react to change.
ATReset	Set this parameter to TRUE to reset the output to zero after the autotune process completes. Set this parameter to FALSE to leave the output at load value after the autotune process completes.

During autotune, the controller will automatically set the process value to zero. To autotune, perform the following steps:

1. Set the Initialize input to TRUE.
2. Set the AutoTune input to TRUE.
3. Wait for the Process input to stabilize or reach a steady state.

4. Note the temperature fluctuation of the process value.
5. Calculate deviation value with reference to the fluctuation. For example, if the temperature stabilizes around 22 °C (72 °F) with a fluctuation of 21.7...22.5 °C (71...72.5 °F), the value of 'ATParams.Deviation' is:

$$\text{For } ^\circ\text{C: } \frac{22.5 - 21.7}{2} = 0.4 \quad \text{For } ^\circ\text{F: } \frac{72.5 - 71}{2} = 0.75$$

6. Set the deviation value, if you have not set it yet.
7. Change the initialize input to FALSE.
8. Wait until the 'AT\_Warning' shows 2. The autotune process is successful.
9. Get the tuned value from the 'OutGains'.

## How Autotune Works

The auto tune process begins when the 'Initialize' is set to FALSE (Step 7.) At this moment, the control output increases by the amount of 'Step' and the process waits for the process value to reach or exceeds 'first peak'.

First peak is defined as:

*For Direct Operation: First peak = PV1 - (12 x Deviation)*

*For Reverse Operation: First peak = PV1 + (12 x Deviation)*

Where PV1 is the process value when Initialize is set to FALSE.

Once the process value reaches first peak, the control output reduces by the amount of Step and waits for the process value to drop to the second peak.

Second peak is defined as:

*For Direct Operation: Second peak = PV1 - (3 x Deviation)*

*For Reverse Operation: Second peak = PV1 + (3 x Deviation)*

Once the process value reaches or falls below second peak, calculations commence and a set of gain will be generated to parameter OutGains.

## Troubleshooting an Autotune Process

You can tell what is going on behind the autotune process from the sequences of control output. Here are some known sequences of control output and what it means if autotune fails. For the ease of illustrating the sequence of control output, we define:

Load: 50

Step: 20

**Output Sequence 1: 50 -> 70 -> 30**

Sequence Condition	Autotune Result	Action for Autotune Fail
Process value reached 'first peak' and 'second' peak in time	Likely successful	NA

**Output Sequence 2: 50 -> 70 -> 50**

Sequence Condition	Autotune Result	Action for Autotune Fail
Process value not able to reach 'first peak'	Likely unsuccessful	Reduce Deviation or Increase Step

**Output Sequence 3: 50 -> 70 -> 30 -> 50**

Sequence Condition	Autotune Result	Action for Autotune Fail
Process value not able to reach second peak	Likely unsuccessful	Increase Deviation or increase Step

**Output Sequence 4: 50 -> 70**

Sequence Condition	Autotune Result	Action for Autotune Fail
Process value not able to reach First peak in time	Likely unsuccessful	Increase ATDynamSet

## PID Application Example

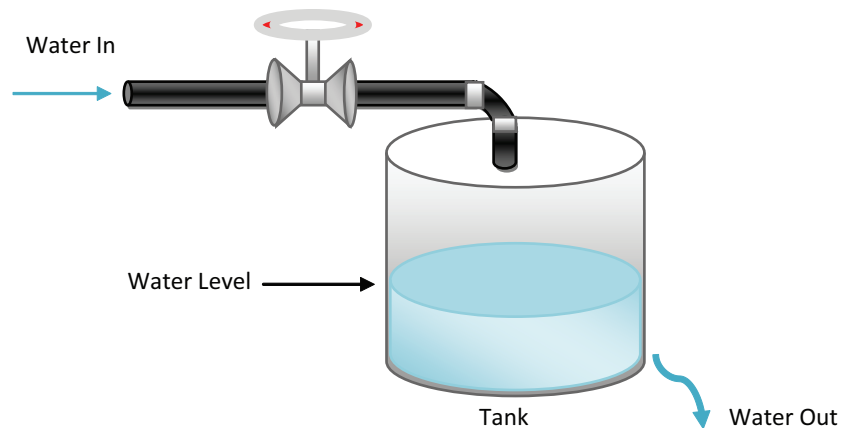

The illustration above shows a basic water level control system, to maintain a preset water level in the tank. A solenoid valve is used to control incoming water, filling the tank at a preset rate. Similarly, outflowing water is controlled at a measurable rate.

### *IPID Autotuning for First and Second Order Systems*

Autotune of IPID can only work on first and second order systems.

A first order system can be described by a single independent energy storage element. Examples of first order systems are the cooling of a fluid tank, the flow of fluid from a tank, a motor with constant torque driving a disk flywheel or an electric RC lead network. The energy storage element for these systems are heat energy, potential energy, rotational kinetic energy and capacitive storage energy, respectively.

This may be written in a standard form such as  $f(\tau) = \tau dy/dt + y(\tau)$ , where  $\tau$  is the system time constant,  $f$  is the forcing function and  $y$  is the system state variable.

In the cooling of a fluid tank example, it can be modeled by the thermal capacitance  $C$  of the fluid and thermal resistance  $R$  of the walls of the tank. The system time constant will be  $RC$ , the forcing function will be the ambient temperature and the system state variable will be the fluid temperature.

A second order system can be described by two independent energy storage elements which exchange stored energy. Examples of second order systems are a motor driving a disk flywheel with the motor coupled to the flywheel via a shaft with torsional stiffness or an electric circuit composed of a current source driving a series LR (inductor and resistor) with a shunt C (capacitor). The energy storage elements for these systems are the rotational kinetic energy and torsion spring energy for the former and the inductive and capacitive storage energy for the latter. Motor drive systems and heating systems can be typically modeled by the LR and C electric circuit.

### PID Code Sample

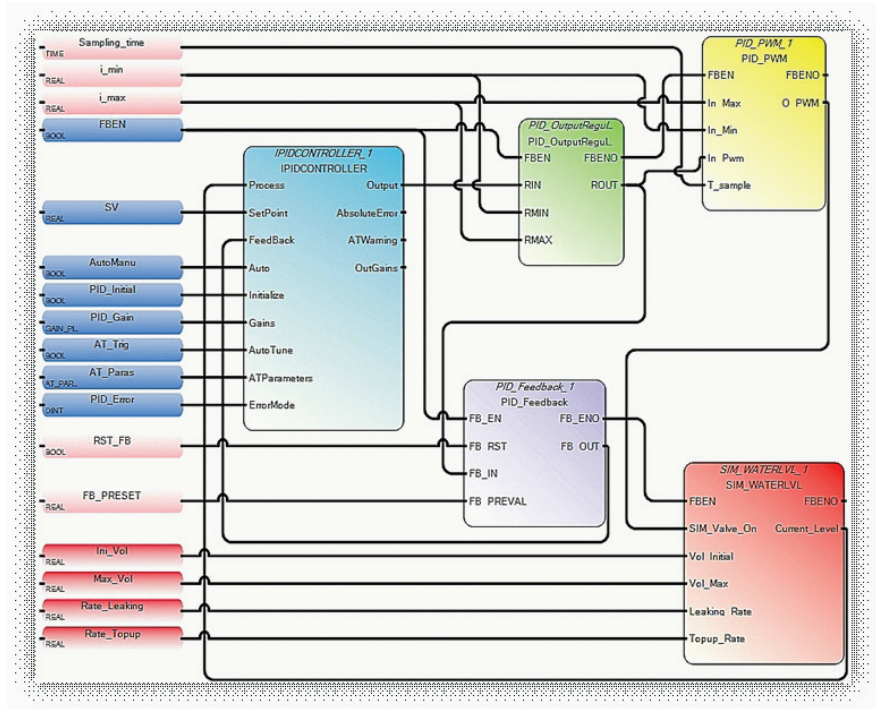

The illustration above shows sample code for controlling the PID application example shown before. Developed using Function Block Diagrams, it consists of a pre-defined function block, IPIDCONTROLLER, and four user-defined function blocks. These four are:

- PID\_OutputRegulator**  
 This user-defined function block regulates the output of IPIDCONTROLLER within a safe range to ensure that there is no damage to the hardware used in the process.

IF  $RMIN \leq RIN \leq RMAX$ , then  $ROUT = RIN$ ,  
 IF  $RIN < RMIN$ , then  $ROUT = RMIN$ ,  
 IF  $RIN > RMAX$ , then  $ROUT = RMAX$ .

- PID\_Feedback**  
 This user defined function block acts as a multiplexer.

IF "FB\_RST" is false,  $FB\_OUT = FB\_IN$ ;  
 If "FB\_RST" is true, then  $FB\_OUT = FB\_PREVAL$ .

- PID\_PWM**  
 This user defined function block provides a PWM function, converting a real value to a time related ON/OFF output.
- SIM\_WATERLVL**  
 This user defined function block simulates the process depicted in the application example shown before.



---

**IMPORTANT** User Program Scan Time is Important

The autotuning method needs to cause the output of the control loop to oscillate. In order to identify the oscillation period, the IPID must be called frequently enough to be able to sample the oscillation adequately. The scan time of the user program must be less than half the oscillation period. In essence the Shannon, or Nyquist-Shannon, or the sampling theorem must be adhered to.

In addition, it is important that the function block is executed at a relatively constant time interval.

---

**Notes:**

## Numerics

- 1.5" LCD Display and Keypad Module** 58
- 1492-EAHJ35** 16
- 1492-EAJ35** 16
- 2080-LC10-12QBB** 1
- 2080-LC10-12QW** 1
- 2080-PS120-240VAC** 15

## A

- About Accessories** 57
- About Your Controller** 3
- Accessories** 57
- Additional Resources** iii
- Agency Certifications** 3
- analog cable grounding** 23
- analog channel wiring guidelines** 22
- analog inputs**
  - analog channel wiring guidelines 22
- AutoTune** 108

## B

- before calling for assistance** 36
- Belden cable #8761** 22

## C

- calling for assistance** 36
- CE mark** 3, 4
- Compliance to European Union Directives** 3
  - Low Voltage Directive 4
- Connected Components Workbench** iv
  - controller password 43
- controller**
  - description 1
  - grounding 20
  - I/O wiring 21
  - minimizing electrical noise 21
  - mounting dimensions 15
  - preventing excessive heat 10
- controller password** 43
  - change 68
  - clear 69
  - compatibility 44
  - configure 47
  - set 66
- Countdown (CTD) Function Block** 87
- Count-Up (CTU) Function Block** 71
- current cycle time** 38
- current relay chart**
  - high 52
  - low 53
- cycle counter** 38

## D

- DIN Rail Mounting** 15
- disconnecting main power** 7

## E

- EMC Directive** 4
- emergency-stop switches** 11
- Error codes** 26
- error codes** 27
- error recovery model** 35
- Establishing Communications Between RSLinx and Micro810 through USB** 101
- European Union Directive compliance** 3
  - EMC Directive 4
- exclusive access** 43
- execution rules** 38
- external AC power supply** 57

## F

- Flash Updating Micro800 Firmware** 98
- Forcing I/Os** 103

## G

- general considerations** 4
- grounding the controller** 20
- Guidelines and Limitations** 41

## H

- hardware features** 1
- heat protection** 10
- high current relay chart** 52

## I

- input states on power down** 10
- inrush current** 9
- installation**
  - considerations 4
  - controller mounting dimensions 15
  - module spacing 15
- IPID Function Block** 105
- IPIDCONTROLLER** 105
  - parameters 105
- isolation transformer** 9
  - power considerations 9

**L****LCD password** 61

- activate 62
- change 63
- deactivate 62
- delete 64

**low current relay chart** 53**M****master control relay** 10

- emergency-stop switches 11
- using ANSI/CSA symbols schematic 14
- using IEC symbols schematic 13

**master control relay circuit**

- periodic tests 8

**memory allocation** 40**Micro800 power supply** 1**Micro810 12-Point Controllers** 1**Micro810 High Current Relay Chart** 52**Micro810 Low Current Relay Chart** 54**minimizing electrical noise** 21**minimizing electrical noise on analog channels** 22**module spacing** 15**motor starters (bulletin 509)**

- surge suppressors 19

**mounting dimensions** 15**P****panel mounting** 16**PID Application Example** 110**PID Code Sample** 112**power considerations** 9

- input states on power down 10
- isolation transformers 9
- loss of power source 9
- other line conditions 10
- overview 9
- power supply inrush 9

**power distribution** 8**power source**

- loss of 9

**power supply inrush**

- power considerations 9

**preventing excessive heat** 10**program execution** 37**Program Organizational Unit (POU)** 41**Q****Quickstarts** 61**R****relay function block**

- CTD 70
- CTU 70
- DOY 70
- TOF 70
- TON 70
- TONOF 70
- TOW 70
- TP 70

**RSLinx Classic** 101**Running Programs with Micro800** 37**S****safety circuits** 8**safety considerations** 6

- disconnecting main power 7
- hazardous location 7
- periodic tests of master control relay circuit 8
- power distribution 8
- safety circuits 8

**Specifications** 49**specifications**

- External AC Power Supply 56
- Micro810 Controllers 49

**status indicators** 25

- on the Controller 25
- on the LCD Module 25

**Structured Text** 41**surge suppression** 18

- for motor starters 19
- recommended surge suppressors 19
- using 17

**T****Testing the Count-Up (CTU) Predefined Function** 73**Troubleshooting** 25**U****USB Adapter** 60**User Defined Function (UDF)** 38**User Defined Function Block (UDFB)** 38**W****wiring**

- diagrams 20
- examples 23
- recommendation 17
- your controller 17



# Rockwell Automation Support

Rockwell Automation provides technical information on the Web to assist you in using its products.

At <http://www.rockwellautomation.com/support/>, you can find technical manuals, a knowledge base of FAQs, technical and application notes, sample code and links to software service packs, and a MySupport feature that you can customize to make the best use of these tools.

For an additional level of technical phone support for installation, configuration, and troubleshooting, we offer TechConnect support programs. For more information, contact your local distributor or Rockwell Automation representative, or visit <http://www.rockwellautomation.com/support/>.

## Installation Assistance

If you experience a problem within the first 24 hours of installation, review the information that is contained in this manual. You can contact Customer Support for initial help in getting your product up and running.

United States or Canada	1.440.646.3434
Outside United States or Canada	Use the <a href="#">Worldwide Locator</a> at <a href="http://www.rockwellautomation.com/support/americas/phone_en.html">http://www.rockwellautomation.com/support/americas/phone_en.html</a> , or contact your local Rockwell Automation representative.

## New Product Satisfaction Return

Rockwell Automation tests all of its products to ensure that they are fully operational when shipped from the manufacturing facility. However, if your product is not functioning and needs to be returned, follow these procedures.

United States	Contact your distributor. You must provide a Customer Support case number (call the phone number above to obtain one) to your distributor to complete the return process.
Outside United States	Please contact your local Rockwell Automation representative for the return procedure.

## Documentation Feedback

Your comments will help us serve your documentation needs better. If you have any suggestions on how to improve this document, complete this form, publication [RA-DU002](#), available at <http://www.rockwellautomation.com/literature/>.

Rockwell Otomasyon Ticaret A.Ş., Kar Plaza İş Merkezi E Blok Kat:6 34752 İçerenköy, İstanbul, Tel: +90 (216) 5698400

**[www.rockwellautomation.com](http://www.rockwellautomation.com)**

### Power, Control and Information Solutions Headquarters

Americas: Rockwell Automation, 1201 South Second Street, Milwaukee, WI 53204-2496 USA, Tel: (1) 414.382.2000, Fax: (1) 414.382.4444

Europe/Middle East/Africa: Rockwell Automation NV, Pegasus Park, De Kleetlaan 12a, 1831 Diegem, Belgium, Tel: (32) 2 663 0600, Fax: (32) 2 663 0640

Asia Pacific: Rockwell Automation, Level 14, Core F, Cyberport 3, 100 Cyberport Road, Hong Kong, Tel: (852) 2887 4788, Fax: (852) 2508 1846

Rockwell Automation Publication 2080-UM001F-EN-E - November 2016

Supersedes Publication 2080-UM001E-EN-E - March 2015

Copyright © 2016 Rockwell Automation, Inc. All rights reserved.