

User Manual

Original Instructions



# PowerFlex 750-Series Safe Torque Off Option Module

Catalog Number 20-750-S



## Important User Information

Read this document and the documents listed in the additional resources section about installation, configuration, and operation of this equipment before you install, configure, operate, or maintain this product. Users are required to familiarize themselves with installation and wiring instructions in addition to requirements of all applicable codes, laws, and standards.

Activities including installation, adjustments, putting into service, use, assembly, disassembly, and maintenance are required to be carried out by suitably trained personnel in accordance with applicable code of practice.

If this equipment is used in a manner not specified by the manufacturer, the protection provided by the equipment may be impaired.

In no event will Rockwell Automation, Inc. be responsible or liable for indirect or consequential damages resulting from the use or application of this equipment.

The examples and diagrams in this manual are included solely for illustrative purposes. Because of the many variables and requirements associated with any particular installation, Rockwell Automation, Inc. cannot assume responsibility or liability for actual use based on the examples and diagrams.

No patent liability is assumed by Rockwell Automation, Inc. with respect to use of information, circuits, equipment, or software described in this manual.

Reproduction of the contents of this manual, in whole or in part, without written permission of Rockwell Automation, Inc., is prohibited.

Throughout this manual, when necessary, we use notes to make you aware of safety considerations.



**WARNING:** Identifies information about practices or circumstances that can cause an explosion in a hazardous environment, which may lead to personal injury or death, property damage, or economic loss.



**ATTENTION:** Identifies information about practices or circumstances that can lead to personal injury or death, property damage, or economic loss. Attentions help you identify a hazard, avoid a hazard, and recognize the consequence.

---

**IMPORTANT** Identifies information that is critical for successful application and understanding of the product.

---

Labels may also be on or inside the equipment to provide specific precautions.



**SHOCK HAZARD:** Labels may be on or inside the equipment, for example, a drive or motor, to alert people that dangerous voltage may be present.



**BURN HAZARD:** Labels may be on or inside the equipment, for example, a drive or motor, to alert people that surfaces may reach dangerous temperatures.



**ARC FLASH HAZARD:** Labels may be on or inside the equipment, for example, a motor control center, to alert people to potential Arc Flash. Arc Flash will cause severe injury or death. Wear proper Personal Protective Equipment (PPE). Follow ALL Regulatory requirements for safe work practices and for Personal Protective Equipment (PPE).

---

	<b>Preface</b>	
	Summary of Changes .....	5
	Conventions .....	6
	Terminology .....	6
	Additional Resources .....	7
	<b>Chapter 1</b>	
<b>Safety Concept</b>	Certification .....	9
	Important Safety Considerations .....	10
	Safety Category 3 Performance Definition .....	10
	Stop Category Definitions .....	11
	Performance Level and Safety Integrity Level (SIL) CL3 .....	11
	Functional Proof Tests .....	11
	PFD and PFH Definitions .....	12
	PFD and PFH Data .....	12
	Safe State .....	13
	Safety Reaction Time .....	13
	Considerations for Safety Ratings .....	14
	Contact Information if Safety Option Failure Occurs .....	14
	<b>Chapter 2</b>	
<b>Installation and Wiring</b>	Access the Drive Control Pod .....	16
	Set the Safety Enable Jumper .....	20
	Remove Power From the Drive System .....	21
	Verify Zero Voltage on PowerFlex 755 and PowerFlex 753 Drives .....	21
	Verify Zero Voltage on PowerFlex 755T Drive Products .....	22
	Install the Safety Option Module .....	24
	Wire the Safety Option Module .....	25
	Cabling .....	25
	Power Supply Requirements .....	26
	Port Assignment .....	26
	Jumper Settings .....	26
	Verify Operation .....	27
	<b>Chapter 3</b>	
<b>Safe Torque Off Option Module Operation</b>	Operation .....	29
	Stop Category Wiring Examples .....	30

	<b>Appendix A</b>	
<b>Specifications, Certifications, and CE Conformity</b>	Specifications .....	35
	Environmental Specifications.....	36
	Certifications .....	37
	CE Conformity .....	38
	Machinery Directive (2006/42/EC) .....	38
	EMC Directive (2004/108/EC and 2014/30/EU) .....	38

This manual explains how PowerFlex® 750-Series Safe Torque Off option module can be used in Safety Integrity Level (SIL) CL3, Performance Level [PLe], or Category (CAT.) 3 applications. It describes the safety requirements, including PFD and PFH values and application verification information, and provides information on installing, configuring, and troubleshooting the Safe Torque Off option module.

Use this manual if you are responsible for designing, installing, configuring, or troubleshooting safety applications that use the PowerFlex 750-Series Safe Torque Off option module.

The 20-750-S Safe Torque Off option module applies to the following PowerFlex 750-Series drives:

- PowerFlex 755TL low-harmonic, non-regenerative drives
- PowerFlex 755TR regenerative drives
- PowerFlex 755TM drive systems with regenerative bus-supplies and common-bus inverters
- PowerFlex 755 AC drives
- PowerFlex 753 AC drives

Throughout this manual, **PowerFlex 755T drive products** is used to refer to PowerFlex 755TL drives, PowerFlex 755TR drives, and PowerFlex 755TM drive systems.

We recommend that you have a basic understanding of the electrical circuitry and familiarity with these products. You must also be trained and experienced in the creation, operation, and maintenance of safety systems.

## Summary of Changes

This manual contains new and updated information as indicated in the following table.

Topic	Page
Added safety specifications (including PFD and PFH values) for PowerFlex 755T drive products.	12
Updated the Safe State information and added Safety Reaction Time specifications for PowerFlex 755T drive products.	13
Updated Access the Drive Control Pod with references to PowerFlex 755T drive products.	16...19
Updated jumper setting figures and added figure for PowerFlex 755T drive products.	20...21
Added Remove Power From the Drive System.	21
Updated Stop Category Wiring Examples with Guardmaster® safety relays.	30...33
Added Stop Category Wiring Example with POINT Guard I/O™ modules.	34
Updated Environmental Specifications table.	36

## Conventions

In this manual, configuration parameters are listed by number followed by the name in brackets. For example, P24 [OverSpd Response].

## Terminology

This table defines abbreviations used in this manual.

Abbreviation	Full Term	Definition
1oo2	One out of Two	Refers to the behavioral design of a dual-channel safety system.
CAT.	Category	Classification of the safety-related parts of a control system in respect of their resistance to faults and their subsequent behavior in the fault condition, and which is achieved by the structural arrangement of the parts, fault detection, and/or by their reliability (source EN ISO 13849-1).
CL	Claim Limit	The maximum SIL rating that can be claimed for a Safety-Related Electrical Control System subsystem in relation to architectural constraints and systematic safety integrity (source IEC 62061).
EN	European Norm	The official European Standard.
ESD	Emergency Shutdown Systems	A system, usually independent of the main control system, that is designed to safely shut down an operating system.
HFT	Hardware Fault Tolerance	The HFT equals $n$ , where $n+1$ faults could cause the loss of the safety function. An HFT of 1 means that 2 faults are required before safety is lost.
HIM	Human Interface Module	A module used to configure a device.
IEC	International Electrotechnical Commission	The International Electrotechnical Commission (IEC) is the world's leading organization that prepares and publishes International Standards for all electrical, electronic and related technologies.
IGBT	Insulated Gate Bi-polar Transistors	Typical power switch used to control main current.
ISO	International Organization for Standardization	The International Organization for Standardization is an international standard-setting body composed of representatives from various national standards organizations.
PELV	Protective Extra Low Voltage	An electrical system where the voltage cannot exceed ELV under normal conditions, and under single-fault conditions, except earth faults in other circuits.
PFD	Probability of Dangerous Failure on Demand	The average probability of a system to fail to perform its design function on demand.
PFH	Probability of Dangerous Failure per Hour	The probability of a system to have a dangerous failure occur per hour.
PL	Performance Level	EN ISO 13849-1 safety rating
SELV	Safety Extra Low Voltage Circuit	A secondary circuit that is designed and protected so that, under normal and single fault conditions, its voltages do not exceed a safe value.
SIL	Safety Integrity Level	A measure of a products ability to lower the risk that a dangerous failure could occur.
STO	Safe Torque Off	The Safe Torque Off (STO) function is used to prevent unexpected motor rotation in the event of an emergency while the drive remains connected to the power supply. When STO is activated, the torque power cannot reach the drive, thus stopping and preventing any motor shaft rotation.

## Additional Resources

These documents contain additional information concerning related Rockwell Automation products.

Resource	Description
PowerFlex 750-Series Products with TotalFORCE Control Technical Data, publication <a href="#">750-TD100</a>	Provides detailed information on: <ul style="list-style-type: none"> <li>• Drive and bus supply specifications</li> <li>• Option specifications</li> <li>• Fuse and circuit breaker ratings</li> </ul>
PowerFlex 755TM IP00 Open Type Kits Technical Data, publication <a href="#">750-TD101</a>	Provides detailed information on: <ul style="list-style-type: none"> <li>• Kit selection</li> <li>• Kit ratings and specifications</li> <li>• Option specifications</li> </ul>
PowerFlex 750-Series Products with TotalFORCE™ Control Installation Instructions, publication <a href="#">750-IN100</a>	Provides the basic steps to install PowerFlex 755TL drives, PowerFlex 755TR drives, and PowerFlex 755TM bus supplies.
PowerFlex 755TM IP00 Open Type Kits Installation Instructions, publication <a href="#">750-IN101</a>	Provides instructions to install IP00 Open Type kits in user-supplied enclosures.
PowerFlex Drives with TotalFORCE Control Programming Manual, publication <a href="#">750-PM100</a>	Provides detailed information on: <ul style="list-style-type: none"> <li>• I/O, control, and feedback options</li> <li>• Parameters and programming</li> <li>• Faults, alarms, and troubleshooting</li> </ul>
PowerFlex 750-Series AC Drive Installation Instructions, publication <a href="#">750-IN001</a>	Provides information on installing the Safe Torque OFF option module in PowerFlex 750-Series drive.
PowerFlex 750-Series AC Drives Programming Manual, publication <a href="#">750-PM001</a>	Provides information on mounting, installing, and configuring PowerFlex 750-Series drives.
Enhanced PowerFlex 7-Class Human Interface Module (HIM) User Manual, publication <a href="#">20HIM-UM001</a>	Provides information for using the 20-HIM-A6 HIM module to configure PowerFlex 750-Series drives and the Safe Torque OFF option module.
Connected Components Workbench Online Help	Online Help that provides a description of the different elements of the Connected Components Workbench™ software.
PowerFlex Safe Speed Monitor Safety Reference Manual, publication <a href="#">750-RM001</a>	Provides information on installing and configuring the Safe Speed Monitor option module with PowerFlex 750-Series drives.
System Design for Control of Electrical Noise Reference Manual, publication <a href="#">GMC-RM001</a>	Information, examples, and techniques designed to minimize system failures caused by electrical noise.
Safety Guidelines for the Application, Installation and Maintenance of Solid State Control, publication <a href="#">SGI-1.1</a>	Describes important differences between solid-state control and hardwired electromechanical devices.

You can view or download publications at <http://www.rockwellautomation.com/global/literature-library/overview.page>. To order paper copies of technical documentation, contact your local Allen-Bradley distributor or Rockwell Automation sales representative.

**Notes:**



## Safety Concept

This chapter describes the safety performance level concept and how the PowerFlex® 750-Series Safe Torque Off option module meets the requirements for SIL CL3, CAT. 3, or PLe applications.

Topic	Page
Certification	9
Functional Proof Tests	11
PFD and PFH Definitions	12
PFD and PFH Data	12
Safe State	13
Safety Reaction Time	13
Considerations for Safety Ratings	14
Contact Information if Safety Option Failure Occurs	14

### Certification

The PowerFlex 750-Series Safe Torque Off option module is certified for use in safety applications up to and including SIL 3 according to EN 61800-5-2, IEC 61508, and EN 62061, Performance Level PLe and Category 3 according to EN ISO 13849-1. Safety requirements are based on the standards current at the time of certification.

The TÜV Rheinland group has approved the PowerFlex 750-Series Safe Torque Off option module for use in safety-related applications where the de-energized state is considered to be the safe state. All of the examples in this manual are based on achieving de-energization as the safe state for typical Machine Safety and Emergency Shutdown (ESD) systems.

## Important Safety Considerations

The system user is responsible for the following:

- Set-up, safety rating, and validation of any sensors or actuators connected to the system
- Completing a system-level risk assessment and reassessing the system any time a change is made
- Certification of the system to the desired safety performance level
- Project management and proof testing
- Programming the application software and the safety option module configurations in accordance with the information in this manual
- Access control to the system
- Analyzing all configuration settings and choosing the proper setting to achieve the required safety rating

---

**IMPORTANT** When applying Functional Safety, restrict access to qualified, authorized personnel who are trained and experienced.

---



---

**ATTENTION:** When designing your system, consider how personnel exit the machine if the door locks while they are in the machine. Additional safeguarding devices may be required for your specific application.

---

## Safety Category 3 Performance Definition

To achieve Safety Category 3, according to EN ISO 13849-1, design the safety-related parts according to these guidelines:

- The safety-related parts of machine control systems and/or their protective equipment, as well as their components, shall be designed, constructed, selected, assembled, and combined in accordance with relevant standards so that they can withstand expected conditions
- Basic safety principles shall be applied
- A single fault in any of its parts does not lead to a loss of safety function.
- The average diagnostic coverage of the safety-related parts of the control system shall be medium
- The mean-time to dangerous failure of each of the redundant channels shall be high
- Measures against common cause failure shall be applied

---

## Stop Category Definitions

The selection of a stop category for each stop function must be determined by a risk assessment.

- Stop Category 0 is achieved with immediate removal of power to the actuator, resulting in an uncontrolled coast to stop. Safe Torque Off accomplishes a Stop Category 0 stop.
- Stop Category 1 is achieved with power available to the machine actuators to achieve the stop. Power is removed from the actuators when the stop is achieved.

---

**IMPORTANT** When designing the machine application, consider timing and distance for a coast to stop (Stop Category 0 or Safe Torque Off). For more information regarding stop categories and Safe Torque Off, refer to EN 60204-1 and EN 61800-5-2, respectively.

---

## Performance Level and Safety Integrity Level (SIL) CL3

For safety-related control systems, Performance Level (PL), according to EN ISO 13849-1, and SIL levels, according to IEC 61508 and EN 62061, include a rating of the system's ability to perform its safety functions. All of the safety-related components of the control system must be included in both a risk assessment and the determination of the achieved levels.

Refer to the EN ISO 13849-1, IEC 61508, and EN 62061 standards for complete information on requirements for PL and SIL determination.

## Functional Proof Tests

The functional safety standards require that functional proof tests be performed on the equipment used in the system. Proof tests are performed at user-defined intervals and are dependent upon PFD and PFH values.

---

**IMPORTANT** Your specific application determines the time frame for the proof test interval.

Verify operation of safety function after drive installation, modification, or maintenance. Refer to [Verify Operation](#) on [page 27](#) for more information.

---

## PFD and PFH Definitions

Safety-related systems can be classified as operating in either a Low Demand mode, or in a High Demand/Continuous mode.

- Low Demand mode: where the frequency of demands for operation made on a safety-related system is no greater than one per year or no greater than twice the proof-test frequency.
- High Demand/Continuous mode: where the frequency of demands for operation made on a safety-related system is greater than once per year or greater than twice the proof test interval.

The SIL value for a low-demand safety-related system is directly related to order-of-magnitude ranges of its average probability of failure to satisfactorily perform its safety function on demand or, simply, average probability of failure on demand (PFD). The SIL value for a High Demand/continuous mode safety-related system is directly related to the probability of a dangerous failure occurring per hour (PFH).

## PFD and PFH Data

PFD and PFH calculations are based on the equations from Part 6 of IEC 61508.

These tables provide data for a 20-year proof test interval and demonstrates the worst-case effect of various configuration changes on the data.

**Table 1 - PFD and PFH for PowerFlex 753 and PowerFlex 755 Drives**

Attribute	PowerFlex 753 and PowerFlex 755 Drives Frames 1...7	PowerFlex 755 Drives Frame 8	PowerFlex 755 Drives Frame 9	PowerFlex 755 Drives Frame 10
PFD	3.29E-05	1.73E-04	2.65E-04	3.56E-04
PFH (1/hour)	3.75E-10	1.99E-09	3.04E-09	4.09E-09
SIL CL	3	3	3	3
PL	e	e	e	e
Category	3	3	3	3
HFT	1 (1002)	1 (1002)	1 (1002)	1 (1002)
Mission time	20 years	20 years	20 years	20 years

**Table 2 - PFD and PFH for PowerFlex 755T Drive Products**

Attribute	Drive Frame 8	Drive Frame 9	Drive Frame 10	Drive Frame 11	Drive Frame 12
PFD	2.48E-04	2.74E-04	3.00E-04	3.26E-04	3.52E-04
PFH (1/hour)	2.86E-09	3.15E-09	3.45E-09	3.75E-09	4.05E-09
SIL CL	3	3	3	3	3
PL	e	e	e	e	e
Category	3	3	3	3	3
HFT	1 (1002)	1 (1002)	1 (1002)	1 (1002)	1 (1002)
Mission time	20 years	20 years	20 years	20 years	20 years

## Safe State

The safe state encompasses all operation that occurs outside of the other monitoring and stopping behavior defined as part of the Safe Torque Off option module.

If a Safe State fault is detected, the safety option module transitions to the safe state. This includes faults related to the integrity of hardware or firmware. The drive safe state is defined as preventing force-producing power from being provided to the motor. For more information on the safe state, see IEC 61800-5-2.

---

**IMPORTANT** The drive is in the safe state if the safety function is installed and the drive status is 'Not Enabled'. Drive 'Ready' is NOT a safe state even if there is no motion.

---



**ATTENTION:** In circumstances where external influences (for example, falling of suspended loads) are present, additional measures (for example, mechanical brakes) can be necessary to prevent a hazard.

---

## Safety Reaction Time

The safety reaction time is the length of time from a safety-related event as input to the system until the system is in the safe state.

The safety reaction time from an input signal condition that triggers a safe stop, to the initiation of the configured Stop Type, is shown in [Table 3](#).

**Table 3 - Safety Reaction Time**

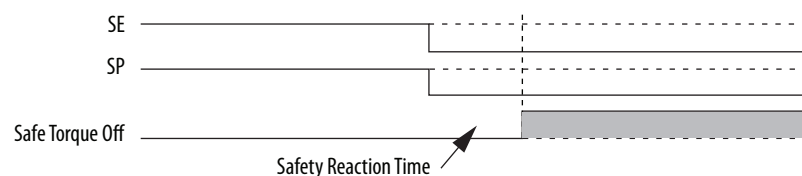
Drive Family	Value, max
PowerFlex 753 drives Frames 1...7	10 ms
PowerFlex 755 drives Frames 1...10	10 ms
PowerFlex 755T drive products Frames 8...12	10 ms

---

**IMPORTANT** An input signal condition that is present for less than the reaction time can not result in the safety function being performed. Repeated requests of the safety function for less than the reaction time can result in a spurious detection of a fault.

---

**Figure 1 - Safety Reaction Timing Diagram**



## Considerations for Safety Ratings

The achievable safety rating of an application using the safety option module installed in PowerFlex 750-Series drives is dependent upon many factors, drive options, and the type of motor.

For applications that rely on the immediate removal of power to the actuator, resulting in an uncontrolled coast to stop, a safety rating up to and including SIL CL3, PLe, and Category 3 can be achieved.

## Contact Information if Safety Option Failure Occurs

If you experience a failure with any safety-certified device, contact your local Rockwell Automation distributor. With this contact, you can do the following:

- Return the device to Rockwell Automation so the failure is appropriately logged for the catalog number affected and a record is made of the failure.
- Request a failure analysis (if necessary) to determine the probable cause of the failure.

## Installation and Wiring

This chapter provides installation, jumper settings, and wiring for the PowerFlex® 750-Series Safe Torque Off option module.

Topic	Page
Access the Drive Control Pod	16
Set the Safety Enable Jumper	20
Remove Power From the Drive System	21
Wire the Safety Option Module	25
Verify Operation	27

Installation must be in accordance with the following steps and must be carried out by competent personnel. The Safe Torque Off option module is intended to be part of the safety related control system. Before installation, perform a risk assessment that compares the Safe Torque Off option module specifications and all foreseeable operational and environmental characteristics of the control system.

A safety analysis of the machine section controlled by the drive is required to determine how often to test the safety function for proper operation during the life of the machine.



**ATTENTION:** The following information is merely a guide for proper installation. Rockwell Automation, Inc. cannot assume responsibility for the compliance or the noncompliance to any code, national, local or otherwise for the proper installation of this equipment. A hazard of personal injury and/or equipment damage exists if codes are ignored during installation.

**IMPORTANT** During installation and maintenance, check your drive firmware release notes for known anomalies and verify that there are no safety-related anomalies.

## Access the Drive Control Pod

Follow these steps to remove the drive covers and access the enable jumpers.

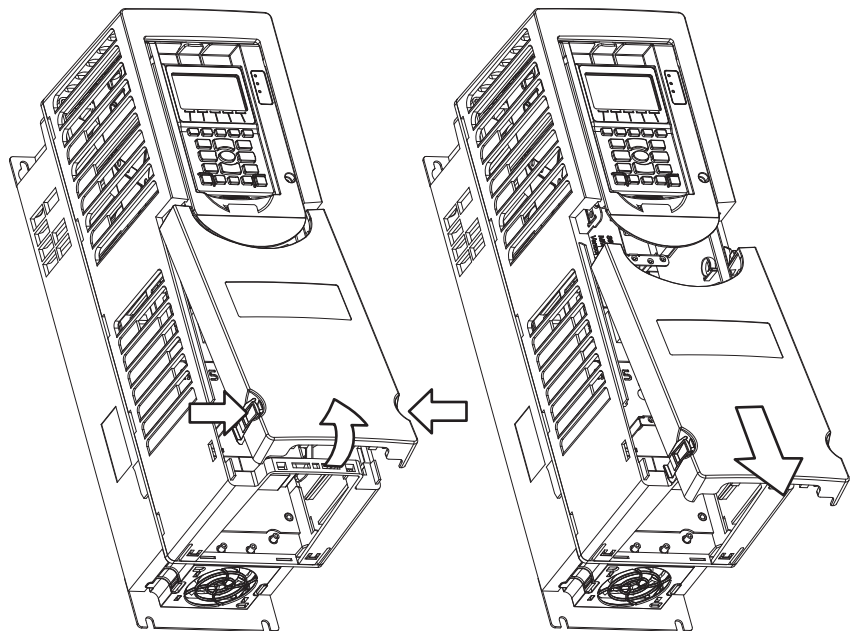


### ATTENTION:

- Electrical Shock Hazard. Verify that all sources of AC and DC power are de-energized and locked out or tagged out in accordance with the requirements of ANSI/NFPA 70E, Part II.
- To avoid an electric shock hazard, verify that the voltage on the bus capacitors has discharged before performing any work on the drive. Measure the DC bus voltage at the +DC and -DC terminals or test points (refer to your drive's user manual for locations). The voltage must be zero.
- In Safe Torque Off mode, hazardous voltages may still be present at the motor. To avoid an electric shock hazard, disconnect power to the motor and verify that the voltage is zero before performing any work on the motor.

1. Remove drive cover.

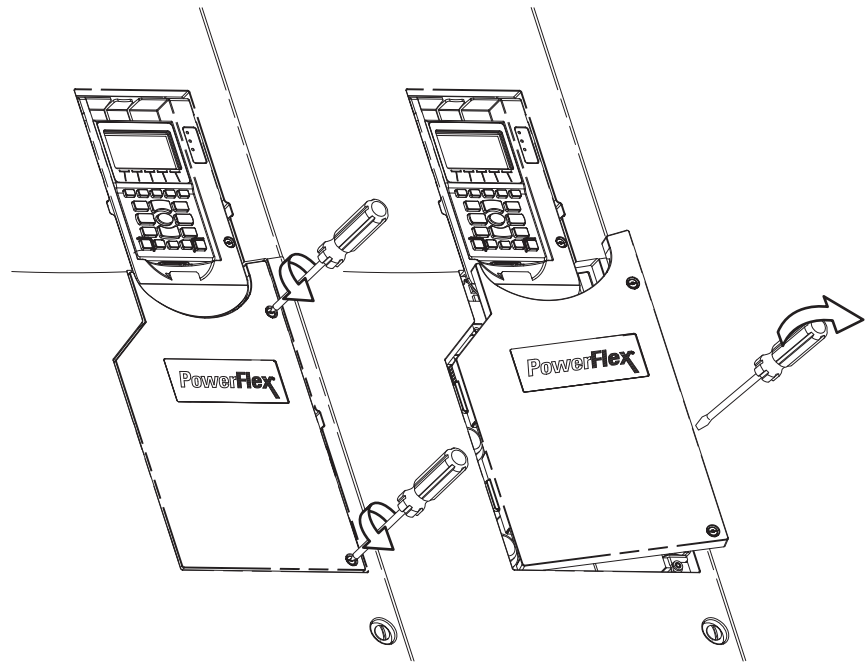
PowerFlex 755 and PowerFlex 753 Drives, Frames 1...5



- a. Squeeze locking tabs and pull out bottom of cover.
- b. Pull cover down and away from the chassis



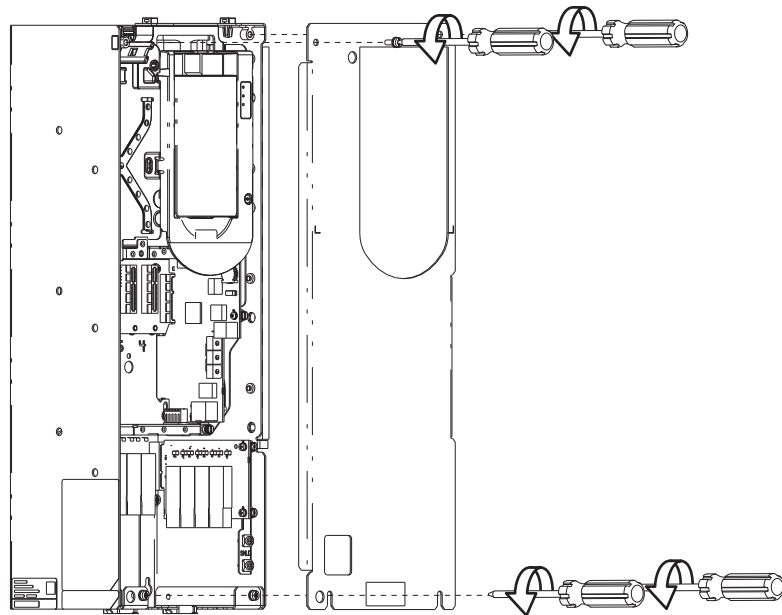
PowerFlex 755 and PowerFlex 753 Drives, Frames 6...7



- a. Loosen door screws.
- b. Gently pry the door open to remove.

PowerFlex 755 and PowerFlex 753 Drives, Frames 8...10  
PowerFlex 755T Drive Products, Frames 8...12

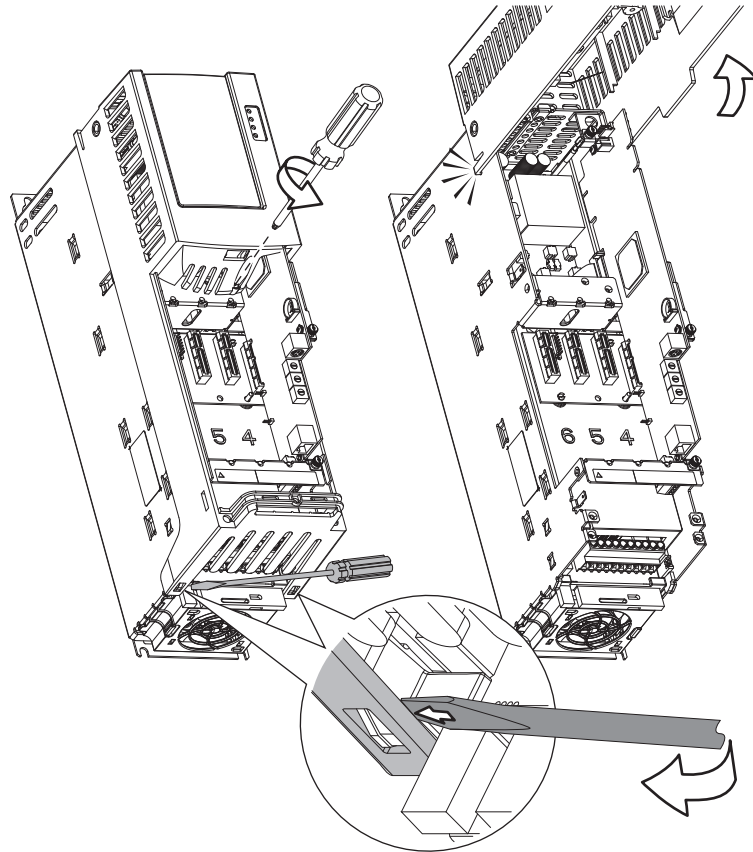
PowerFlex 750-Series Drives,  
Frames 8...10 are shown



- a. Remove top screws.
- b. Loosen bottom screws.
- c. Remove the right front cover.

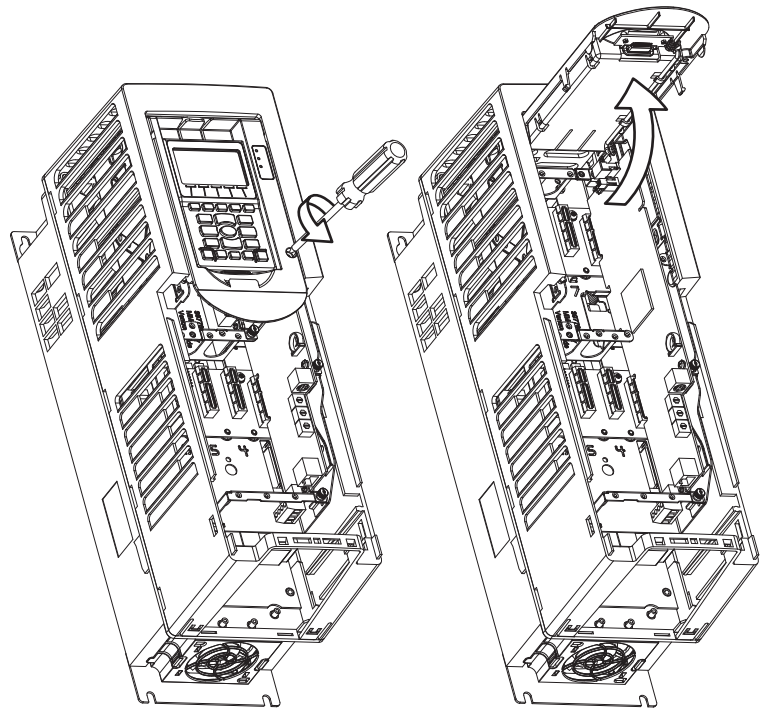
2. This step applies to PowerFlex 755 and PowerFlex 753 drives.
  - Lift the chassis cover (Frame 1 drives).
  - Lift the Human Interface Module (HIM) cradle (Frames 2...7 drives).

PowerFlex 755 and PowerFlex 753 Drives, Frame 1



- a. Loosen the retention screw.
- b. Use a screwdriver to release the chassis cover locking tabs.
- c. Lift the chassis until the latch engages.

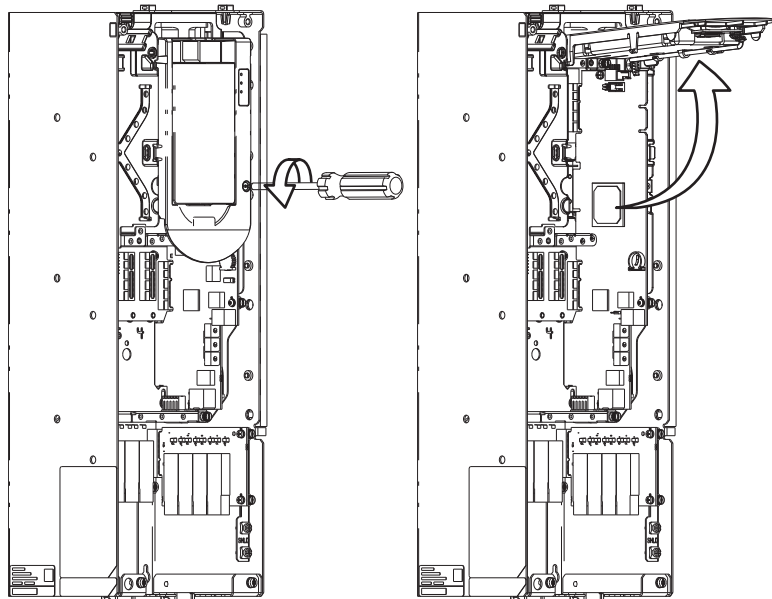
PowerFlex 755 and PowerFlex 753 Drives, Frames 2...7



- a. Loosen the retention screw.
- b. Lift the cradle until the latch engages.

PowerFlex 755 and PowerFlex 753 Drives, Frames 8...10 and  
PowerFlex 755T Drive Products, Frames 8...12

PowerFlex 755 and PowerFlex 753 Drives,  
Frames 8 . . . 10 are shown



- a. Loosen the retention screw.
- b. Lift the cradle until the latch engages.

## Set the Safety Enable Jumper

The PowerFlex 750-Series drives ship with the safety-enable (SAFETY) jumper installed. The jumper, located on the main control board, must be removed when using the Safe Torque Off option module.

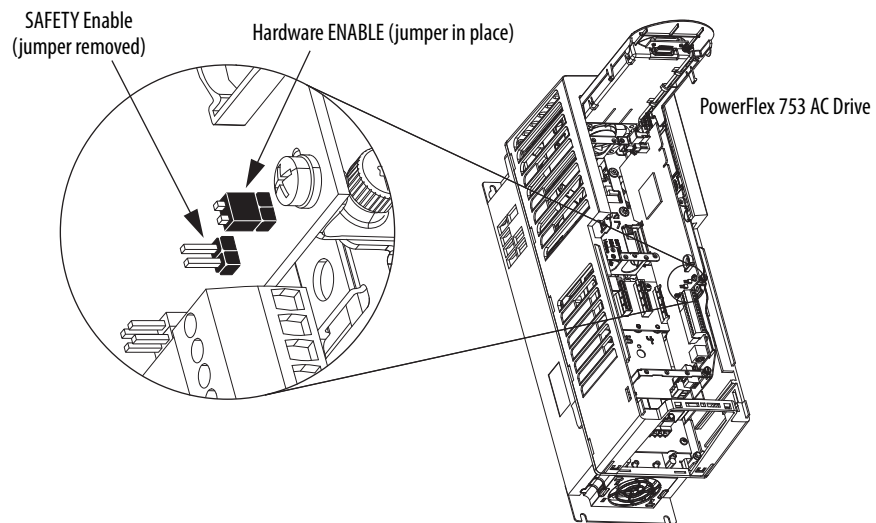
---

**IMPORTANT** Failure to remove the SAFETY jumper causes the drive to fault when a start command is issued.

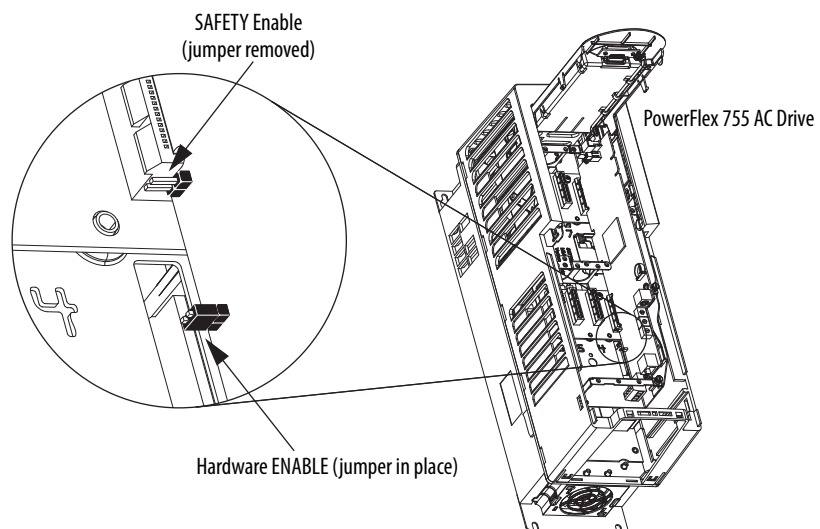
---

The Di0 digital output on the main control board can be designated as a Hardware Enable function by removing the hardware ENABLE jumper. If this jumper is removed, the drive will not run unless the Di0 digital input is activated. The Di0 input is not related to the operation of the safety option module. If you are not using the Di0 input as Hardware Enable, do not remove the hardware ENABLE jumper.

**Figure 2 - PowerFlex 753 Drive Jumper Locations**

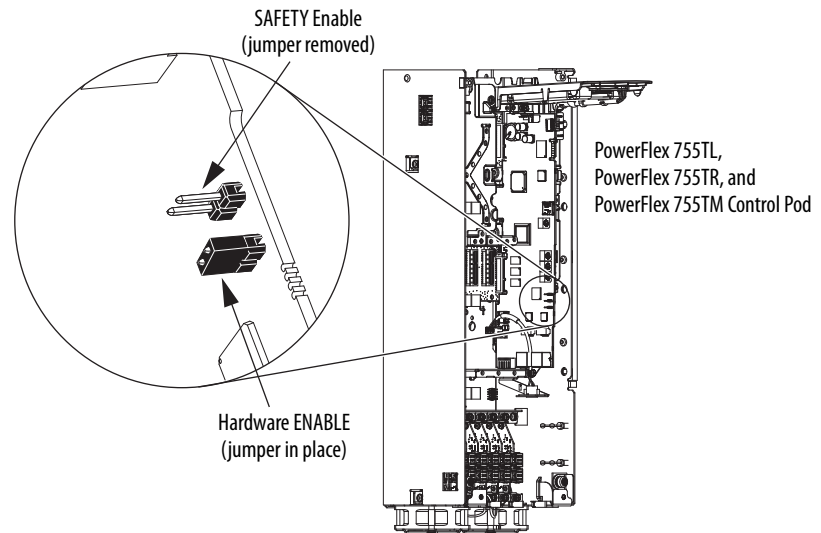


**Figure 3 - PowerFlex 755 Drive Jumper Locations (frames 1...7 only)**



PowerFlex 755 drives (frame 8, 9, and 10) do not have a safety enable jumper.

Figure 4 - PowerFlex 755T Drive Products Jumper Locations



## Remove Power From the Drive System

Before installation, remove power from the drive system and verify that the voltage on the bus capacitors has discharged before performing any work on the drive. The voltage at all test points must be 0 volts.



**ATTENTION:** To avoid an electric shock hazard when servicing the drive, a means for Lockout/Tagout of the external, single-phase 120/240V power source and, if present, external 120V uninterruptible power supply source, must be provided.

1. Turn off and lockout all input power, including any external power sources (such as an Active Front End or other DC power source).
2. If present, turn off and lockout any external, single-phase 120/240V power source.



**ATTENTION:** Hazard of equipment damage exists if a safety option module is installed or removed while the drive is powered. To avoid damaging the drive, verify that the voltage on the bus capacitors has discharged before performing any work on the drive.

## Verify Zero Voltage on PowerFlex 755 and PowerFlex 753 Drives

For PowerFlex 755 and PowerFlex 753 Drives (Frames 1...7), measure the DC-bus voltage at the Power Terminal Block by measuring between the:

- +DC and -DC terminals
- +DC terminal and the chassis
- -DC terminal and the chassis.

For PowerFlex 755 and PowerFlex 753 Drives (Frames 8...10), measure the DC bus voltage at the DC+ and DC- TESTPOINT sockets on the front of the power module.

### Verify Zero Voltage on PowerFlex 755T Drive Products

1. For low-harmonic/regenerative drives and common bus supplies, complete steps a...d.
  - a. On the power input bay, turn the disconnect switch to the Off position.
  - b. Wait 15 minutes and open the enclosure door.
  - c. Close and lock the hasp on the circuit breaker.
  - d. Lock the fused disconnect switch.
2. For common-bus inverters, complete steps a...e.
  - a. Turn the disconnect switch to the “Off” position.
  - b. Wait 15 minutes and open the enclosure door.
  - c. Close and lock the hasp on the molded case switch.
  - d. Lock the fused disconnect switch.
  - e. If a control bay is used, turn the selector switch to the Off position and lock the switch.



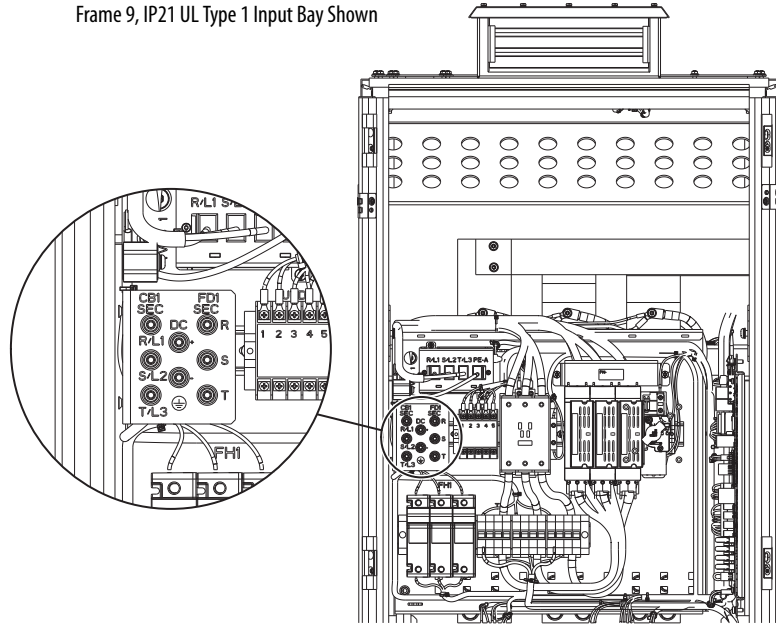
**ATTENTION:** To avoid an electric shock hazard, verify that there is no AC input and DC bus voltage before servicing by taking these measurements:

- Verify that there is no AC input voltage present using the R/L1, S/L2, and T/L3 testpoint sockets in the input bay by measuring L to L and L to GND.
- Verify that there is no AC input voltage present using the R, S, and T testpoint sockets in the input bay by measuring L to L and L to GND.
- Verify that there is no DC bus voltage present using the +DC to -DC testpoints in the input bay by measuring +DC to -DC, +DC to GND, and -DC to GND.

3. For low-harmonic/regenerative drives and common-bus supplies, measure the AC input and DC-bus voltage at the following testpoint sockets in the power bay:
  - Measure L to L and L to chassis GND using the circuit breaker output (CB1) testpoints R/L1, S/L2, and T/L3.
  - Measure L to L and L to chassis GND using the fused disconnect output (FD1) testpoints R, S, and T.
  - Measure +DC to -DC, +DC to chassis GND, and -DC to chassis GND using the DC bus testpoints +DC and -DC.

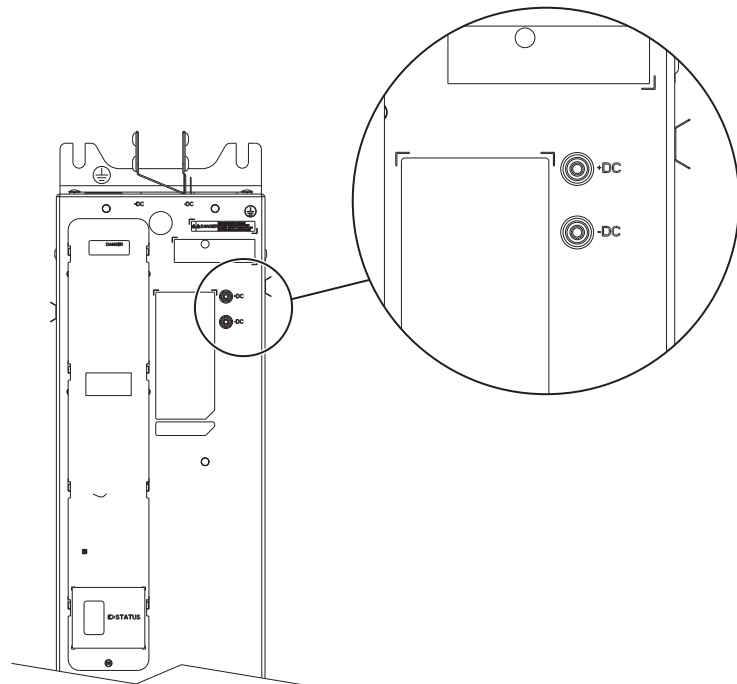
The voltage at all test points must be 0 volts.

Frame 9, IP21 UL Type 1 Input Bay Shown



**ATTENTION:** To avoid an electric shock hazard, verify that the voltage on the bus capacitors has discharged completely before servicing. Verify that there is no DC bus voltage present using the +DC to -DC testpoints on all power modules by measuring +DC to -DC, +DC to GND, and -DC to GND.

4. For common-bus inverters, measure the DC-bus voltage of all power modules and verify that there is no voltage present on the bus capacitors. Measure +DC to -DC, +DC to chassis GND, and -DC to chassis GND using the DC bus testpoints +DC and -DC.



5. Measure the 240V AC control voltage at the appropriate terminals:
  - For low-harmonic/regenerative drives and common-bus supplies, in the power input bay, measure terminals L and N on terminal block TB2.
  - For control bays, measure terminal L at FH2-2 and terminal N at terminal block TB4.

## Install the Safety Option Module

To install the Safe Torque Off option module:

1. Firmly press the module edge connector into the desired port.

---

**IMPORTANT** The Safe Torque Off option module can be installed in any drive port. However, when used in an integrated motion application, the module must be installed in port 6.

---

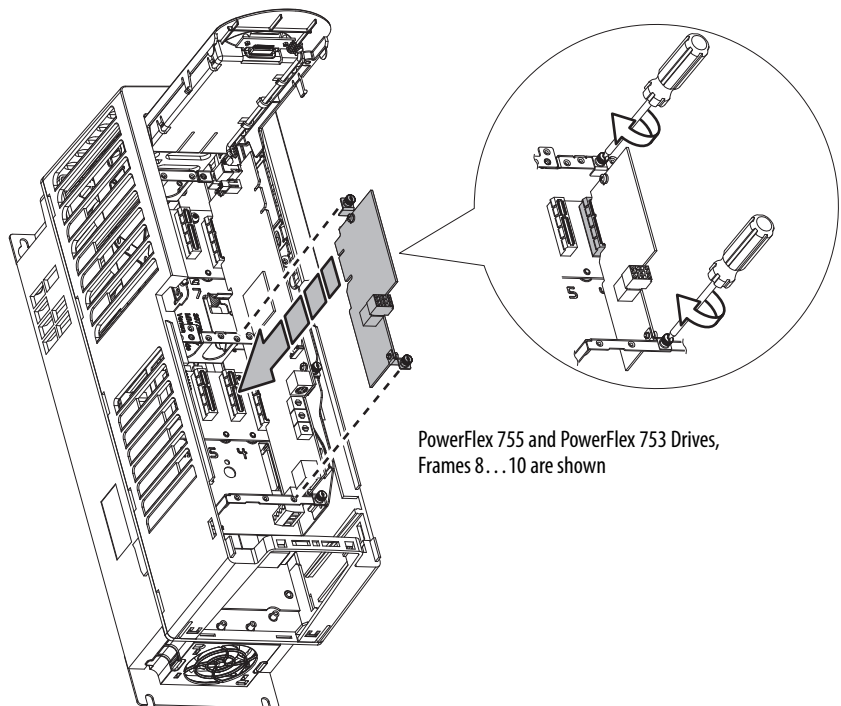
2. Tighten the top and bottom retaining screws.
  - Recommended torque = 0.45 N•m (4.0 lb•in)
  - Recommended screwdriver = T15 Hexalobular




---

**IMPORTANT** Do not over-tighten retaining screws.

---





## Wire the Safety Option Module

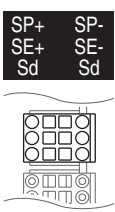
Observe these wiring guidelines when installing the safety option module:

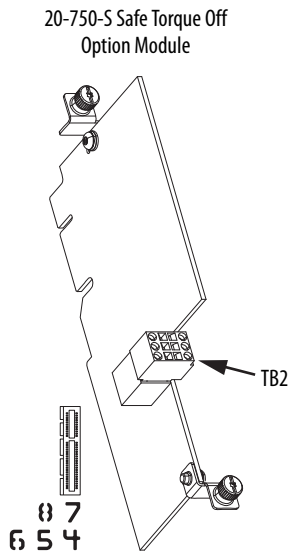
- Use copper wire with an insulation rating of 600V or greater is recommended.
- Separate control wires from power wires by at least 0.3 m (1 ft).

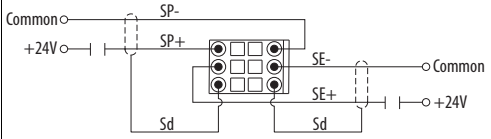
**Table 4 - Safety Option Module Terminal Block Specifications**

Wire Size Range		Wire Type	Strip Length
Maximum	Minimum		
0.8 mm <sup>2</sup> (18 AWG)	0.3 mm <sup>2</sup> (28 AWG)	Multi-conductor shielded cable	10 mm (0.39 in.)

**Table 5 - TB2 Terminal Designations**

	Terminal	Name	Description
	SP+	+24 Volt Safety Power	User-supplied power: 24 volt ±10%
	SP-	Safety Power Common	45 mA typical
	SE+	+24 Volt Safety Enable	User-supplied power: 24 volt ±10%
	SE-	Safety Enable Common	25 mA typical
	Sd	Shield	Terminating point for wiring shields when an EMC plate or conduit box is not installed.
	Sd	Shield	



Safety Input	Connection Example
Power Supply	

## Cabling

Safety input wiring must be protected against external damage by cable ducting, conduit, armored cable or other means.

Shielded cable is required. For proper shield termination, follow the installation requirements related to EN 61800-3 and the EMC Directive as described in these publications:

- PowerFlex 750-Series AC Drive Installation Instructions, publication [750-IN001](#)
- PowerFlex 750-Series Products with TotalFORCE™ Control Installation Instructions, publication [750-IN100](#)

## Power Supply Requirements

The external power supply must conform to the Directive 2014/35/EU Low Voltage, by applying the requirements of EN61131-2 Programmable Controllers, Part 2 - Equipment Requirements and Tests and one of the following:

- EN60950 - SELV (Safety Extra Low Voltage)
- EN60204 - PELV (Protective Extra Low Voltage)
- IEC 60536 Safety Class III (SELV or PELV)
- UL 508 Limited Voltage Circuit
- 24V DC  $\pm 10\%$  must be supplied by a power supply that complies with IEC 60204 and IEC 61558-1.

For specific power supply recommendations, refer to the PowerFlex 750-Series Products with TotalFORCE Control Installation Instructions, publication [750-IN100](#).

For planning information, refer to the guidelines in Industrial Automation Wiring and Grounding Guidelines, publication [1770-4.1](#).

## Port Assignment

When used in an integrated motion application, the safety option module must be installed in port 6.

Only one safety option module can be installed at a time. Multiple option modules or duplicate option module installations are not supported.

## Jumper Settings

Make sure that the hardware enable (ENABLE) jumper on the main control board is installed. Refer to [page 20](#) for location. If not installed, the drive faults upon power up.

Make sure that the safety enable (SAFETY) jumper on the main control board is removed. Refer to [page 20](#) for the location.

## Verify Operation

Test the safety function for proper operation after initial installation of the safety option module. Retest the safety function at the intervals determined by the safety analysis described on [page 15](#).

Verify that both safety channels are functioning according to [Table 6](#).

**Table 6 - Channel Operation and Verification**

Safety Function Status	Drive Not Enabled	Drive Not Enabled	Drive Not Enabled	Drive Enabled (Ready)
<b>Safety Channel Operation</b>				
<b>Safety Option Module</b> Terminals SP+ & SP- (safety power)	No Power Applied	Power Applied	No Power Applied	Power Applied
<b>Safety Option Module</b> Terminals SE+ & SE- (safety enable)	No Power Applied	No Power Applied	Power Applied	Power Applied

**IMPORTANT** If an external fault is present on the wiring or circuitry controlling the Safety Enable or Safety Power inputs for a period of time, the safety option module does not detect this condition. When the external fault condition is removed the safety option module will allow an enable condition.

To achieve maximum safety rating, both safety inputs SP and SE must be activated by appropriate dual-channel equipment. The repeated activation of the safety function by only one input at a time can result in a spurious detection of a fault.

**TIP** There is no safe-status output provided on the safety option module.

**Notes:**

## Safe Torque Off Option Module Operation

This chapter provides operation and Stop Category example wiring diagrams for the PowerFlex® 750-Series Safe Torque Off option module.

Topic	Page
Operation	29
Stop Category Wiring Examples	30

### Operation

The PowerFlex 750-Series Safe Torque Off option module (see [Figure 5](#)) disables the drive's output IGBT's by disconnecting power to the gate control driver IC or disabling the output of the gate-control driver IC. This helps prevent the drive's output power devices from switching in the pattern necessary to generate AC power to the motor.

The safety option module can be used in combination with other safety devices to satisfy the requirements of IEC 61508, IEC 61800-5-2 SIL 3, EN ISO 13849-1 PLe, and Category 3 for Safe Torque Off (STO).

---

**IMPORTANT** The safety option module is suitable for performing mechanical work on the drive system or affected area of a machine only. It does not provide electrical safety.

The safety option module should not be used as a control for starting and/or stopping the drive.

---



---

**IMPORTANT** The safety option module does not eliminate dangerous voltages at the drive output. Input power to the drive must be turned off and safety procedures followed before performing any electrical work on the drive or motor. Refer to [Remove Power From the Drive System](#) on [page 21](#) for more information.

---




---

**ATTENTION:** In the event of the failure of two output IGBTs in the drive, when the safety option module has controlled the drive outputs to the OFF state, the drive can provide energy for up to 180° of rotation in a 2-pole motor before torque production in the motor ceases.

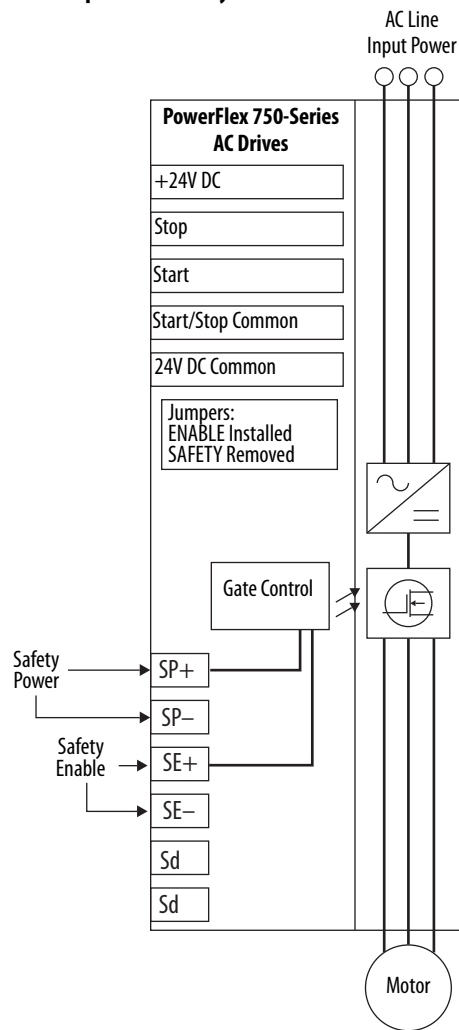
---

Under normal operation, 24V DC is applied to both the Safety Power and Safety Enable inputs of the safety option module. If the Safety Enable or Safety Power is de-energized, the outputs of the gate-control driver IC are disabled and IGBT firing is disabled. Parameter 933 [Start Inhibits] indicates that IGBTs are inhibited and the HIM indicates that the drive is not enabled.



**ATTENTION:** By itself, the safety option module initiates a coast-to-stop action. Additional protective measures must be applied when an application requires a different stopping action.

Figure 5 - Drive Safe Torque Off Circuitry

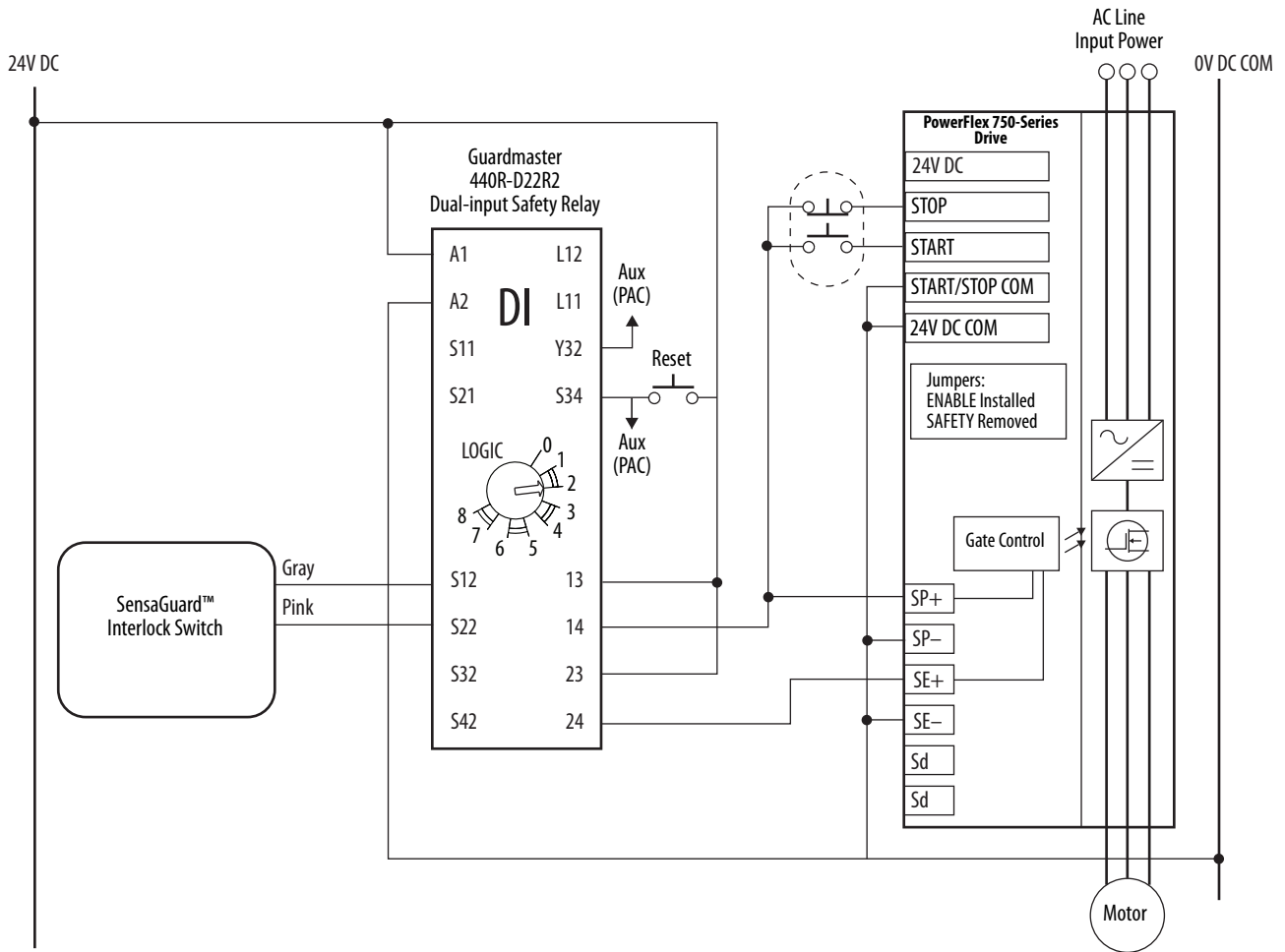


## Stop Category Wiring Examples

The following diagrams illustrate Stop Category 0 and Stop Category 1 dual-channel wiring examples for PowerFlex 750-Series drives with Guardmaster® safety relays. Examples include the following drive families:

- PowerFlex 753 and PowerFlex 755 Drives, Frames 1...10
- PowerFlex 755T Drive Products, Frames 8...12

**Figure 6 - Stop Category 0**



**Table 7 - Guardmaster DI Example Summary**

Attribute	Description
Circuit status	Circuit is shown with guard door closed and system ready for normal drive operation.
Operating principle	This is a dual-channel system with monitoring of the Safe Torque Off circuit and drive. Opening the guard door switches the input circuits (S12 and S22) to the Guardmaster monitoring safety relay. The output circuits (13, 14 and 23, 24) cause the safety option module and drive Enable circuit to trip and the motor coast to stop. To restart the drive, the Guardmaster safety relay must first be reset followed by a valid start command to the drive.
Fault detection	A single fault detected on the Guardmaster safety input circuits results in the lock-out of the system at the next operation and does not cause loss of the safety function.

Figure 7 - Stop Category 0

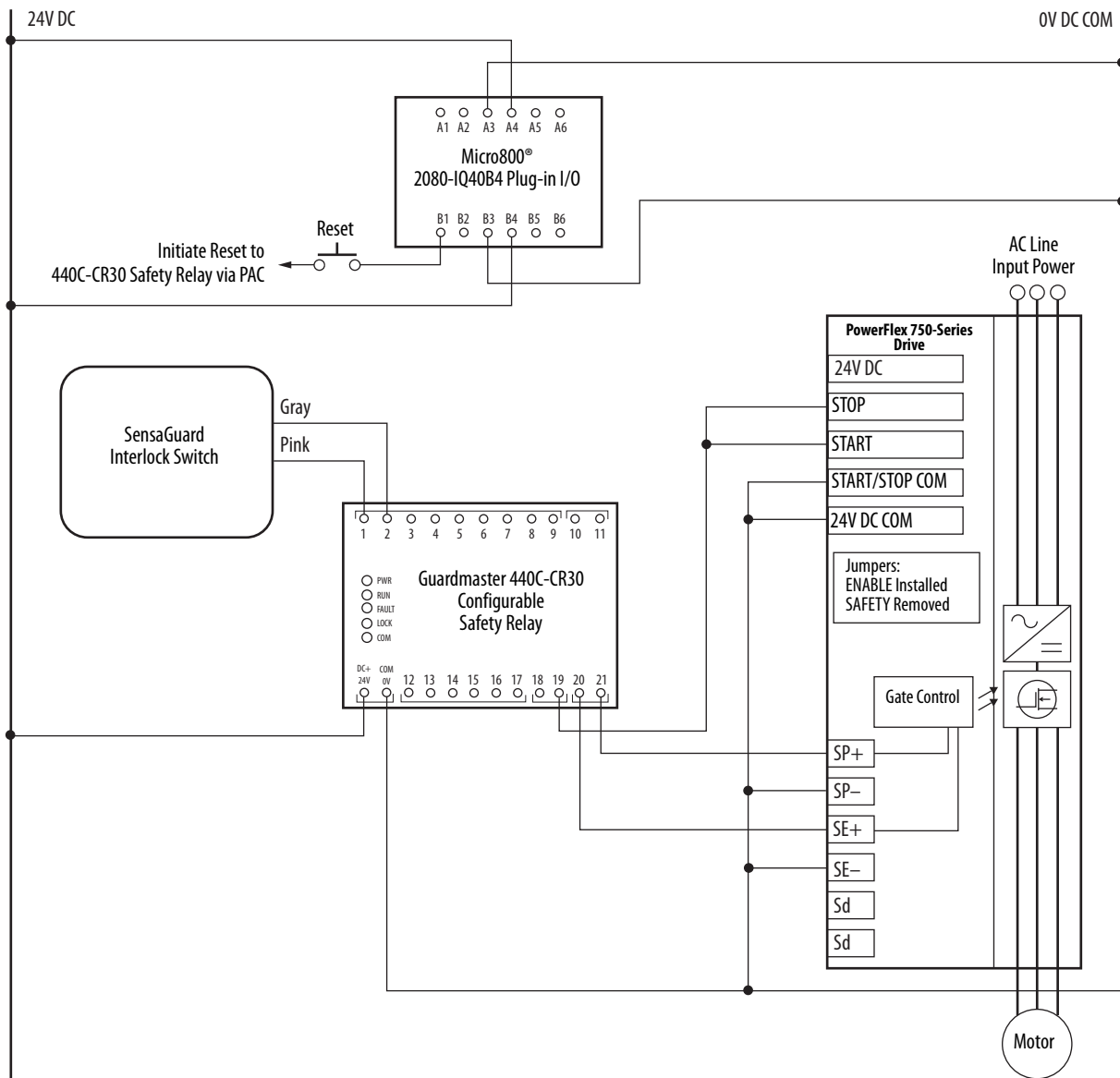
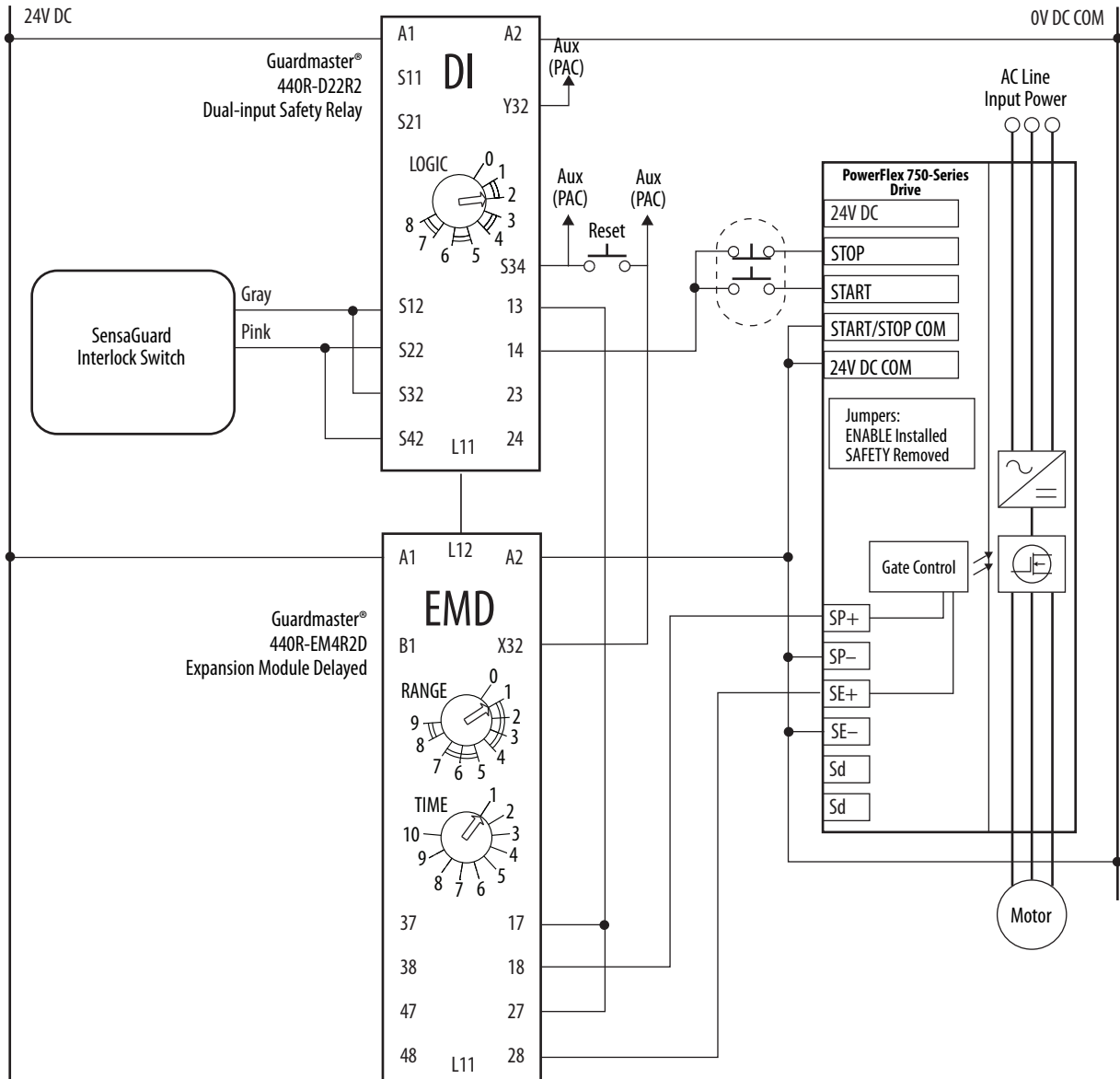


Table 8 - Guardmaster Configurable Relay Example Summary

Attribute	Description
Circuit status	Circuit is shown with guard door closed and system ready for normal drive operation.
Operating principle	This is a dual-channel system with monitoring of the Safe Torque Off circuit and drive. Monitoring is software configurable by using Connected Components Workbench software. Opening the guard door switches the input circuits (1 and 2) to the Guardmaster monitoring safety relay. The output circuits (19, 20, and 21) cause the drive Enable circuit to trip and the motor coast to stop. To restart the drive, the Guardmaster safety relay must first be reset followed by a valid start command to the drive.
Application Considerations	When the hazard analysis for the overall machine determines the need for external mechanical brakes or other stopping means, the external means shall be activated after the removal of power for Stop Category 0. If the safety option module sticks ON, the motor stops on command due to the enable input. The system cannot be reset when this fault condition exists.



**Figure 8 - Stop Category 1**



**Table 9 - Guardmaster DI and EMD Example Summary**

Attribute	Description
Circuit status	Circuit is shown with guard door closed and system ready for normal drive operation.
Operating principle	This is a dual-channel system with monitoring of the Safe Torque Off circuit and drive. Opening the guard door switches the input circuits (S12, S22 and S32, S42) to the Guardmaster monitoring safety relay. The output circuits (13, 14) issue a Stop command to the drive and cause a controlled deceleration. After the programmed delay, the timed output circuits (17, 18 and 27, 28) causes the Safe Torque Off option module and the drive Enable circuit to trip. If the motor is rotating when the trip occurs, it will coast to stop. To restart the drive, the Guardmaster safety relay must first be reset followed by a valid start command to the drive.
Fault detection	A single fault detected on the Guardmaster safety input circuits results in the lock-out of the system at the next operation and does not cause loss of the safety function. If the safety option module sticks ON, the motor stops on command due to the enable input. The system cannot be reset when this fault condition exists.

Figure 9 - Stop Category 0

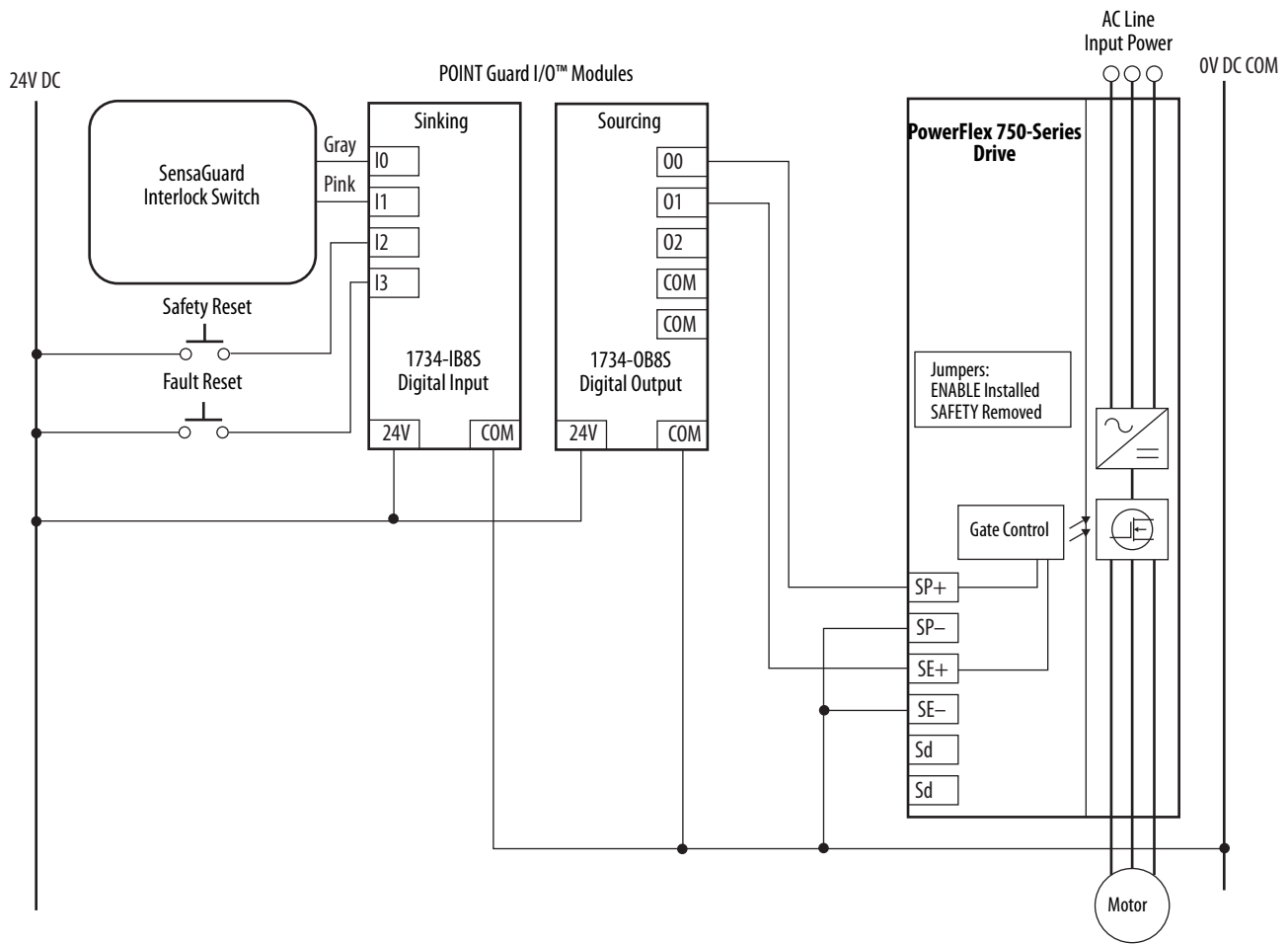


Table 10 - POINT Guard I/O Example Summary

Attribute	Description
Circuit status	Circuit is shown with guard door closed and system ready for normal drive operation.
Operating principle	When a partial-access guard door is opened, the safety system initiates and maintains a stop command to stop hazardous motion before a person can reach the hazardous area. The safety system cannot be reset, and hazardous motion cannot be restarted while the guard door is open. Once the guard door is closed and the stop command is reset, a valid start command is required before hazardous motion can resume.
Fault detection	The GuardLogix controller-logic monitors the system for valid status and faults. When it receives a safety demand on its inputs or an invalid status or fault is detected, the GuardLogix controller-logic deactivates its safety outputs and sends a safety stop command. The PowerFlex drive monitors its internal safety circuits for valid status and faults. When the GuardLogix controller de-energizes the drive Safe Torque Off (STO) inputs, or an invalid state or fault is detected, the drive's STO feature forces the drive output power transistors to a disabled state. The hazardous motion that is controlled by the drive coasts or ramps to a stop. This feature does not provide electrical power isolation.

## Specifications, Certifications, and CE Conformity

This appendix provides general specifications for the PowerFlex® 750-Series Safe Torque Off option module.

Topic	Page
Specifications	35
Certifications	37
CE Conformity	38

### Specifications

These specifications apply to the Safe Torque Off option module. For additional specifications, refer to the following publications:

- PowerFlex 750-Series AC Drives Technical Data, publication [750-TD001](#)
- PowerFlex 750-Series Products with TotalFORCE™ Control Technical Data, publication [750-TD100](#)

**Table 11 - General Specifications**

Attribute	Value
Standards	EN 60204-1, IEC 61508, EN 61800-3, EN 61800-5-1, EN 61800-5-2, EN 62061, EN ISO 13849-1
Safety category	Cat. 3 and PL e per EN ISO 13849-1; SIL CL3 per IEC 61508 and EN 62061
Power supply (user I/O)	24V DC ±10%, 0.8...1.1 x rated voltage <sup>(2)</sup> PELV or SELV
Power consumption	4.4 watts
Safety enable SE+, SE-	24V DC, 25 mA
Safety power SP+, SP-	24V DC, 45 mA
Input ON Voltage, min	24V DC ±10%, 21.6...26.4V DC
Input OFF Voltage, max	5V
Input OFF Current, max	2.5 mA @ 5V DC
Conductor type	Multi-conductor shielded cable
Conductor size <sup>(1)</sup>	0.3...0.8 mm <sup>2</sup> (28...18 AWG)
Strip length	10 mm (0.39 in.)

(1) Refer to Industrial Automation Wiring and Grounding Guidelines, publication 1770-4.1.

(2) Safety outputs need additional fuse for reverse voltage protection of the control circuit. Install a 6 A slow-blow or 10 A fast-acting fuse.

## Environmental Specifications

The installation must comply with all environmental, pollution degree, and drive enclosure rating specifications required for the operating environment.

Category	Specification
Ambient temperature	For detailed information on environmental, pollution degree, and drive enclosure rating specifications, see the technical data publication for your drive. <ul style="list-style-type: none"> <li>• PowerFlex 750-Series AC Drives Technical Data, publication <a href="#">750-TD001</a></li> <li>• PowerFlex 750-Series Products with TotalFORCE Control Technical Data, publication <a href="#">750-TD100</a></li> <li>• PowerFlex 755TM IP00 Open Type Kits Technical Data, publication <a href="#">750-TD101</a></li> </ul>
Storage temperature	
Shock	
Operating	
Packaged for shipment	
Vibration	
Operating	
Packaged for shipment	
Sinusoidal loose load	
Random secured	
Surrounding environment	



**ATTENTION:** Failure to maintain the specified ambient temperature can result in a failure of the safety function.

### IMPORTANT

Products with a safety function installed must be protected against conductive contamination by one of the following methods:

- Select a product with an enclosure type of at least IP54, NEMA/UL Type 12
- Provide an environmentally controlled location for the product that does not contain conductive contamination

## Certifications

See the Product Certification link at <http://www.rockwellautomation.com/global/certification/overview.page> for Declarations of Conformity, Certificates, and other certifications details.

Certification <sup>(1)</sup>	Value
c-UL-us <sup>(2)</sup>	UL Listed, certified for US and Canada.
CE	European Union 2004/108/EC and 2014/30/EU EMC Directive, compliant with: EN 61800-3; PowerFlex 750-Series AC Drive, Emissions and Immunity EN 62061; Safety Function, Immunity European Union 2006/42/EC Machinery Directive: EN ISO 13849-1; Safety Function EN ISO 13849-2; Safety Function EN 60204-1; Safety Function EN 62061; Safety Function EN 61800-5-2; Safety Function
RCM	Australian Radiocommunications Act, compliant with: EN 61800-3; categories C2 and C3
TÜV	Certified by TÜV Rheinland for Functional Safety: up to SIL CL3, according to EN 61800-5-2, IEC 61508, and EN 62061; up to Performance Level PLe and Category 3, according to EN ISO 13849-1; when used as described in this PowerFlex 750-Series Safe Torque Off User Manual, publication <a href="#">750-UM002</a> .

(1) When product is marked, refer to <http://www.rockwellautomation.com/global/certification/overview.page> for Declarations of Conformity Certificates.

(2) Underwriters Laboratories Inc. has not evaluated the Safe Torque Off, or Safe Speed Monitor option modules for functional safety.

## CE Conformity

CE Declarations of Conformity are available online at:

<http://www.rockwellautomation.com/global/certification/ce.page?>

The 20-750-S Safe Torque Off option module is in conformity with the essential requirements of the 2006/42/EC Machinery Directive and the 2004/108/EC EMC Directive when installed and maintained in accordance with the instructions contained in this document. The following standards have been applied to demonstrate conformity:

### Machinery Directive (2006/42/EC)

- EN ISO 13849-1 Safety of machinery - Safety related parts of control systems - Part 1: General principles for design
- EN 60204-1 Safety of machinery - Electrical equipment of machines - Part 1: General requirements
- EN 62061 Safety of machinery - Functional safety of safety-related electrical, electronic and programmable electronic control systems
- EN 61800-5-2 Adjustable speed electrical power drive systems - Part 5-2: Safety requirement - Functional
- IEC 61508 Part 1...7 Functional safety of electrical/electronic/programmable electronic safety-related systems

### EMC Directive (2004/108/EC and 2014/30/EU)

- EN 61800-3 - Adjustable speed electric power drive systems - Part 3: EMC requirements and specific test methods



# Rockwell Automation Support

Use the following resources to access support information.

<b>Technical Support Center</b>	Knowledgebase Articles, How-to Videos, FAQs, Chat, User Forums, and Product Notification Updates.	<a href="https://rockwellautomation.custhelp.com/">https://rockwellautomation.custhelp.com/</a>
<b>Local Technical Support Phone Numbers</b>	Locate the phone number for your country.	<a href="http://www.rockwellautomation.com/global/support/get-support-now.page">http://www.rockwellautomation.com/global/support/get-support-now.page</a>
<b>Direct Dial Codes</b>	Find the Direct Dial Code for your product. Use the code to route your call directly to a technical support engineer.	<a href="http://www.rockwellautomation.com/global/support/direct-dial.page">http://www.rockwellautomation.com/global/support/direct-dial.page</a>
<b>Literature Library</b>	Installation Instructions, Manuals, Brochures, and Technical Data.	<a href="http://www.rockwellautomation.com/global/literature-library/overview.page">http://www.rockwellautomation.com/global/literature-library/overview.page</a>
<b>Product Compatibility and Download Center (PCDC)</b>	Get help determining how products interact, check features and capabilities, and find associated firmware.	<a href="http://www.rockwellautomation.com/global/support/pcdc.page">http://www.rockwellautomation.com/global/support/pcdc.page</a>

## Documentation Feedback

Your comments will help us serve your documentation needs better. If you have any suggestions on how to improve this document, complete the How Are We Doing? form at

[http://literature.rockwellautomation.com/idc/groups/literature/documents/du/ra-du002\\_-en-e.pdf](http://literature.rockwellautomation.com/idc/groups/literature/documents/du/ra-du002_-en-e.pdf).

Rockwell Automation maintains current product environmental information on its website at <http://www.rockwellautomation.com/rockwellautomation/about-us/sustainability-ethics/product-environmental-compliance.page>.

Allen-Bradley, Connected Components Workbench, Guardmaster, Micro800, POINT Guard I/O, PowerFlex, Rockwell Automation, Rockwell Software, SensaGuard, and TotalFORCE are trademarks of Rockwell Automation, Inc.

Trademarks not belonging to Rockwell Automation are property of their respective companies.

Rockwell Otomasyon Ticaret A.Ş., Kar Plaza İş Merkezi E Blok Kat:6 34752 İçerenköy, İstanbul, Tel: +90 (216) 5698400

**[www.rockwellautomation.com](http://www.rockwellautomation.com)**

### Power, Control and Information Solutions Headquarters

Americas: Rockwell Automation, 1201 South Second Street, Milwaukee, WI 53204-2496 USA, Tel: (1) 414.382.2000, Fax: (1) 414.382.4444

Europe/Middle East/Africa: Rockwell Automation NV, Pegasus Park, De Kleetlaan 12a, 1831 Diegem, Belgium, Tel: (32) 2 663 0600, Fax: (32) 2 663 0640

Asia Pacific: Rockwell Automation, Level 14, Core F, Cyberport 3, 100 Cyberport Road, Hong Kong, Tel: (852) 2887 4788, Fax: (852) 2508 1846

Publication 750-UM002H-EN-P - February 2017

Supersedes Publication 750-RM001G-EN-P - February 2016

Copyright © 2017 Rockwell Automation, Inc. All rights reserved. Printed in the U.S.A.